



TRADITIONAL METAL DRYWALL FRAMING



TABLE OF CONTENTS

Code Compliance 2

Product Identification 3

General Product Information 4

Interior Non-Structural Section Properties - STUD(S) 5-6

Interior Non-Structural Section Properties - TRACK(T) 7-8

Interior Non-Structural Composite Wall Heights 9-10

Interior Non-Structural Non-Composite Wall Heights 11-12

Interior Non-Structural Braced 48" O.C. 13-14

Allowable Ceiling Spans - L/240 15-16

Allowable Ceiling Spans - L/360 17-18

Cold-Rolled Channel (CRC) Section Properties 19

Hat-Furring Channel (DWFC) 20-21

T-Brace Mechanical Bridging 22-23

T-Rule Technology 24

CODE COMPLIANCE

- **ICC ESR 2281**
- **AISI S100:** AISI's "North American Specification for the Design of Cold-formed Steel Structural Members"
- **ASTM International:**
 - **A653** - Standard Specification for Steel Sheet, Zinc-Coated (Galvanized) by the Hot-Dip Process.
 - **A1003** - Standard Specification for Steel Sheet, Carbon, and Metallic-Coated for Cold-Formed Framing Members.
 - **C645** - Standard Specification for Non-Structural Steel Framing Members
 - **C754** - Standard Specification for Installation of Steel Framing Members to Receive Screw-Attached Gypsum Panel Products.

Standard Knockout- Standard

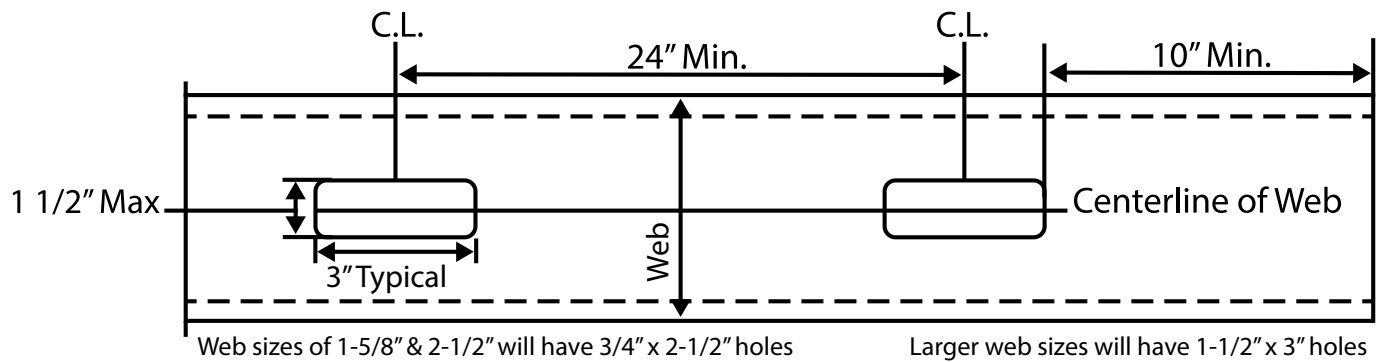

Oval Knockout - Available upon request

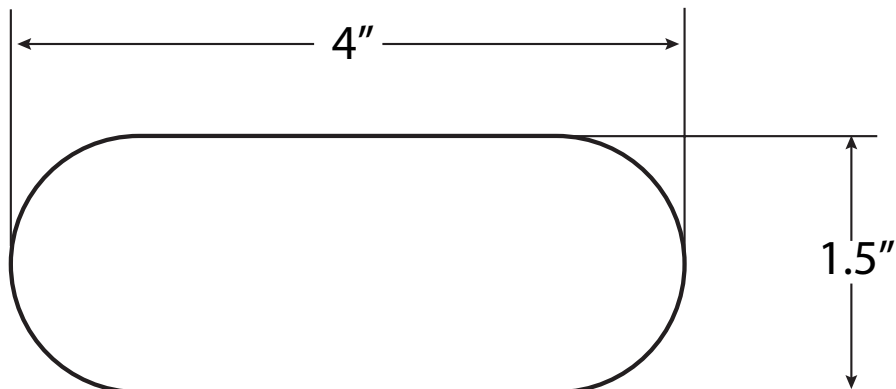

PRODUCT IDENTIFICATION

PRODUCT IDENTIFICATION - SECTION PROPERTIES

All Telling Industries products contain a four part identification code. This identifies the size (both depth and flange/leg height), style, and material thickness of each member.

MEMBER DEPTH:

(Example: 3-5/8" = 3.625" ~ 362 x 1/100 inches)
 All member depths are taken in 1/100 inches.
 For all "T" Sections, member depth is the inside to inside dimension.

MATERIAL THICKNESS:

(Example: 0.030 in = 30 mils; 1 mil = 1/1000 in.)
 Material thickness is the minimum base metal thickness in mils. Minimum base metal thickness represents 95% of the design thickness.

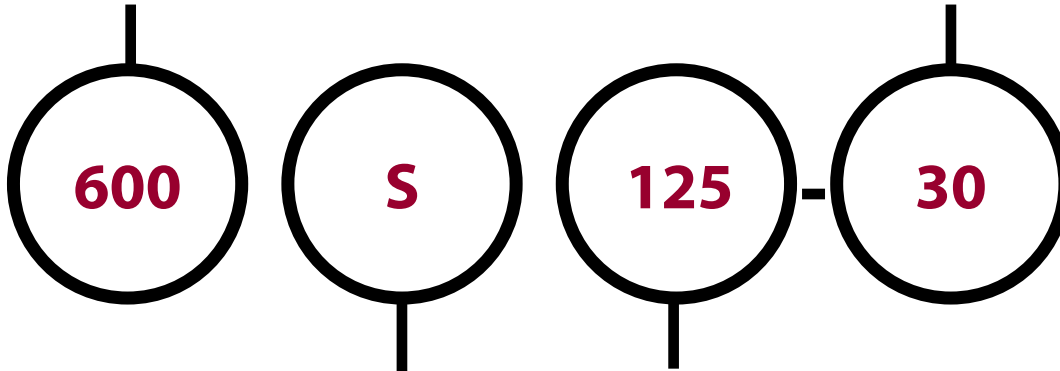

600

S

125

30

FLANGE WIDTH:

(Example: 1-1/4" = 1.25" ~ 125 x 1/100 inches)
 All flange widths are taken in 1/100 inches.

STYLE:

(Example: Stud or Joist section = S)

The five alpha characters utilized by the designator system are:

S = Stud or Joist Sections

T = Track Sections

CRC = Channel Sections

DWFC = Furring Channel Sections

TRADITIONAL INTERIOR FRAMING PROPERTIES & DATA

Thickness Nomenclature	Min Base Metal Thickness (in)	Design Thickness (in)	Min Yield Strength (ksi)	Standard Galvanization	Web Sizes (in)	Stud Flange / Leg Sizes (in)	Track Flange / Leg Sizes (in)	Design Inside Corner Radii (in)
18 mil	0.0179"	0.0188"	33 ksi	G40	1-5/8", 2.5", 3.5", 3-5/8", 4"	1-1/4"	1-1/4", 1.5"	0.0843"
27 mil	0.0269"	0.0283"	33 ksi	G40	1-5/8", 2.5", 3.5", 3-5/8", 4", 5.5", 6"	1-1/4"	1-1/4", 1.5"	0.0796"
30 mil	0.0296"	0.0312"	33 ksi	G40	1-5/8", 2.5", 3.5", 3-5/8", 4", 5.5", 6"	1-1/4"	1-1/4", 1.5"	0.0781"
33 mil	0.0329"	0.0346"	33 ksi	G40	1-5/8", 2.5", 3.5", 3-5/8", 4", 5.5", 6", 7-1/4", 8"	1-1/4", 1-3/8", 1-5/8", 2"	1-1/4", 1.5", 2"	0.0764"

Return lip is 0.1875" for all traditional interior framing studs.

G60 & G90 available for an upcharge.

Drywall max Web 6" 33mil structural max web is 8".

Drywall max Leg 1-1/4". 33mil structural max Leg is 2". 1-5/8" web has max 2" leg on press brake.

Drywall max Leg 1-1/4". 33mil Structural max Leg is 2". 1.5" is Press Brake only.

GENERAL PRODUCT INFORMATION

RAW MATERIAL INFORMATION

All Telling Industries products are formed from steel with a minimum yield strength of 33 or 50 KSI (1000 lbs. per square inch). All products contained in this brochure are engineered to meet the 2012 Edition of the AISI (American Iron and Steel Institute) North American Specification for the Design of Cold-Formed Steel Structural Members. The same document was used to calculate the physical and structural properties of all products listed herein via allowable stress design criteria.

TECHNICAL ASSISTANCE

Technical assistance is available to Telling Industries customers when requested. A Telling

Industries representative or design professional can review project specific load conditions and determine deflection criteria and lateral bracing conditions not discussed herein. Further, our representatives can assist purchasers and designers in economic applications for maximum efficiency.

All information contained in this brochure is intended as a general guide for using Telling Industries' products. This information should not be used in design or assembly without an independent assessment by a qualified design professional. Such an assessment is necessary to verify the suitability of a particular product for use in

any load bearing application. Telling Industries assume no liability for failure resulting from the use or misapplications of any information contained herein. Detail drawings contained herein are for information only. Telling Industries reserve the right to make modifications, changes, additions or deletions to the information on any of our products without prior notice or obligation. For the latest product information or to verify availability, contact a Telling Industries representative. This brochure contains the latest information available at the time of printing.

GENERAL NOTES FOR ALL TABLES

1. Where AISI S100-12 is referenced, it is the "North American Specification for the Design of Cold-Formed Steel Structural Members", 2012 Edition, with US provisions.
2. The strength increase from cold work of forming has been incorporated for flexural strength per Section A7.2 of AISI S100-12.
3. The effective moment of inertia for deflection is calculated at a stress which results in a section modulus such that the stress times the section modulus at that stress is equal to the allowable moment. AISI S100-12 Specification Procedure 1 for serviceability determination has been used. Increases in the effective moment of inertia (I_{xe}) may be possible at lower stress levels. Any modified values would be required to be calculated by a qualified engineer.
4. Various sections may be manufactured with yield points of 33 or 50 ksi. The yield point used for calculations are listed in the tables.
5. For sections available in both 33 and 50 ksi, the specifier must be clearly indicate which yield point is required. For example: 362S162-68 (50ksi).
6. When provided, factory punch-outs will be located along the centerline of the webs of the members and will have a minimum center-to-center spacing of 24 inches. Punch-outs for members greater than 2.5 inches deep are a maximum of 1.5 inches wide x 4 inches long. Members with depths 2.5 inches and smaller are maximum of 3/4 inches wide x 4 inches long.

INTERIOR NON-STRUCTURAL, NON-COMPOSITE WALL HEIGHT TABLES NOTES

1. Lateral loads have not been modified for deflection checks.
2. For lateral pressures ≤ 10 psf, safety factors have been based on 0.9Ω per AISI S220-11, B1(a). For 15 psf, Ω has not been modified.
3. Flexural strength taken as the minimum of local buckling and distortional buckling allowable moments, adjusted as indicated in Note 2.
4. For distortional buckling allowable moment, $k_f = 0$.
5. Limiting non-composite heights noted as "FULLY BRACED" based on continuous support of each flange over the full length of the stud.
6. Limiting non-composite heights noted as "BRACED AT 48" o.c." based on properly attached bridging or blocking at a maximum 48" oc spacing.
7. Moment of inertia for deflection is calculated at the maximum service level stress for the height listed. Note that this value may be higher than the effective I_{xx} listed in section property tables.
8. Limiting non-composite heights are based on steel properties only.
9. Web crippling check based on 1 inch end bearing. Where listed limiting heights are followed by "e", web stiffeners are required.
10. Shear and web crippling capacity have not been reduced for punch-outs.

GROSS PROPERTIES

- I_{xx}**: Moment of inertia of gross section about the X-X axis (strong axis).
R_x: Radius of gyration of the gross section about the X-X axis.

I_{yy}: Moment of inertia of gross section about the Y-Y axis (weak axis).

R_y: Radius of gyration of the gross section about the Y-Y axis.

EFFECTIVE PROPERTIES

I_{xx}: Effective moment of inertia about the X-axis.

S_{xx}: Effective section modulus about the X-X axis (strong axis) stress = F_y .

Ma-L: Allowable Bending Moment - Based on the effective section modulus and the allowable stress including the strength increase from the cold-work of forming (Section A7.2) where applicable.

Ma-D: Allowable Bending Moment - Based on Distortional Bucking Strength calculated per AISI section C3.1.4

Vag: Allowable strong axis shear away from punch-out, calculated in accordance with AISI Section C3.2.1.

VaNet: Allowable strong axis shear at punch-out, calculated in accordance with AISI Section C3.2.2.

TORSIONAL AND OTHER PROPERTIES

Jx1000: St. Venant Torsional Constant.

Cw: Torsional warping constant.

m: Distance from shear center to mid-plane of web.

Xo: Distance from the shear center to the centroid along the principal X-axis.

Ro: Polar radius of gyration about the centroidal principal axis.

b: $1-(X_o/R_o)^2$

Lu: The longest weak axis (L_y) and torsional (L_t) unbraced length at which lateral torsional buckling is restrained in accordance with AISI C3.1.2.1.



INTERIOR NON-STRUCTURAL SECTION PROPERTIES - STUD (S)

Section	Gross Properties						33 ksi Effective Properties					Torsional Properties				
	Area	Weight	Ixx (in ⁴)	Rx (in)	Iyy (in ⁴)	Ry (in)	Ixx (in ⁴)	Sxx (in ³)	Ma (in-k)	Va (lb)	Ycg (in)	Jx1000 (in ⁴)	Cw (in ⁶)	Xo (in)	Ro (in)	β
162S125-18	0.08	0.27	0.038	0.686	0.016	0.447	0.034	0.031	0.61	302	0.962	0.009	0.009	-1.029	1.315	0.388
162S125-27	0.12	0.41	0.056	0.682	0.023	0.443	0.055	0.053	1.05	494	0.903	0.032	0.013	-1.017	1.302	0.39
162S125-30	0.131	0.45	0.061	0.681	0.026	0.441	0.06	0.06	1.19	543	0.889	0.043	0.014	-1.014	1.298	0.39
162S125-33	0.145	0.49	0.067	0.679	0.028	0.44	0.066	0.069	1.37	601	0.873	0.058	0.016	-1.01	1.294	0.391
250S125-18	0.097	0.33	0.099	1.014	0.019	0.439	0.089	0.059	1.17	258	1.391	0.011	0.023	-0.904	1.427	0.599
250S125-27	0.144	0.49	0.147	1.009	0.027	0.434	0.144	0.097	1.92	685	1.343	0.039	0.034	-0.893	1.416	0.602
250S125-30	0.159	0.54	0.161	1.008	0.03	0.433	0.159	0.11	2.17	832	1.329	0.052	0.037	-0.889	1.412	0.603
250S125-33	0.176	0.6	0.178	1.006	0.033	0.431	0.175	0.125	2.48	975	1.313	0.07	0.04	-0.885	1.408	0.605
250S137-33	0.197	0.67	0.203	1.015	0.052	0.515	0.203	0.158	3.11	975	1.268	0.079	0.076	-1.141	1.612	0.499
250S162-33	0.223	0.76	0.235	1.027	0.087	0.624	0.235	0.18	3.55	975	1.274	0.089	0.146	-1.47	1.898	0.401
250S200-33	0.258	0.88	0.279	1.04	0.154	0.773	0.276	0.197	3.9	975	1.312	0.103	0.302	-1.926	2.321	0.312
350S125-18	0.115	0.39	0.215	1.366	0.021	0.423	0.203	0.072	1.42	180	2.175	0.014	0.05	-0.797	1.637	0.763
350S125-27	0.173	0.59	0.32	1.361	0.03	0.418	0.315	0.13	2.57	614	2.02	0.046	0.072	-0.787	1.627	0.766
350S125-30	0.19	0.65	0.351	1.359	0.033	0.417	0.346	0.15	2.96	824	1.979	0.062	0.079	-0.784	1.624	0.767
350S125-33	0.21	0.72	0.387	1.358	0.036	0.415	0.382	0.175	3.45	1024	1.935	0.084	0.087	-0.78	1.62	0.768
350S137-33	0.232	0.79	0.441	1.38	0.059	0.503	0.441	0.223	4.41	1024	1.848	0.093	0.153	-1.016	1.786	0.676
350S162-33	0.258	0.88	0.508	1.404	0.098	0.617	0.508	0.257	5.08	1024	1.845	0.103	0.277	-1.324	2.026	0.573
350S200-33	0.292	0.99	0.598	1.431	0.175	0.773	0.597	0.283	5.59	1024	1.899	0.117	0.541	-1.76	2.396	0.461
362S125-18	0.118	0.4	0.234	1.409	0.021	0.421	0.221	0.075	1.48	173	2.262	0.014	0.054	-0.786	1.667	0.778
362S125-27	0.176	0.6	0.347	1.404	0.031	0.416	0.342	0.135	2.67	592	2.102	0.047	0.079	-0.776	1.657	0.781
362S125-30	0.194	0.66	0.381	1.402	0.033	0.415	0.376	0.156	3.08	794	2.059	0.063	0.086	-0.773	1.654	0.782
362S125-33	0.215	0.73	0.421	1.4	0.037	0.413	0.415	0.182	3.59	1024	2.013	0.086	0.094	-0.769	1.65	0.783
362S137-33	0.236	0.8	0.479	1.424	0.059	0.501	0.479	0.232	4.59	1024	1.923	0.094	0.165	-1.003	1.813	0.694
362S162-33	0.262	0.89	0.551	1.45	0.099	0.616	0.551	0.268	5.29	1024	1.919	0.105	0.297	-1.308	2.048	0.592
362S200-33	0.297	1.01	0.648	1.478	0.177	0.772	0.647	0.294	5.81	1024	1.974	0.118	0.577	-1.741	2.411	0.478
400S125-184	0.125	0.42	0.294	1.536	0.021	0.414	0.281	0.083	1.64	156	2.524	0.015	0.068	-0.754	1.76	0.816
400S125-27	0.187	0.64	0.438	1.531	0.031	0.41	0.431	0.151	2.97	533	2.349	0.05	0.098	-0.744	1.751	0.819
400S125-30	0.206	0.7	0.481	1.529	0.034	0.408	0.474	0.174	3.44	715	2.303	0.067	0.107	-0.741	1.748	0.82
400S125-33	0.228	0.77	0.531	1.527	0.038	0.407	0.524	0.203	4.01	976	2.252	0.091	0.118	-0.738	1.744	0.821
400S137-33	0.249	0.85	0.603	1.556	0.061	0.496	0.603	0.259	5.12	976	2.152	0.099	0.204	-0.965	1.897	0.741
400S162-33	0.275	0.94	0.692	1.586	0.103	0.611	0.692	0.299	5.91	976	2.144	0.11	0.363	-1.263	2.118	0.644
400S200-33	0.31	1.05	0.812	1.619	0.183	0.769	0.812	0.328	6.49	976	2.2	0.124	0.697	-1.688	2.462	0.53

Notes:

For SI: 1 inch = 25.4mm, 1 pound = 4.4482 N.

- Gross properties and torsional properties are based on the full-unreduced cross section of the studs, away from web punch-outs.
- Effective properties are based on punched sections.
- Use the effective moment of inertia for deflection calculations.
- Web height to thickness ratio, h/t, exceeds 200. Web must have bearing stiffeners in accordance with AISI S100. No holes or punch-outs are permitted in the web.

SYMBOLS:**Ixx** = Strong axis moment of inertia.**Rx** = Strong axis radius of gyration.**Iyy** = Weak axis moment of inertia.**Ry** = Weak axis radius of gyration.**Sxx** = Strong axis section modulus.**Va** = Allowable shear at unpunched web section.

INTERIOR NON-STRUCTURAL SECTION PROPERTIES - STUD (S)

Section	Gross Properties						33 ksi Effective Properties					Torsional Properties				
	Area	Weight	I _{xx} (in ⁴)	R _x (in)	I _{yy} (in ⁴)	R _y (in)	I _{xx} (in ⁴)	S _{xx} (in ³)	Ma (in-k)	Va (lb)	Y _{cg} (in)	J _{x1000} (in ⁴)	C _w (in ⁶)	X _o (in)	R _o (in)	β
550S125-27	0.229	0.78	0.938	2.023	0.034	0.385	0.898	0.246	4.86	382	3.15	0.061	0.205	-0.641	2.157	0.912
550S125-30	0.252	0.86	1.031	2.021	0.037	0.384	0.996	0.286	5.65	512	3.083	0.082	0.224	-0.639	2.154	0.912
550S125-33	0.279	0.95	1.139	2.019	0.041	0.382	1.111	0.335	6.62	699	3.012	0.112	0.246	-0.635	2.151	0.913
550S137-33	0.301	1.02	1.283	2.064	0.067	0.472	1.283	0.453	8.95	699	2.781	0.12	0.411	-0.841	2.278	0.864
550S162-33	0.327	1.11	1.458	2.112	0.113	0.589	1.458	0.512	10.11	699	2.787	0.13	0.713	-1.114	2.459	0.795
550S200-33	0.362	1.23	1.694	2.164	0.204	0.751	1.678	0.559	11.05	699	2.851	0.144	1.326	-1.508	2.742	0.698
600S125-27 ⁴	0.243	0.83	1.16	2.183	0.035	0.377	1.097	0.271	5.35	349	3.479	0.065	0.251	-0.614	2.299	0.929
600S125-30	0.268	0.91	1.275	2.181	0.038	0.376	1.218	0.315	6.22	468	3.405	0.087	0.274	-0.611	2.296	0.929
600S125-33	0.297	1.01	1.409	2.179	0.042	0.374	1.361	0.369	7.3	638	3.326	0.118	0.3	-0.608	2.293	0.93
600S137-33	0.318	1.08	1.582	2.229	0.069	0.464	1.548	0.455	8.98	638	3.224	0.127	0.5	-0.807	2.416	0.889
600S162-33	0.344	1.17	1.793	2.282	0.116	0.581	1.793	0.577	11.41	638	3.039	0.137	0.861	-1.072	2.587	0.828
600S200-33	0.379	1.29	2.075	2.34	0.209	0.743	2.058	0.621	12.28	638	3.126	0.151	1.593	-1.457	2.855	0.74
725S125-27 ⁴	0.279	0.95	1.852	2.577	0.036	0.36	1.693	0.332	6.56	287	4.324	0.074	0.387	-0.554	2.661	0.957
725S125-30 ⁴	0.307	1.04	2.036	2.575	0.039	0.358	1.886	0.387	7.65	384	4.235	0.1	0.423	-0.552	2.658	0.957
725S125-33 ⁴	0.34	1.16	2.251	2.573	0.043	0.357	2.114	0.456	9	525	4.137	0.136	0.464	-0.549	2.655	0.957
725S137-33 ⁴	0.362	1.23	2.509	2.634	0.072	0.445	2.392	0.559	11.05	525	4.009	0.144	0.766	-0.733	2.77	0.93
725S162-33 ⁴	0.388	1.32	2.822	2.698	0.122	0.562	2.706	0.638	12.61	525	3.986	0.155	1.309	-0.982	2.926	0.887
725S200-33 ⁴	0.422	1.44	3.241	2.771	0.221	0.724	3.234	0.743	14.67	525	3.915	0.168	2.395	-1.346	3.164	0.819
800S125-30 ⁴	0.33	1.12	2.606	2.808	0.04	0.349	2.366	0.43	8.5	347	4.746	0.107	0.531	-0.522	2.878	0.967
800S125-33 ¹	0.366	1.25	2.881	2.806	0.044	0.347	2.656	0.507	10.02	474	4.639	0.146	0.582	-0.519	2.875	0.967
800S137-33 ⁴	0.388	1.32	3.198	2.873	0.073	0.435	2.998	0.622	12.3	474	4.495	0.155	0.957	-0.696	2.987	0.946
800S162-33 ⁴	0.413	1.41	3.582	2.943	0.125	0.55	3.384	0.71	14.03	474	4.464	0.165	1.63	-0.936	3.137	0.911
800S200-33 ⁴	0.448	1.52	4.096	3.023	0.227	0.712	4.096	0.816	16.12	474	4.402	0.179	2.971	-1.288	3.363	0.853

Notes:

For SI: 1 inch = 25.4mm, 1 pound = 4.4482 N.

- Gross properties and torsional properties are based on the full-unreduced cross section of the studs, away from web punch-outs.
- Effective properties are based on punched sections.
- Use the effective moment of inertia for deflection calculations.
- Web height to thickness ratio, h/t, exceeds 200. Web must have bearing stiffeners in accordance with AISI S100. No holes or punch-outs are permitted in the web.

SYMBOLS:

- I_{xx} = Strong axis moment of inertia.
 R_x = Strong axis radius of gyration.
 I_{yy} = Weak axis moment of inertia.
 R_y = Weak axis radius of gyration.
 S_{xx} = Strong axis section modulus.
 V_a = Allowable shear at unpunched web section.



INTERIOR NON-STRUCTURAL SECTION PROPERTIES - TRACK (T)

Section	Gross Properties ¹						33 ksi Effective Properties ²					Torsional Properties				
	Area	Weight	Ixx (in ⁴)	Rx (in)	Iyy (in ⁴)	Ry (in)	Ixx (in ⁴)	Sxx (in ³)	Ma (in-k)	Va (lb)	Ycg (in)	Jx1000 (in ⁴)	Cw (in ⁶)	Xo (in)	Ro (in)	β
162T125-18	0.077	0.26	0.041	0.733	0.013	0.411	0.03	0.025	0.5	302	1.082	0.009	0.007	-0.878	1.215	0.478
162T125-27	0.117	0.4	0.063	0.735	0.02	0.41	0.05	0.044	0.87	541	1.048	0.031	0.01	-0.872	1.211	0.482
162T125-30	0.129	0.44	0.07	0.735	0.022	0.409	0.057	0.05	1	597	1.038	0.042	0.012	-0.87	1.21	0.483
162T125-33	0.143	0.49	0.077	0.736	0.024	0.408	0.066	0.058	1.15	663	1.026	0.057	0.013	-0.868	1.209	0.484
162T150-27	0.131	0.45	0.074	0.75	0.032	0.495	0.055	0.045	0.9	541	1.092	0.035	0.017	-1.1	1.42	0.4
162T150-30	0.144	0.49	0.081	0.751	0.035	0.494	0.062	0.052	1.03	597	1.082	0.047	0.019	-1.098	1.419	0.401
162T150-33	0.16	0.54	0.09	0.751	0.039	0.494	0.072	0.06	1.19	663	1.07	0.064	0.021	-1.096	1.418	0.402
162T200-33	0.194	0.66	0.116	0.773	0.085	0.66	0.081	0.063	1.25	663	1.145	0.078	0.047	-1.565	1.866	0.297
250T125-18	0.094	0.32	0.103	1.051	0.015	0.4	0.078	0.045	0.9	249	1.58	0.011	0.018	-0.769	1.362	0.681
250T125-27	0.141	0.48	0.157	1.053	0.022	0.398	0.129	0.079	1.56	685	1.519	0.038	0.027	-0.763	1.36	0.685
250T125-30	0.156	0.53	0.173	1.053	0.025	0.397	0.145	0.09	1.77	832	1.507	0.051	0.03	-0.762	1.359	0.686
250T125-33	0.173	0.59	0.192	1.054	0.027	0.397	0.166	0.103	2.03	1024	1.492	0.069	0.033	-0.76	1.358	0.687
250T150-27	0.156	0.53	0.181	1.078	0.037	0.486	0.139	0.082	1.61	685	1.576	0.042	0.044	-0.976	1.534	0.595
250T150-30	0.172	0.58	0.199	1.078	0.04	0.486	0.157	0.093	1.83	832	1.563	0.056	0.049	-0.975	1.533	0.595
250T150-33	0.19	0.65	0.221	1.079	0.045	0.485	0.179	0.107	2.11	1024	1.548	0.076	0.054	-0.973	1.532	0.596
250T200-33	0.225	0.76	0.28	1.117	0.097	0.658	0.203	0.112	2.22	1024	1.647	0.09	0.118	-1.418	1.921	0.455
350T125-18	0.113	0.38	0.219	1.394	0.016	0.383	0.174	0.063	1.25	175	2.264	0.013	0.038	-0.675	1.595	0.821
350T125-27	0.17	0.58	0.331	1.396	0.025	0.381	0.277	0.128	2.53	590	2.044	0.045	0.057	-0.67	1.595	0.823
350T125-30	0.187	0.64	0.365	1.396	0.027	0.38	0.312	0.145	2.86	790	2.03	0.061	0.063	-0.669	1.594	0.824
350T125-33	0.207	0.71	0.405	1.397	0.03	0.379	0.354	0.165	3.27	1024	2.014	0.083	0.07	-0.668	1.594	0.824
350T150-27	0.184	0.63	0.377	1.431	0.041	0.47	0.298	0.132	2.62	590	2.111	0.049	0.094	-0.869	1.739	0.75
350T150-30	0.203	0.69	0.416	1.432	0.045	0.469	0.336	0.15	2.96	790	2.097	0.066	0.103	-0.867	1.739	0.751
350T150-33	0.225	0.76	0.461	1.432	0.049	0.469	0.382	0.171	3.39	1024	2.08	0.09	0.114	-0.866	1.738	0.752
350T200-33	0.259	0.88	0.574	1.487	0.108	0.647	0.428	0.181	3.57	1024	2.199	0.103	0.249	-1.285	2.069	0.614
362T125-18	0.115	0.39	0.237	1.435	0.017	0.38	0.189	0.065	1.29	169	2.352	0.014	0.042	-0.665	1.627	
362T125-27	0.173	0.59	0.358	1.438	0.025	0.378	0.301	0.135	2.66	569	2.109	0.046	0.062	-0.661	1.627	
362T125-30	0.191	0.65	0.395	1.438	0.027	0.378	0.339	0.152	3.01	762	2.095	0.062	0.068	-0.659	1.626	
362T125-33	0.212	0.72	0.438	1.438	0.03	0.377	0.384	0.174	3.44	1024	2.079	0.085	0.076	-0.658	1.626	
362T150-27	0.187	0.64	0.408	1.475	0.041	0.468	0.323	0.14	2.76	569	2.177	0.05	0.102	-0.857	1.769	
362T150-30	0.207	0.7	0.449	1.475	0.045	0.467	0.364	0.158	3.12	762	2.162	0.067	0.112	-0.856	1.768	
362T150-33	0.229	0.78	0.499	1.475	0.05	0.467	0.414	0.18	3.56	1024	2.146	0.091	0.124	-0.854	1.767	
362T200-33	0.264	0.9	0.619	1.532	0.11	0.645	0.464	0.19	3.76	1024	2.267	0.105	0.269	-1.27	2.092	

Notes:

For SI: 1 inch = 25.4mm, 1 pound = 4.4482 N.

- Gross properties and torsional properties are based on the full-unreduced cross section of the studs, away from web punch-outs.
- Effective properties are based on punched sections.
- Use the effective moment of inertia for deflection calculations.
- Web height to thickness ratio, h/t, exceeds 200. Web must have bearing stiffeners in accordance with AISI S100. No holes or punch-outs are permitted in the web.

SYMBOLS:

- Ixx = Strong axis moment of inertia.
 Rx = Strong axis radius of gyration.
 Iyy = Weak axis moment of inertia.
 Ry = Weak axis radius of gyration.
 Sxx = Strong axis section modulus.
 Va = Allowable shear at unpunched web section.

INTERIOR NON-STRUCTURAL SECTION PROPERTIES - TRACK (T)

Section	Gross Properties ¹						33 ksi Effective Properties ²					Torsional Properties				
	Area	Weight	I _{xx} (in ⁴)	R _x (in)	I _{yy} (in ⁴)	R _y (in)	I _{xx} (in ⁴)	S _{xx} (in ³)	Ma (in-k)	Va (lb)	Y _{cg} (in)	J _{x1000} (in ⁴)	C _w (in ⁶)	X _o (in)	R _o (in)	β
400T125-18 ³	0.122	0.41	0.297	1.56	0.017	0.374	0.241	0.072	1.42	153	2.619	0.014	0.052	-0.637	1.726	
400T125-27	0.184	0.63	0.449	1.562	0.025	0.372	0.38	0.156	3.08	515	2.306	0.049	0.078	-0.633	1.726	
400T125-30	0.203	0.69	0.495	1.562	0.028	0.371	0.427	0.176	3.49	689	2.289	0.066	0.085	-0.632	1.726	
400T125-33	0.225	0.76	0.549	1.563	0.031	0.371	0.484	0.201	3.97	940	2.272	0.09	0.095	-0.63	1.725	
400T150-27	0.198	0.67	0.509	1.602	0.042	0.461	0.409	0.154	3.04	515	2.42	0.053	0.127	-0.824	1.86	
400T150-30	0.218	0.74	0.561	1.603	0.046	0.461	0.458	0.183	3.61	689	2.359	0.071	0.14	-0.823	1.859	
400T150-33	0.242	0.82	0.622	1.603	0.051	0.46	0.519	0.208	4.12	940	2.342	0.097	0.155	-0.821	1.859	
400T200-33	0.277	0.94	0.768	1.666	0.113	0.639	0.581	0.22	4.34	940	2.469	0.11	0.336	-1.229	2.166	
550T125-27	0.226	0.77	0.948	2.046	0.027	0.348	0.786	0.192	3.79	372	3.464	0.06	0.16	-0.543	2.145	
550T125-30	0.25	0.85	1.045	2.046	0.03	0.347	0.897	0.226	4.47	499	3.385	0.081	0.176	-0.542	2.145	
550T125-33	0.277	0.94	1.159	2.046	0.033	0.346	1.029	0.27	5.33	680	3.302	0.11	0.195	-0.541	2.145	
550T150-27	0.241	0.82	1.059	2.098	0.046	0.436	0.893	0.207	4.1	372	3.46	0.064	0.263	-0.716	2.259	
550T150-30	0.265	0.9	1.168	2.098	0.05	0.435	0.995	0.251	4.96	499	3.349	0.086	0.289	-0.715	2.259	
550T150-33	0.294	1	1.295	2.099	0.055	0.434	1.115	0.31	6.12	680	3.224	0.117	0.32	-0.714	2.259	
550T200-33	0.329	1.12	1.567	2.184	0.123	0.613	1.246	0.307	6.06	680	3.453	0.131	0.694	-1.088	2.516	0.813
600T125-27 ³	0.241	0.82	1.168	2.204	0.028	0.34	0.958	0.21	4.16	341	3.812	0.064	0.196	-0.519	2.29	0.949
600T125-30	0.265	0.9	1.288	2.204	0.031	0.34	1.095	0.249	4.92	456	3.726	0.086	0.215	-0.518	2.289	0.949
600T125-33	0.294	1	1.428	2.204	0.034	0.339	1.258	0.297	5.87	622	3.635	0.117	0.238	-0.516	2.289	0.949
600T150-27 ³	0.255	0.87	1.3	2.26	0.047	0.427	1.011	0.214	4.23	341	3.919	0.068	0.32	-0.686	2.4	0.918
600T150-30	0.281	0.96	1.434	2.26	0.051	0.427	1.159	0.253	5.01	456	3.831	0.091	0.352	-0.685	2.4	0.918
600T150-33	0.311	1.06	1.59	2.26	0.057	0.426	1.334	0.303	5.99	622	3.737	0.124	0.39	-0.684	2.399	0.919
600T200-33	0.346	1.18	1.913	2.352	0.126	0.604	1.542	0.333	6.59	622	3.803	0.138	0.847	-1.048	2.645	0.843
725T125-27 ³	0.276	0.94	1.855	2.593	0.029	0.323	1.471	0.258	5.09	281	4.703	0.074	0.301	-0.467	2.654	0.969
725T125-30 ³	0.304	1.03	2.045	2.593	0.032	0.323	1.688	0.306	6.04	377	4.599	0.099	0.33	-0.466	2.654	0.969
725T125-33 ³	0.337	1.15	2.268	2.593	0.035	0.322	1.946	0.365	7.22	514	4.489	0.135	0.365	-0.465	2.654	0.969
725T150-27 ³	0.29	0.99	2.047	2.656	0.048	0.409	1.546	0.262	5.17	281	4.818	0.077	0.493	-0.623	2.759	0.949
725T150-30 ³	0.32	1.09	2.256	2.656	0.053	0.408	1.776	0.311	6.14	377	4.713	0.104	0.543	-0.622	2.759	0.949
725T150-33 ³	0.355	1.21	2.502	2.657	0.059	0.407	2.053	0.372	7.36	514	4.6	0.141	0.601	-0.62	2.758	0.949
725T200-33 ³	0.389	1.32	2.971	2.763	0.132	0.583	2.465	0.4	7.91	514	4.698	0.155	1.307	-0.962	2.983	0.896
800T125-30 ³	0.328	1.11	2.611	2.824	0.032	0.314	2.113	0.339	6.71	341	5.136	0.106	0.413	-0.44	2.875	0.977
800T125-33 ³	0.363	1.24	2.895	2.824	0.036	0.313	2.441	0.407	8.03	465	5.015	0.145	0.456	-0.439	2.875	0.977
800T150-30 ¹	0.343	1.17	2.868	2.891	0.054	0.398	2.219	0.345	6.82	341	5.254	0.111	0.679	-0.589	2.977	0.961
800T150-33 ³	0.38	1.29	3.18	2.891	0.06	0.397	2.569	0.414	8.18	465	5.131	0.152	0.751	-0.588	2.977	0.961
800T200-33 ³	0.415	1.41	3.749	3.005	0.135	0.571	2.788	0.424	8.37	465	5.349	0.166	1.638	-0.917	3.194	0.918

For SI: 1 inch = 25.4mm, 1 pound = 4.4482 N.

- Gross properties and torsional properties are based on the full-unreduced cross section of the studs, away from web punch-outs.
- Effective properties are based on punched sections.
- Use the effective moment of inertia for deflection calculations.
- Web height to thickness ratio, h/t, exceeds 200. Web must have bearing stiffeners in accordance with AISI S100. No holes or punch-outs are permitted in the web.

I_{xx} = Strong axis moment of inertia.

R_x = Strong axis radius of gyration.

I_{yy} = Weak axis moment of inertia.

R_y = Weak axis radius of gyration.

S_{xx} = Strong axis section modulus.

Va = Allowable shear at unpunched web section.



INTERIOR NON-STRUCTURAL COMPOSITE WALL HEIGHTS

Section	Spacing (in, o.c.)	Fy (ksi)	5 psf			7.5 psf			10 psf			15 psf		
			L/120	L/240	L/360	L/120	L/240	L/360	L/120	L/240	L/360	L/120	L/240	L/360
162S125-27	12"	33	14'-9"	11'-8"	10'-2"	12'-10"	10'-2"	8'-7"	11'-8"	9'-1"	7'-6"	---	---	---
	16"		13'-4"	10'-7"	9'-1"	11'-8"	9'-1"	7'-6"	10'-7"	7'-11"	---	---	---	---
	24"		11'-8"	9'-1"	---	10'-2"	---	---	9'-1"	---	---	---	---	---
162S125-30	12"	33	14'-11"	11'-10"	10'-4"	13'-1"	10'-4"	8'-11"	11'-10"	9'-4"	7'-11"	9'-10"	7'-11"	---
	16"		13'-7"	10'-9"	9'-4"	11'-10"	9'-4"	7'-11"	10'-9"	8'-3"	---	8'-6"	---	---
	24"		11'-10"	9'-4"	7'-11"	10'-4"	7'-11"	---	9'-4"	---	---	---	---	---
250S125-27	12"	33	18'-7"	15'-4"	13'-9"	16'-3"	13'-5"	12'-0"	14'-9"	12'-2"	10'-11"	---	---	---
	16"		16'-10"	13'-11"	12'-5"	14'-9"	12'-2"	10'-11"	13'-5"	11'-1"	9'-11"	---	---	---
	24"		14'-9"	12'-2"	10'-11"	12'-11"	10'-8"	9'-4"	11'-3" f	9'-8"	8'-1"	---	---	---
250S125-30	12"	33	18'-5"	15'-10"	14'-1"	16'-1"	13'-10"	12'-4"	14'-7"	12'-7"	11'-2"	11'-0"	11'-0" f	9'-9"
	16"		16'-9"	14'-5"	12'-10"	14'-7"	12'-7"	11'-2"	13'-3"	11'-5"	10'-2"	9'-6"	9'-6" f	8'-8"
	24"		14'-7"	12'-7"	11'-2"	12'-9"	11'-0"	9'-9"	11'-7"	10'-0"	8'-8"	7'-9"	7'-9" f	---
250S125-33	12"	33	19'-8"	15'-8"	13'-8"	17'-3"	13'-8"	11'-11"	15'-8"	12'-5"	10'-10"	11'-5"	10'-10"	9'-5"
	16"		17'-11"	14'-3"	12'-5"	15'-8"	12'-5"	10'-10"	14'-3"	11'-3"	9'-10"	9'-11"	9'-10"	8'-4"
	24"		15'-8"	12'-5"	10'-10"	13'-8"	10'-10"	9'-5"	12'-4" f	9'-10"	8'-4"	8'-1"	8'-1" f	---
350S125-18	12"	33	18'-3" f	16'-4"	14'-4"	14'-11" f	14'-4"	12'-6"	12'-11" f	12'-11" f	11'-4"	8'-5"	8'-5" f	8'-5" f
	16"		15'-10" f	14'-10"	13'-0"	12'-11" f	12'-11" f	11'-4"	11'-2" f	11'-2" f	10'-3"	---	---	---
	24"		12'-11" f	12'-11" f	11'-4"	10'-7" f	10'-7" f	9'-11"	9'-2" f	9'-2" f	9'-0"	---	---	---
350S125-27	12"	33	22'-6"	17'-11"	15'-7"	19'-8"	15'-7"	13'-8"	17'-11"	14'-2"	12'-4"	12'-0"	12'-0" f	10'-8"
	16"		20'-6"	16'-3"	14'-2"	17'-11"	14'-2"	12'-4"	15'-10" f	12'-11"	11'-2"	10'-5"	10'-5" f	---
	24"		17'-11"	14'-2"	12'-4"	14'-11" f	12'-4"	10'-8"	12'-11" f	11'-2"	---	---	---	---
350S125-30	12"	33	22'-6"	17'-11"	15'-8"	19'-8"	15'-8"	13'-8"	17'-11"	14'-2"	12'-4"	12'-10"	12'-4"	10'-7"
	16"		20'-6"	16'-3"	14'-2"	17'-11"	14'-2"	12'-4"	16'-3"	12'-11"	11'-1"	11'-1"	11'-1" f	---
	24"		17'-11"	14'-2"	12'-4"	15'-8"	12'-4"	10'-7"	13'-9" f	11'-1"	---	---	---	---
350S125-33	12"	33	23'-0"	18'-3"	15'-11"	20'-1"	15'-11"	13'-11"	18'-3"	14'-6"	12'-8"	13'-3"	12'-8"	10'-10"
	16"		20'-11"	16'-7"	14'-6"	18'-3"	14'-6"	12'-8"	16'-7"	13'-2"	11'-4"	11'-6"	11'-4"	9'-8"
	24"		18'-3"	14'-6"	12'-8"	15'-11"	12'-8"	10'-10"	14'-4" f	11'-4"	9'-8"	---	---	---
362S125-18	12"	33	18'-8" f	16'-8"	14'-7"	15'-3" f	14'-7"	12'-9"	13'-2" f	13'-2" f	11'-6"	8'-8"	8'-8" f	8'-8" f
	16"		16'-2" f	15'-2"	13'-3"	13'-2" f	13'-2" f	11'-6"	11'-5" f	11'-5" f	10'-4"	---	---	---
	24"		13'-2" f	13'-2" f	11'-6"	10'-9" f	10'-9" f	9'-11"	9'-4" f	9'-4" f	8'-11"	---	---	---
362S125-27	12"	33	22'-10"	18'-2"	15'-10"	19'-11"	15'-10"	13'-10"	18'-2"	14'-5"	12'-6"	12'-0"	12'-0" f	10'-7"
	16"		20'-9"	16'-6"	14'-5"	18'-2"	14'-5"	12'-6"	15'-9" f	13'-1"	12'-2"	10'-5"	10'-5" f	---
	24"		18'-2"	14'-5"	12'-6"	14'-11" f	12'-6"	10'-7"	12'-11" f	11'-1"	---	---	---	---

- Table Notes:**
1. The Composite Limiting Wall Heights for Interior Nonstructural Studs were calculated using ICC-ES AC86-2012
 2. The minimum Safety Factor was 1.508 for 5 psf & 10psf, and 2.327 for 15psf
 3. Gypsum Board must be applied for the full height to each Stud flange and installed using #6 Type S Drywall screws spaced a maximum of 12" on-center for Studs spaced 24" apart, and 16" on center for Studs spaced 12" & 16" apart.
 4. Web height to thickness ratio, h/t, exceeds 200. Web must have bearing stiffeners in accordance with AISI S100. No holes or punch-outs are permitted in the web.
 5. Stud end bearing to be a minimum of 1".
 6. Minimum steel material yield strength to be at least 33ksi.
 7. "f" denotes flexural stress control the allowable wall height.
 8. No fasteners are required to secure the Stud to the Track.



INTERIOR NON-STRUCTURAL COMPOSITE WALL HEIGHTS

Section	"Spacing (in, o.c.)"	Fy (ksi)	5 psf			7.5 psf			10 psf			15 psf		
			L/120	L/240	L/360	L/120	L/240	L/360	L/120	L/240	L/360	L/120	L/240	L/360
362S125-30	12"	33	22'-10"	18'-3"	16'-4"	19'-11"	16'-0"	14'-3"	18'-1"	14'-6"	12'-11"	12'-8"	12'-8" f	10'-11"
	16"		20'-8"	16'-7"	14'-10"	18'-1"	14'-6"	12'-11"	16'-5"	13'-2"	11'-6"	11'-0"	11'-0" f	---
	24"		18'-1"	14'-6"	12'-11"	15'-9" f	12'-8"	10'-11"	13'-8" f	11'-4"	---	---	---	---
362S125-33	12"	33	24'-2"	19'-2"	16'-9"	21'-1"	16'-9"	14'-8"	19'-2"	15'-3"	13'-4"	13'-5"	13'-4"	11'-4"
	16"		21'-11"	17'-5"	15'-3"	19'-2"	15'-3"	13'-4"	17'-5"	13'-10"	11'-11"	11'-8"	11'-8" f	10'-1"
	24"		19'-2"	15'-3"	13'-4"	16'-8" f	13'-4"	11'-4"	14'-5" f	11'-11"	10'-1"	---	---	---
400S125-184	12"	33	19'-3" f	17'-6"	15'-4"	15'-9" f	15'-4"	13'-4"	13'-8" f	13'-8" f	12'-2"	8'-11"	8'-11" f	8'-11" f
	16"		16'-8" f	15'-11"	13'-11"	13'-8" f	13'-8" f	12'-2"	11'-10" f	11'-10" f	11'-0"	7'-9"	7'-9" f	7'-9" f
	24"		13'-8" f	13'-8" f	12'-2"	11'-2" f	11'-2" f	10'-7"	9'-8" f	9'-8" f	9'-7"	---	---	---
400S125-27	12"	33	24'-6"	19'-5"	17'-0"	21'-5"	17'-0"	14'-10"	18'-8" f	15'-5"	13'-6"	12'-3"	12'-3" f	11'-8"
	16"		22'-3"	17'-8"	15'-5"	18'-8" f	15'-5"	13'-6"	16'-2" f	14'-0"	12'-2"	10'-8"	10'-8" f	10'-6"
	24"		18'-8" f	15'-5"	13'-6"	15'-3" f	13'-6"	11'-8"	13'-3" f	12'-2"	10'-6"	---	---	---
400S125-30	12"	33	24'-6"	19'-5"	17'-0"	21'-5"	17'-0"	14'-10"	19'-5"	15'-5"	13'-6"	13'-2"	13'-2"	11'-7"
	16"		22'-3"	17'-8"	15'-5"	19'-5"	15'-5"	13'-6"	17'-5"	14'-0"	12'-2"	11'-5"	11'-5"	10'-4"
	24"		19'-5"	15'-5"	13'-6"	16'-5"	13'-6"	11'-7"	14'-2"	12'-2"	10'-4"	---	---	---
400S125-33	12"	33	25'-3"	20'-1"	17'-6"	22'-1"	17'-6"	20'-1"	20'-1"	15'-11"	13'-11"	13'-11"	13'-11"	12'-0"
	16"		22'-11"	18'-3"	15'-11"	20'-1"	15'-11"	18'-3"	18'-3"	14'-5"	12'-7"	12'-1"	12'-1"	10'-9"
	24"		20'-1"	15'-11"	13'-11"	17'-3"	13'-11"	15'-0"	15'-0"	12'-7"	10'-9"	9'-10"	9'-10"	---
550S125-27	12"	33	30'-4"	24'-8"	21'-10"	26'-9"	21'-10"	19'-4"	23'-2"	20'-0"	17'-8"	---	---	---
	16"		27'-11"	22'-8"	20'-0"	23'-2"	20'-0"	17'-8"	20'-1"	18'-4"	16'-0"	---	---	---
	24"		23'-2"	20'-0"	17'-8"	18'-11"	17'-8"	15'-5"	16'-5"	16'-0"	---	---	---	---
550S125-30	12"	33	30'-5"	24'-10"	22'-0"	27'-0"	22'-0"	19'-5"	24'-10"	20'-2"	17'-10"	16'-4"	16'-4"	15'-7"
	16"		28'-0"	22'-9"	20'-2"	24'-10"	20'-2"	17'-10"	21'-7"	18'-6"	16'-2"	---	---	---
	24"		24'-10"	20'-2"	17'-10"	20'-4"	17'-10"	15'-7"	17'-7"	16'-2"	---	---	---	---
600S125-274	12"	33	32'-5"	26'-9"	23'-5"	26'-5"	23'-5"	20'-5"	22'-11"	21'-3"	16'-10"	---	---	---
	16"		28'-1"	24'-4"	21'-3"	22'-11"	21'-3"	18'-7"	19'-10"	19'-4"	14'-7"	---	---	---
	24"		22'-11"	21'-3"	18'-7"	18'-8"	18'-7"	16'-1"	16'-2"	16'-2"	---	---	---	---
600S125-30	12"	33	34'-2"	27'-1"	23'-8"	28'-11"	23'-8"	20'-8"	25'-0"	21'-6"	18'-9"	16'-5"	16'-5"	16'-5"
	16"		30'-8"	24'-7"	21'-6"	25'-0"	21'-6"	18'-9"	21'-8"	19'-6"	17'-1"	---	---	---
	24"		25'-0"	21'-6"	18'-9"	20'-5"	18'-9"	16'-5"	17'-8"	17'-1"	---	---	---	---
600S125-33	12"	33	35'-4"	28'-1"	24'-6"	30'-10"	24'-6"	21'-5"	27'-10"	22'-3"	19'-5"	18'-4"	18'-4"	16'-11"
	16"		32'-1"	25'-6"	22'-3"	27'-10"	22'-3"	19'-5"	24'-1"	20'-3"	17'-8"	15'-10"	15'-10"	---
	24"		27'-10"	22'-3"	19'-5"	22'-9"	19'-5"	16'-11"	19'-8"	17'-8"	---	---	---	---

Table Notes:

1. The Composite Limiting Wall Heights for Interior Nonstructural Studs were calculated using ICC-ES AC86-2012
2. The minimum Safety Factor was 1.508 for 5 psf & 10psf, and 2.327 for 15psf
3. Gypsum Board must be applied for the full height to each Stud flange and installed using #6 Type S Drywall screws spaced a maximum of 12" on-center for Studs spaced 24" apart, and 16" on center for Studs spaced 12" & 16" apart.
4. Web height to thickness ratio, h/t, exceeds 200. Web must have bearing stiffeners in accordance with AISI S100. No holes or punch-outs are permitted in the web.
5. Stud end bearing to be a minimum of 1".
6. Minimum steel material yield strength to be at least 33ksi.
7. "f" denotes flexural stress control the allowable wall height.
8. No fasteners are required to secure the Stud to the Track.



INTERIOR NON-STRUCTURAL NON-COMPOSITE WALL HEIGHTS

Section	Fy (ksi)	Spacing (in) oc	5 psf			10 psf			15 psf		
			120	240	360	120	240	360	120	240	360
162S125-18	33	12	9'6"	7'10"	6'11"	6'8"	6'1"	5'5"	5'2"	5'2"	4'8"
162S125-18	33	16	8'3"	7'1"	6'3"	5'10"	5'6"	4'11"	4'6"	4'6"	4'3"
162S125-18	33	24	6'8"	6'1"	5'5"	4'9"	4'9"	4'3"	3'8"e	3'8"e	3'8"e
162S125-27	33	12	11'3"	9'0"	7'10"	8'10"	7'1"	6'3"	6'10"	6'3"	5'5"
162S125-27	33	16	10'3"	8'2"	7'2"	7'7"	6'6"	5'8"	5'11"	5'8"	4'11"
162S125-27	33	24	8'10"	7'1"	6'3"	6'3"	5'8"	4'11"	4'10"	4'10"	4'4"
162S125-30	33	12	11'8"	9'3"	8'1"	9'3"	7'4"	6'5"	7'3"	6'5"	5'7"
162S125-30	33	16	10'7"	8'5"	7'4"	8'2"	6'8"	5'10"	6'4"	5'10"	5'1"
162S125-30	33	24	9'3"	7'4"	6'5"	6'8"	5'10"	5'1"	5'2"	5'1"	4'5"
162S125-33	33	12	12'0"	9'7"	8'4"	9'6"	7'7"	6'8"	7'10"	6'8"	5'10"
162S125-33	33	16	10'11"	8'8"	7'7"	8'8"	6'11"	6'0"	6'9"	6'0"	5'3"
162S125-33	33	24	9'6"	7'7"	6'8"	7'1"	6'0"	5'3"	5'6"	5'3"	4'7"
250S125-18	33	12	12'4"	10'9"	9'6"	8'9"	8'5"	7'6"	6'9"	6'9"	6'6"
250S125-18	33	16	10'8"	9'8"	8'7"	7'7"	7'7"	6'9"	5'10"e	5'10"e	5'10"e
250S125-18	33	24	8'9"	8'5"	7'6"	6'2"e	6'2"e	5'10"e	4'9"e	4'9"e	4'9"e
250S125-27	33	12	15'7"	12'5"	10'10"	11'7"	9'10"	8'7"	9'0"	8'7"	7'6"
250S125-27	33	16	14'2"	11'3"	9'11"	10'1"	8'11"	7'10"	7'10"	7'10"	6'10"
250S125-27	33	24	11'7"	9'10"	8'7"	8'3"	7'10"	6'10"	6'4"	6'4"	5'11"
250S125-30	33	12	16'1"	12'10"	11'3"	12'5"	10'2"	8'11"	9'8"	8'10"	7'9"
250S125-30	33	16	14'7"	11'8"	10'2"	10'9"	9'3"	8'1"	8'4"	8'1"	7'1"
250S125-30	33	24	12'5"	10'2"	8'11"	8'10"	8'1"	7'1"	6'10"	6'10"	6'2"
250S125-33	33	12	16'8"	13'3"	11'7"	13'2"	10'6"	9'2"	10'4"	9'2"	8'0"
250S125-33	33	16	15'1"	12'1"	10'6"	11'7"	9'6"	8'4"	8'11"	8'4"	7'4"
250S125-33	33	24	13'2"	10'6"	9'2"	9'5"	8'4"	7'4"	7'4"	7'3"	6'4"
250S125-43	33	12	18'2"	14'5"	12'7"	14'5"	11'5"	10'0"	12'4"	10'0"	8'9"
250S125-43	33	16	16'6"	13'1"	11'5"	13'1"	10'5"	9'1"	10'8"	9'1"	7'11"
250S125-43	33	24	14'5"	11'5"	10'0"	11'3"	9'1"	7'11"	8'9"	7'11"	6'11"
350S125-18	33	12	14'6"	13'10"	12'3"	10'3"	10'3"	9'8"	7'11"e	7'11"e	7'11"e
350S125-18	33	16	12'7"	12'6"	11'1"	8'11"e	8'11"e	8'8"e	6'11"e	6'11"e	6'11"e
350S125-18	33	24	10'3"	10'3"	9'8"	7'3"e	7'3"e	7'3"e	5'7"e	5'7"e	5'7"e
350S125-27	33	12	19'6"	16'1"	14'1"	13'10"	12'9"	11'2"	10'8"	10'8"	9'9"
350S125-27	33	16	16'11"	14'7"	12'10"	11'11"	11'7"	10'1"	9'3"	9'3"	8'10"
350S125-27	33	24	13'10"	12'9"	11'2"	9'9"	9'9"	8'10"	7'7"e	7'7"e	7'7"e
350S125-30	33	12	20'10"	16'7"	14'6"	14'10"	13'2"	11'6"	11'6"	11'6"	10'1"
350S125-30	33	16	18'2"	15'1"	13'2"	12'10"	11'11"	10'6"	9'11"	9'11"	9'1"
350S125-30	33	24	14'10"	13'2"	11'6"	10'6"	10'5"	9'1"	8'1"	8'1"	8'0"
350S125-33	33	12	21'7"	17'2"	15'0"	16'0"	13'7"	11'11"	12'5"	11'10"	10'5"
350S125-33	33	16	19'7"	15'7"	13'8"	13'10"	12'4"	10'10"	10'9"	10'9"	9'5"
350S125-33	33	24	16'0"	13'7"	11'11"	11'4"	10'9"	9'5"	8'9"	8'9"	8'3"
362S125-18	33	12	14'10"	14'3"	12'7"	10'6"	10'6"	9'11"	8'1"e	8'1"e	8'1"e
362S125-18	33	16	12'10"	12'10"	11'5"	9'1"e	9'1"e	8'11"e	7'0"e	7'0"e	7'0"e
362S125-18	33	24	10'6"	10'6"	9'11"	7'5"e	7'5"e	7'5"e	5'9"e	5'9"e	5'9"e

INTERIOR NON-STRUCTURAL NON-COMPOSITE WALL HEIGHTS

Section	Fy (ksi)	Spacing (in) oc	5 psf			10 psf			15 psf		
			120	240	360	120	240	360	120	240	360
362S125-27	33	12	19'11"	16'6"	14'6"	14'1"	13'1"	11'5"	10'11"	10'11"	10'0"
362S125-27	33	16	17'3"	15'0"	13'2"	12'2"	11'11"	10'5"	9'5"	9'5"	9'1"
362S125-27	33	24	14'1"	13'1"	11'5"	9'11"	9'11"	9'1"	7'8" e	7'8" e	7'8" e
362S125-30	33	12	21'4"	17'1"	14'11"	15'1"	13'6"	11'10"	11'8"	11'8"	10'4"
362S125-30	33	16	18'6"	15'6"	13'7"	13'1"	12'3"	10'9"	10'2"	10'2"	9'4"
362S125-30	33	24	15'1"	13'6"	11'10"	10'8"	10'8"	9'4"	8'3"	8'3"	8'2"
362S125-33	33	12	22'2"	17'8"	15'5"	16'4"	14'0"	12'3"	12'8"	12'2"	10'8"
362S125-33	33	16	20'0"	16'1"	14'0"	14'2"	12'8"	11'2"	10'11"	10'11"	9'9"
362S125-33	33	24	16'4"	14'0"	12'3"	11'6"	11'1"	9'9"	8'11"	8'11"	8'6"
400S125-18	33	12	15'7" e	15'4" e	13'7" e	11'0" e	11'0" e	10'8" e	8'6" e	8'6" e	8'6" e
400S125-18	33	16	13'6" e	13'6" e	12'4" e	9'7" e	9'7" e	9'7" e	7'5" e	7'5" e	7'5" e
400S125-18	33	24	11'0" e	11'0" e	10'8" e	7'9" e	7'9" e	7'9" e	6'0" e	6'0" e	6'0" e
400S125-27	33	12	21'0"	17'10"	15'8"	14'10"	14'2"	12'4"	11'6"	11'6"	10'10"
400S125-27	33	16	18'2"	16'2"	14'2"	12'10"	12'10"	11'3"	9'11"	9'11"	9'10"
400S125-27	33	24	14'10"	14'2"	12'4"	10'6"	10'6"	9'10"	8'2" e	8'2" e	8'2" e
400S125-30	33	12	22'7"	18'5"	16'2"	15'11"	14'7"	12'10"	12'4"	12'4"	11'2"
400S125-30	33	16	19'7"	16'9"	14'8"	13'10"	13'3"	11'7"	10'8"	10'8"	10'2"
400S125-30	33	24	15'11"	14'7"	12'10"	11'3"	11'3"	10'2"	8'9"	8'9"	8'9"
400S125-33	33	12	23'11"	19'1"	16'8"	17'3"	15'1"	13'3"	13'4"	13'2"	11'7"
400S125-33	33	16	21'1"	17'4"	15'2"	14'11"	13'9"	12'0"	11'7"	11'7"	10'6"
400S125-33	33	24	17'3"	15'1"	13'3"	12'2"	12'0"	10'6"	9'5"	9'5"	9'2"
600S125-27	33	12	26'3" e	24'5" e	21'6" e	18'6" e	18'6" e	17'0" e	14'4" e	14'4" e	14'4" e
600S125-27	33	16	22'8" e	22'2" e	19'6" e	16'1" e	16'1" e	15'4" e	12'5" e	12'5" e	12'5" e
600S125-27	33	24	18'6" e	18'6" e	17'0" e	13'1" e	13'1" e	13'1" e	10'2" e	10'2" e	10'2" e
600S125-30	33	12	28'3"	25'4"	22'4"	20'0"	20'0"	17'7"	15'6"	15'6"	15'4"
600S125-30	33	16	24'6"	23'0"	20'3"	17'4"	17'4"	15'11"	13'5" e	13'5" e	13'5" e
600S125-30	33	24	20'0"	20'0"	17'7"	14'2" e	14'2" e	13'11" e	10'11" e	10'11" e	10'11" e
600S125-33	33	12	30'7"	26'5"	23'1"	21'8"	20'10"	18'4"	16'9"	16'9"	15'11"
600S125-33	33	16	26'6"	23'11"	21'0"	18'9"	18'9"	16'7"	14'6"	14'6"	14'5"
600S125-33	33	24	21'8"	20'10"	18'4"	15'4"	15'4"	14'5"	11'10" e	11'10" e	11'10" e
800S125-30	33	12	32'1" e	31'7" e	27'11" e	22'8" e	22'8" e	21'11" e	17'7" e	17'7" e	17'7" e
800S125-30	33	16	27'10" e	27'10" e	25'3" e	19'8" e	19'8" e	19'8" e	15'3" e	15'3" e	15'3" e
800S125-30	33	24	22'8" e	22'8" e	21'11" e	16'1" e	16'1" e	16'1" e	12'5" e	12'5" e	12'5" e
800S125-33	33	12	34'11" e	33'0" e	29'1" e	24'8" e	24'8" e	22'11" e	19'1" e	19'1" e	19'1" e
800S125-33	33	16	30'3" e	29'10" e	26'4" e	21'4" e	21'4" e	20'9" e	16'7" e	16'7" e	16'7" e
800S125-33	33	24	24'8" e	24'8" e	22'11" e	17'5" e	17'5" e	17'5" e	13'6" e	13'6" e	13'6" e



INTERIOR NON-STRUCTURAL BRACED 48" O.C. WALL HEIGHTS

Section	Fy (ksi)	Spacing (in oc)	5 psf			10 psf			15 psf		
			120	240	360	120	240	360	120	240	360
162S125-18	33	12	8'10"	7'10"	6'11"	6'3"	6'1"	5'5"	4'10"	4'10"	4'8"
162S125-18	33	16	7'8"	7'1"	6'3"	5'5"	5'5"	4'11"	4'2"	4'2"	4'2"
162S125-18	33	24	6'3"	6'1"	5'5"	4'5"	4'5"	4'3"	3'6"	3'6"	3'6"
162S125-27	33	12	11'3"	9'0"	7'10"	8'3"	7'1"	6'3"	6'5"	6'3"	5'5"
162S125-27	33	16	10'1"	8'2"	7'2"	7'2"	6'6"	5'8"	5'6"	5'6"	4'11"
162S125-27	33	24	8'3"	7'1"	6'3"	5'10"	5'8"	4'11"	4'6"	4'6"	4'4"
162S125-30	33	12	11'8"	9'3"	8'1"	8'10"	7'4"	6'5"	6'10"	6'5"	5'7"
162S125-30	33	16	10'7"	8'5"	7'4"	7'8"	6'8"	5'10"	5'11"	5'10"	5'1"
162S125-30	33	24	8'10"	7'4"	6'5"	6'3"	5'10"	5'1"	4'10"	4'10"	4'5"
162S125-33	33	12	12'0"	9'7"	8'4"	9'6"	7'7"	6'8"	7'4"	6'8"	5'10"
162S125-33	33	16	10'11"	8'8"	7'7"	8'3"	6'11"	6'0"	6'4"	6'0"	5'3"
162S125-33	33	24	9'6"	7'7"	6'8"	6'8"	6'0"	5'3"	5'2"	5'2"	4'7"
250S125-18	33	12	12'2"	10'9"	9'6"	8'7"	8'5"	7'6"	6'8"	6'8"	6'6"
250S125-18	33	16	10'6"	9'8"	8'7"	7'5"	7'5"	6'9"	5'9"e	5'9"e	5'9"e
250S125-18	33	24	8'7"	8'5"	7'6"	6'1"e	6'1"e	5'10"e	4'8"e	4'8"e	4'8"e
250S125-27	33	12	15'7"	12'5"	10'10"	11'0"	9'10"	8'7"	8'7"	8'7"	7'6"
250S125-27	33	16	13'6"	11'3"	9'11"	9'7"	8'11"	7'10"	7'5"	7'5"	6'10"
250S125-27	33	24	11'0"	9'10"	8'7"	7'10"	7'10"	6'10"	6'1"	6'1"	5'11"
250S125-30	33	12	16'1"	12'10"	11'3"	11'9"	10'2"	8'11"	9'1"	8'10"	7'9"
250S125-30	33	16	14'5"	11'8"	10'2"	10'2"	9'3"	8'1"	7'11"	7'11"	7'1"
250S125-30	33	24	11'9"	10'2"	8'11"	8'4"	8'1"	7'1"	6'5"	6'5"	6'2"
250S125-33	33	12	16'8"	13'3"	11'7"	12'7"	10'6"	9'2"	9'9"	9'2"	8'0"
250S125-33	33	16	15'1"	12'1"	10'6"	10'11"	9'6"	8'4"	8'5"	8'4"	7'4"
250S125-33	33	24	12'7"	10'6"	9'2"	8'11"	8'4"	7'4"	6'11"	6'11"	6'4"
350S125-18	33	12	13'6"	13'6"	12'3"	9'7"	9'7"	9'7"	7'5"e	7'5"e	7'5"e
350S125-18	33	16	11'8"	11'8"	11'1"	8'3"e	8'3"e	8'3"e	6'5"e	6'5"e	6'5"e
350S125-18	33	24	9'7"	9'7"	9'7"	6'9"e	6'9"e	6'9"e	5'3"e	5'3"e	5'3"e
350S125-27	33	12	18'2"	16'1"	14'1"	12'10"	12'9"	11'2"	9'11"	9'11"	9'9"
350S125-27	33	16	15'9"	14'7"	12'10"	11'2"	11'2"	10'1"	8'7"	8'7"	8'7"
350S125-27	33	24	12'10"	12'9"	11'2"	9'1"	9'1"	8'10"	7'0"	7'0"	7'0"
350S125-30	33	12	19'6"	16'7"	14'6"	13'10"	13'2"	11'6"	10'8"	10'8"	10'1"
350S125-30	33	16	16'11"	15'1"	13'2"	12'0"	11'11"	10'6"	9'3"	9'3"	9'1"
350S125-30	33	24	13'10"	13'2"	11'6"	9'9"	9'9"	9'1"	7'7"	7'7"	7'7"
350S125-33	33	12	21'1"	17'2"	15'0"	14'11"	13'7"	11'11"	11'7"	11'7"	10'5"
350S125-33	33	16	18'3"	15'7"	13'8"	12'11"	12'4"	10'10"	10'0"	10'0"	9'5"
350S125-33	33	24	14'11"	13'7"	11'11"	10'7"	10'7"	9'5"	8'2"	8'2"	8'2"

INTERIOR NON-STRUCTURAL BRACED 48" O.C. WALL HEIGHTS

Section	Fy (ksi)	Spacing (in) oc	5 psf			10 psf			15 psf		
			120	240	360	120	240	360	120	240	360
362S125-18	33	12	13'9"	13'9"	12'7"	9'9"	9'9"	9'9"	7'7"e	7'7"e	7'7"e
362S125-18	33	16	11'11"	11'11"	11'5"	8'5"e	8'5"e	8'5"e	6'6"e	6'6"e	6'6"e
362S125-18	33	24	9'9"	9'9"	9'9"	6'11"e	6'11"e	6'11"e	5'4"e	5'4"e	5'4"e
362S125-27	33	12	18'6"	16'6"	14'6"	13'1"	13'1"	11'5"	10'2"	10'2"	10'0"
362S125-27	33	16	16'1"	15'0"	13'2"	11'4"	11'4"	10'5"	8'9"	8'9"	8'9"
362S125-27	33	24	13'1"	13'1"	11'5"	9'3"	9'3"	9'1"	7'2"	7'2"	7'2"
362S125-30	33	12	19'11"	17'1"	14'11"	14'1"	13'6"	11'10"	10'11"	10'11"	10'4"
362S125-30	33	16	17'3"	15'6"	13'7"	12'2"	12'2"	10'9"	9'5"	9'5"	9'4"
362S125-30	33	24	14'1"	13'6"	11'10"	10'0"	10'0"	9'4"	7'9"	7'9"	7'9"
362S125-33	33	12	21'6"	17'8"	15'5"	15'3"	14'0"	12'3"	11'9"	11'9"	10'8"
362S125-33	33	16	18'8"	16'1"	14'0"	13'2"	12'8"	11'2"	10'2"	10'2"	9'9"
362S125-33	33	24	15'3"	14'0"	12'3"	10'9"	10'9"	9'9"	8'4"	8'4"	8'4"
400S125-18	33	12	14'6"e	14'6"e	13'7"e	10'3"e	10'3"e	10'3"e	7'11"e	7'11"e	7'11"e
400S125-18	33	16	12'7"e	12'7"e	12'4"e	8'11"e	8'11"e	8'11"e	6'10"e	6'10"e	6'10"e
400S125-18	33	24	10'3"e	10'3"e	10'3"e	7'3"e	7'3"e	7'3"e	5'7"e	5'7"e	5'7"e
400S125-27	33	12	19'6"	17'10"	15'8"	13'10"	13'10"	12'4"	10'8"	10'8"	10'8"
400S125-27	33	16	16'11"	16'2"	14'2"	12'0"	12'0"	11'3"	9'3"	9'3"	9'3"
400S125-27	33	24	13'10"	13'10"	12'4"	9'9"	9'9"	9'9"	7'7"e	7'7"e	7'7"e
400S125-30	33	12	21'0"	18'5"	16'2"	14'10"	14'7"	12'10"	11'6"	11'6"	11'2"
400S125-30	33	16	18'2"	16'9"	14'8"	12'10"	12'10"	11'7"	10'0"	10'0"	10'0"
400S125-30	33	24	14'10"	14'7"	12'10"	10'6"	10'6"	10'2"	8'2"	8'2"	8'2"
400S125-33	33	12	22'9"	19'1"	16'8"	16'1"	15'1"	13'3"	12'5"	12'5"	11'7"
400S125-33	33	16	19'8"	17'4"	15'2"	13'11"	13'9"	12'0"	10'9"	10'9"	10'6"
400S125-33	33	24	16'1"	15'1"	13'3"	11'4"	11'4"	10'6"	8'10"	8'10"	8'10"
600S125-27	33	12	26'0"e	24'5"e	21'6"e	18'5"e	18'5"e	17'0"e	14'3"e	14'3"e	14'3"e
600S125-27	33	16	22'6"e	22'2"e	19'6"e	15'11"e	15'11"e	15'4"e	12'4"e	12'4"e	12'4"e
600S125-27	33	24	18'5"e	18'5"e	17'0"e	13'0"e	13'0"e	13'0"e	10'1"e	10'1"e	10'1"e
600S125-30	33	12	28'1"	25'4"	22'4"	19'10"	19'10"	17'7"	15'4"	15'4"	15'4"
600S125-30	33	16	24'4"	23'0"	20'3"	17'2"	17'2"	15'11"	13'4"e	13'4"e	13'4"e
600S125-30	33	24	19'10"	19'10"	17'7"	14'0"e	14'0"e	13'11"e	10'10"e	10'10"e	10'10"e
600S125-33	33	12	30'5"	26'5"	23'1"	21'6"	20'10"	18'4"	16'8"	16'8"	15'11"
600S125-33	33	16	26'4"	23'11"	21'0"	18'7"	18'7"	16'7"	14'5"	14'5"	14'5"
600S125-33	33	24	21'6"	20'10"	18'4"	15'2"	15'2"	14'5"	11'9"e	11'9"e	11'9"e
800S125-30	33	12	32'1"e	31'7"e	27'11"e	22'8"e	22'8"e	21'11"e	17'7"e	17'7"e	17'7"e
800S125-30	33	16	27'10"e	27'10"e	25'3"e	19'8"e	19'8"e	19'8"e	15'3"e	15'3"e	15'3"e
800S125-30	33	24	22'8"e	22'8"e	21'11"e	16'1"e	16'1"e	16'1"e	12'5"e	12'5"e	12'5"e
800S125-33	33	12	34'11"e	33'0"e	29'1"e	24'8"e	24'8"e	22'11"e	19'1"e	19'1"e	19'1"e
800S125-33	33	16	30'3"e	29'10"e	26'4"e	21'4"e	21'4"e	20'9"e	16'7"e	16'7"e	16'7"e
800S125-33	33	24	24'8"e	24'8"e	22'11"e	17'5"e	17'5"e	17'5"e	13'6"e	13'6"e	13'6"e



ALLOWABLE CEILING SPANS - L/240

Section	Fy (ksi)	4 psf						6 psf						13 psf					
		Lateral Support of Compression Flange			Midspan			Lateral Support of Compression Flange			Midspan			Lateral Support of Compression Flange			Midspan		
		Unsupported Joist Spacing (in) o.c.			Joist Spacing (in) o.c.			Unsupported Joist Spacing (in) o.c.			Joist Spacing (in) o.c.			Unsupported Joist Spacing (in) o.c.			Joist Spacing (in) o.c.		
	12	16	24	12	16	24	12	16	24	12	16	24	12	16	24	12	16	24	
162S125-18	33	7' 6"	6' 10"	6' 1"	8' 6"	7' 8"	6' 7"	6' 7"	6' 1"	5' 4"	7' 4"	6' 7"	5' 9"	5' 2"	4' 8"	3' 11"	5' 7"	5' 0"	4' 2"
162S125-27	33	8' 11"	8' 2"	7' 3"	9' 8"	8' 10"	7' 8"	7' 11"	7' 3"	6' 6"	8' 6"	7' 8"	6' 8"	6' 4"	5' 9"	4' 11"	6' 6"	5' 11"	5' 2"
162S125-30	33	9' 4"	8' 6"	7' 7"	10' 0"	9' 1"	7' 11"	8' 3"	7' 7"	6' 9"	8' 9"	7' 11"	6' 11"	6' 7"	6' 0"	5' 3"	6' 9"	6' 1"	5' 4"
162S125-33	33	9' 9"	8' 11"	7' 11"	10' 4"	9' 5"	8' 2"	8' 8"	7' 11"	7' 0"	9' 0"	8' 2"	7' 2"	6' 10"	6' 4"	5' 6"	7' 0"	6' 4"	5' 6"
162S137-27	33	10' 1"	9' 2"	8' 0"	10' 1"	9' 2"	8' 0"	8' 10"	8' 0"	7' 0"	8' 10"	8' 0"	7' 0"	6' 10"	6' 2"	5' 5"	6' 10"	6' 2"	5' 5"
162S137-30	33	10' 5"	9' 6"	8' 3"	10' 5"	9' 6"	8' 3"	9' 1"	8' 3"	7' 3"	9' 1"	8' 3"	7' 3"	7' 0"	6' 5"	5' 7"	7' 0"	6' 5"	5' 7"
162S137-33	33	10' 9"	9' 9"	8' 7"	10' 9"	9' 9"	8' 7"	9' 5"	8' 7"	7' 6"	9' 5"	8' 7"	7' 6"	7' 3"	6' 7"	5' 9"	7' 3"	6' 7"	5' 9"
250S125-18	33	8' 8"	8' 0"	7' 1"	11' 7"	10' 6"	9' 1"	7' 9"	7' 1"	6' 4"	10' 1"	9' 1"	7' 11"	6' 2"	5' 8"	5' 0" e	7' 8"	6' 8"	5' 5" e
250S125-27	33	10' 0"	9' 3"	8' 3"	13' 5"	12' 2"	10' 7"	8' 11"	8' 3"	7' 4"	11' 8"	10' 7"	9' 3"	7' 2"	6' 8"	5' 11"	9' 0"	8' 2"	7' 2"
250S125-30	33	10' 4"	9' 7"	8' 6"	13' 10"	12' 7"	10' 11"	9' 3"	8' 6"	7' 7"	12' 1"	10' 11"	9' 7"	7' 5"	6' 11"	6' 2"	9' 4"	8' 5"	7' 4"
250S125-33	33	10' 10"	9' 11"	8' 10"	14' 3"	13' 0"	11' 4"	9' 7"	8' 10"	7' 11"	12' 6"	11' 4"	9' 11"	7' 9"	7' 1"	6' 4"	9' 7"	8' 9"	7' 7"
250S137-27	33	11' 4"	10' 6"	9' 5"	14' 0"	12' 9"	11' 1"	10' 2"	9' 5"	8' 5"	12' 3"	11' 1"	9' 9"	8' 3"	7' 8"	6' 10"	9' 6"	8' 7"	7' 6"
250S137-30	33	11' 9"	10' 10"	9' 8"	14' 5"	13' 2"	11' 6"	10' 6"	9' 8"	8' 8"	12' 8"	11' 6"	10' 0"	8' 6"	7' 11"	7' 1"	9' 9"	8' 10"	7' 9"
250S137-33	33	12' 2"	11' 3"	10' 1"	14' 11"	13' 7"	11' 10"	10' 10"	10' 1"	9' 0"	13' 1"	11' 10"	10' 4"	8' 10"	8' 2"	7' 4"	10' 1"	9' 2"	8' 0"
250S162-33	33	13' 11"	12' 10"	11' 6"	15' 8"	14' 3"	12' 5"	12' 5"	11' 6"	10' 4"	13' 8"	12' 5"	10' 10"	10' 1"	9' 4"	8' 4"	10' 7"	9' 7"	8' 5"
350S125-18	33	9' 5"	8' 9"	7' 9"	12' 11"	11' 10"	10' 3"	8' 5"	7' 9"	6' 10"	11' 5"	10' 3"	8' 9"	6' 8"	6' 2"	5' 5" e	8' 6" e	7' 6" e	6' 3" e
350S125-27	33	10' 10"	10' 0"	9' 0"	15' 4"	14' 2"	12' 7"	9' 9"	9' 0"	8' 0"	13' 8"	12' 7"	11' 0"	7' 10"	7' 3"	6' 6"	10' 9"	9' 7"	8' 2"
350S125-30	33	11' 3"	10' 5"	9' 3"	15' 10"	14' 7"	13' 1"	10' 1"	9' 3"	8' 4"	14' 2"	13' 1"	11' 7"	8' 2"	7' 6"	6' 9"	11' 3"	10' 2"	8' 8"
350S125-33	33	11' 8"	10' 9"	9' 7"	16' 6"	15' 2"	13' 6"	10' 5"	9' 7"	8' 7"	14' 8"	13' 6"	12' 1"	8' 5"	7' 9"	6' 11"	11' 10"	10' 9"	9' 2"
350S137-27	33	12' 3"	11' 4"	10' 2"	17' 6"	16' 3"	14' 5"	11' 0"	10' 2"	9' 2"	15' 8"	14' 5"	12' 7"	8' 11"	8' 4"	7' 5"	12' 3"	11' 1"	9' 4"
350S137-30	33	12' 8"	11' 9"	10' 6"	18' 1"	16' 8"	14' 10"	11' 4"	10' 6"	9' 5"	16' 2"	14' 10"	13' 0"	9' 3"	8' 6"	7' 8"	12' 8"	11' 6"	9' 11"
350S137-33	33	13' 2"	12' 2"	10' 11"	18' 8"	17' 3"	15' 4"	11' 9"	10' 11"	9' 9"	16' 9"	15' 4"	13' 5"	9' 6"	8' 10"	7' 11"	13' 1"	11' 10"	10' 4"
350S162-33	33	14' 11"	13' 10"	12' 5"	20' 3"	18' 5"	16' 1"	13' 5"	12' 5"	11' 1"	17' 9"	16' 1"	14' 1"	10' 11"	10' 1"	9' 1"	13' 8"	12' 5"	10' 10"
362S125-18	33	9' 6"	8' 10"	7' 10"	13' 1"	12' 0"	10' 5"	8' 6"	7' 10"	6' 11"	11' 6"	10' 5"	8' 11"	6' 9"	6' 2"	5' 6" e	8' 7" e	7' 8" e	6' 5" e
362S125-27	33	10' 11"	10' 2"	9' 1"	15' 5"	14' 3"	12' 9"	9' 10"	9' 1"	8' 1"	13' 10"	12' 9"	11' 2"	7' 11"	7' 4"	6' 7"	10' 10"	9' 9"	8' 3"
362S125-30	33	11' 4"	10' 6"	9' 4"	16' 0"	14' 9"	13' 2"	10' 2"	9' 4"	8' 5"	14' 4"	13' 2"	11' 9"	8' 3"	7' 7"	6' 9"	11' 5"	10' 4"	8' 9"
362S125-33	33	11' 9"	10' 10"	9' 9"	16' 8"	15' 4"	13' 8"	10' 6"	9' 9"	8' 8"	14' 10"	13' 8"	12' 3"	8' 6"	7' 10"	7' 0"	11' 11"	10' 11"	9' 4"
362S137-27	33	12' 5"	11' 5"	10' 3"	17' 8"	16' 4"	14' 8"	11' 1"	10' 3"	9' 3"	15' 10"	14' 8"	12' 11"	9' 0"	8' 4"	7' 6"	12' 7"	11' 3"	9' 6"
362S137-30	33	12' 10"	11' 10"	10' 7"	18' 3"	16' 10"	15' 2"	11' 6"	10' 7"	9' 6"	16' 4"	15' 2"	13' 4"	9' 4"	8' 7"	7' 9"	13' 0"	11' 10"	10' 1"
362S137-33	33	13' 3"	12' 3"	11' 0"	18' 10"	17' 5"	15' 7"	11' 11"	11' 0"	9' 10"	16' 11"	15' 7"	13' 9"	9' 8"	8' 11"	8' 0"	13' 5"	12' 2"	10' 8"
362S162-33	33	15' 1"	14' 0"	12' 6"	20' 10"	18' 11"	16' 6"	13' 6"	12' 6"	11' 3"	18' 2"	16' 6"	14' 5"	11' 0"	10' 2"	9' 2"	14' 1"	12' 9"	11' 2"



ALLOWABLE CEILING SPANS - L/240

Section	F _y (ksi)	4 psf						6 psf						13 psf					
		Lateral Support of Compression Flange			Midspan			Lateral Support of Compression Flange			Midspan			Lateral Support of Compression Flange			Midspan		
		Unsupported Joist Spacing (in) o.c.			Joist Spacing (in) o.c.			Unsupported Joist Spacing (in) o.c.			Joist Spacing (in) o.c.			Unsupported Joist Spacing (in) o.c.			Joist Spacing (in) o.c.		
	12	16	24	12	16	24	12	16	24	12	16	24	12	16	24	12	16	24	
400S125-18	33	9'9" e	9'1" e	8'1" e	13'5" e	12'4" e	10'10" e	8'9" e	8'1" e	7'2" e	11'11" e	10'10" e	9'3" e	7'0" e	6'5" e	5'8" e	9'0" e	8'0" e	6'8" e
400S125-27	33	11'3"	10'5"	9'4"	15'10"	14'8"	13'2"	10'1"	9'4"	8'4"	14'2"	13'2"	11'7"	8'2"	7'6"	6'9"	11'3"	10'2"	8'8"
400S125-30	33	11'8"	10'9"	9'7"	16'5"	15'2"	13'7"	10'5"	9'7"	8'7"	14'8"	13'7"	12'2"	8'5"	7'9"	6'11"	11'10"	10'9"	9'2"
400S125-33	33	12'1"	11'2"	10'0"	17'1"	15'9"	14'1"	10'10"	10'0"	8'11"	15'3"	14'1"	12'7"	8'9"	8'1"	7'3"	12'4"	11'4"	9'9"
400S137-27	33	12'8"	11'9"	10'6"	18'1"	16'9"	15'1"	11'5"	10'6"	9'5"	16'3"	15'1"	13'5"	9'3"	8'7"	7'8"	13'1"	11'9"	9'11" e
400S137-30	33	13'2"	12'2"	10'10"	18'8"	17'3"	15'6"	11'9"	10'10"	9'9"	16'9"	15'6"	13'10"	9'7"	8'10"	7'11"	13'6"	12'4"	10'6"
400S137-33	33	13'8"	12'7"	11'3"	19'4"	17'10"	16'0"	12'2"	11'3"	10'1"	17'4"	16'0"	14'4"	9'10"	9'2"	8'2"	14'0"	12'10"	11'1"
400S162-33	33	15'6"	14'4"	12'10"	22'0"	20'5"	17'10"	13'10"	12'10"	11'6"	19'8"	17'10"	15'7"	11'3"	10'5"	9'4"	15'2"	13'9"	12'0"
550S125-27	33	12'5"	11'6"	10'5"	17'11"	16'7"	14'10"	11'2"	10'5"	9'4"	16'1"	14'10"	13'3"	9'2"	8'6"	7'7"	13'0"	11'11"	10'5" e
550S125-30	33	12'10"	11'10"	10'8"	18'5"	17'1"	15'4"	11'6"	10'8"	9'7"	16'7"	15'4"	13'9"	9'5"	8'9"	7'10"	13'5"	12'5"	11'0" e
550S125-33	33	13'3"	12'3"	11'0"	19'0"	17'7"	15'10"	11'11"	11'0"	9'11"	17'1"	15'10"	14'2"	9'8"	9'0"	8'1"	13'11"	12'10"	11'6"
550S137-27	33	14'1"	13'0"	11'9"	20'4"	18'10"	17'0"	12'8"	11'9"	10'7"	18'4"	17'0"	15'4"	10'4"	9'7"	8'8"	15'0"	13'11" e	12'4" e
550S137-30	33	14'6"	13'5"	12'1"	20'10"	19'4"	17'5"	13'0"	12'1"	10'10"	18'9"	17'5"	15'9"	10'8"	9'10"	8'11"	15'5"	14'4"	12'9" e
550S137-33	33	14'11"	13'10"	12'5"	21'5"	19'11"	17'11"	13'5"	12'5"	11'2"	19'4"	17'11"	16'2"	10'11"	10'2"	9'2"	15'10"	14'8"	13'1"
550S162-33	33	17'0"	15'9"	14'2"	24'5"	22'8"	20'5"	15'3"	14'2"	12'9"	22'0"	20'5"	18'5"	12'6"	11'7"	10'5"	18'0"	16'8"	14'9" e
600S125-27	33	12'9" e	11'10" e	10'8" e	18'5" e	17'0" e	15'2" e	11'6" e	10'8" e	9'7" e	16'5" e	15'2" e	13'7" e	9'5" e	8'9" e	7'10" e	13'3" e	12'3" e	10'9" e
600S125-30	33	13'2"	12'2"	10'11"	18'11"	17'7"	15'9"	11'10"	10'11"	9'10"	17'0"	15'9"	14'0"	9'8"	8'11"	8'1"	13'9"	12'8"	11'4" e
600S125-33	33	13'7"	12'7"	11'3"	19'6"	18'1"	16'3"	12'2"	11'3"	10'2"	17'6"	16'3"	14'7"	9'11"	9'2"	8'4"	14'3"	13'2"	11'9"
600S137-27	33	14'5" e	13'4" e	12'1" e	20'9" e	19'2" e	17'3" e	13'0" e	12'0" e	10'10" e	18'7" e	17'3" e	15'5" e	10'7" e	9'10" e	8'10" e	15'1" e	14'0" e	12'4" e
600S137-30	33	14'10"	13'9"	12'4"	21'5"	19'10"	17'9"	13'4"	12'4"	11'2"	19'2"	17'9"	15'11"	10'11"	10'2"	9'1"	15'7"	14'5"	12'10" e
600S137-33	33	15'3"	14'2"	12'9"	22'0"	20'5"	18'4"	13'9"	12'9"	11'5"	19'10"	18'4"	16'6"	11'3"	10'5"	9'5"	16'1"	14'11"	13'4" e
600S162-33	33	17'5"	16'1"	14'6"	25'1"	23'3"	21'0"	15'7"	14'6"	13'1"	22'7"	21'0"	18'11"	12'9"	11'10"	10'8"	18'6"	17'2"	15'3" e

Notes:

- For unbraced sections, allowable moment based on AISI S100 section C3.1.2 with $KyLy = KtLt =$ listed span. For mid-span braced sections, allowable moment based on AISI S100 C3.1.2 with $KyLy = KtLt =$ (listed span)/2
- Safety factors based on 0.9W per AISI S220-11, B1(a).
- For spans listed with "e", web stiffeners are required at end reactions.
- For distortional buckling allowable moment, $k_f = 0$.
- Web crippling calculation based on bearing length = 1 inch.
- Web crippling and shear capacity have not been reduced for punch-outs. If web punch-outs occur near supports members must be checked for reduced shear and web crippling in accordance with AISI S100.
- Values are for simple span conditions.
- Moment of inertia for deflection is calculated at the maximum service level stress for the span and load listed. Note that this value may be higher than the effective I_{xx} listed in section property tables.



ALLOWABLE CEILING SPANS - L/360

Section	Fy (ksi)	4 psf						6 psf						13 psf					
		Lateral Support of Compression Flange						Lateral Support of Compression Flange						Lateral Support of Compression Flange					
		Unsupported Joist Spacing (in) o.c.			Midspan Joist Spacing (in) o.c.			Unsupported Joist Spacing (in) o.c.			Midspan Joist Spacing (in) o.c.			Unsupported Joist Spacing (in) o.c.			Midspan Joist Spacing (in) o.c.		
	12	16	24	12	16	24	12	16	24	12	16	24	12	16	24	12	16	24	
162S125-18	33	7'5"	6'9"	5'11"	7'5"	6'9"	5'11"	6'6"	5'11"	5'1"	6'6"	5'11"	5'1"	4'11"	4'6"	3'10"	4'11"	4'6"	3'10"
162S125-27	33	8'6"	7'8"	6'9"	8'6"	7'8"	6'9"	7'5"	6'9"	5'10"	7'5"	6'9"	5'10"	5'9"	5'2"	4'6"	5'9"	5'2"	4'6"
162S125-30	33	8'9"	7'11"	6'11"	8'9"	7'11"	6'11"	7'8"	6'11"	6'1"	7'8"	6'11"	6'1"	5'11"	5'4"	4'8"	5'11"	5'4"	4'8"
162S125-33	33	9'0"	8'2"	7'2"	9'0"	8'2"	7'2"	7'11"	7'2"	6'3"	7'11"	7'2"	6'3"	6'1"	5'6"	4'10"	6'1"	5'6"	4'10"
162S137-27	33	8'10"	8'0"	7'0"	8'10"	8'0"	7'0"	7'9"	7'0"	6'2"	7'9"	7'0"	6'2"	6'0"	5'5"	4'9"	6'0"	5'5"	4'9"
162S137-30	33	9'1"	8'3"	7'3"	9'1"	8'3"	7'3"	8'0"	7'3"	6'4"	8'0"	7'3"	6'4"	6'2"	5'7"	4'11"	6'2"	5'7"	4'11"
162S137-33	33	9'5"	8'7"	7'6"	9'5"	8'7"	7'6"	8'3"	7'6"	6'6"	8'3"	7'6"	6'6"	6'4"	5'9"	5'1"	6'4"	5'9"	5'1"
250S125-18	33	8'8"	8'0"	7'1"	10'3"	9'3"	8'1"	7'9"	7'1"	6'4"	8'11"	8'1"	7'0"	6'2"	5'8"	5'0"e	6'10"	6'2"	5'4"e
250S125-27	33	10'0"	9'3"	8'3"	11'9"	10'8"	9'4"	8'11"	8'3"	7'4"	10'3"	9'4"	8'1"	7'2"	6'8"	5'11"	7'11"	7'2"	6'3"
250S125-30	33	10'4"	9'7"	8'6"	12'1"	11'0"	9'7"	9'3"	8'6"	7'7"	10'7"	9'7"	8'5"	7'5"	6'11"	6'2"	8'2"	7'5"	6'5"
250S125-33	33	10'10"	9'11"	8'10"	12'6"	11'4"	9'11"	9'7"	8'10"	7'11"	10'11"	9'11"	8'8"	7'9"	7'1"	6'4"	8'5"	7'8"	6'8"
250S137-27	33	11'4"	10'6"	9'5"	12'3"	11'1"	9'9"	10'2"	9'5"	8'5"	10'8"	9'9"	8'6"	8'3"	7'6"	6'7"	8'3"	7'6"	6'7"
250S137-30	33	11'9"	10'10"	9'8"	12'8"	11'6"	10'0"	10'6"	9'8"	8'8"	11'0"	10'0"	8'9"	8'6"	7'9"	6'9"	8'6"	7'9"	6'9"
250S137-33	33	12'2"	11'3"	10'1"	13'1"	11'10"	10'4"	10'10"	10'1"	9'0"	11'5"	10'4"	9'1"	8'10"	8'0"	7'0"	8'10"	8'0"	7'0"
250S162-33	33	13'8"	12'5"	10'10"	13'8"	12'5"	10'10"	12'0"	10'10"	9'6"	12'0"	10'10"	9'6"	9'3"	8'5"	7'4"	9'3"	8'5"	7'4"
350S125-18	33	9'5"	8'9"	7'9"	12'11"	11'10"	10'3"	8'5"	7'9"	6'10"	11'5"	10'3"	8'9"	6'8"	6'2"	5'5"e	8'6"e	7'6"e	6'3"e
350S125-27	33	10'10"	10'0"	9'0"	15'2"	13'9"	12'0"	9'9"	9'0"	8'0"	13'3"	12'0"	10'6"	7'10"	7'3"	6'6"	10'2"	9'3"	8'1"
350S125-30	33	11'3"	10'5"	9'3"	15'8"	14'3"	12'5"	10'1"	9'3"	8'4"	13'8"	12'5"	10'10"	8'2"	7'6"	6'9"	10'7"	9'7"	8'4"
350S125-33	33	11'8"	10'9"	9'7"	16'2"	14'8"	12'10"	10'5"	9'7"	8'7"	14'2"	12'10"	11'3"	8'5"	7'9"	6'11"	10'11"	9'11"	8'8"
350S137-27	33	12'3"	11'4"	10'2"	15'10"	14'5"	12'7"	11'0"	10'2"	9'2"	13'10"	12'7"	11'0"	8'11"	8'4"	7'5"	10'8"	9'9"	8'6"
350S137-30	33	12'8"	11'9"	10'6"	16'4"	14'10"	13'0"	11'4"	10'6"	9'5"	14'3"	13'0"	11'4"	9'3"	8'6"	7'8"	11'0"	10'0"	8'9"
350S137-33	33	13'2"	12'2"	10'11"	16'11"	15'4"	13'5"	11'9"	10'11"	9'9"	14'9"	13'5"	11'9"	9'6"	8'10"	7'11"	11'5"	10'4"	9'1"
350S162-33	33	14'11"	13'10"	12'5"	17'9"	16'1"	14'1"	13'5"	12'5"	11'1"	15'6"	14'1"	12'3"	10'11"	10'1"	9'1"	11'11"	10'10"	9'6"
362S125-18	33	9'6"	8'10"	7'10"	13'1"	12'0"	10'5"	8'6"	7'10"	6'11"	11'6"	10'5"	8'11"	6'9"	6'2"	5'6"e	8'7"e	7'8"e	6'5"e
362S125-27	33	10'11"	10'2"	9'1"	15'5"	14'2"	12'4"	9'10"	9'1"	8'1"	13'7"	12'4"	10'9"	7'11"	7'4"	6'7"	10'6"	9'6"	8'3"
362S125-30	33	11'4"	10'6"	9'4"	16'0"	14'7"	12'9"	10'2"	9'4"	8'5"	14'1"	12'9"	11'2"	8'3"	7'7"	6'9"	10'10"	9'10"	8'7"
362S125-33	33	11'9"	10'10"	9'9"	16'8"	15'1"	13'2"	10'6"	9'9"	8'8"	14'6"	13'2"	11'6"	8'6"	7'10"	7'0"	11'3"	10'2"	8'11"
362S137-27	33	12'5"	11'5"	10'3"	16'3"	14'9"	12'11"	11'1"	10'3"	9'3"	14'3"	12'11"	11'3"	9'0"	8'4"	7'6"	11'0"	10'0"	8'9"
362S137-30	33	12'10"	11'10"	10'7"	16'10"	15'3"	13'4"	11'6"	10'7"	9'6"	14'8"	13'4"	11'8"	9'4"	8'7"	7'9"	11'4"	10'4"	9'0"
362S137-33	33	13'3"	12'3"	11'0"	17'4"	15'9"	13'9"	11'11"	11'0"	9'10"	15'2"	13'9"	12'0"	9'8"	8'11"	8'0"	11'9"	10'8"	9'4"
362S162-33	33	15'1"	14'0"	12'6"	18'2"	16'6"	14'5"	13'6"	12'6"	11'3"	15'11"	14'5"	12'7"	11'0"	10'2"	9'2"	12'3"	11'2"	9'9"



ALLOWABLE CEILING SPANS - L/360

Section	F _y (ksi)	4 psf						6 psf						13 psf					
		Lateral Support of Compression Flange						Lateral Support of Compression Flange						Lateral Support of Compression Flange					
		Unsupported Joist Spacing (in) o.c.			Midspan Joist Spacing (in) o.c.			Unsupported Joist Spacing (in) o.c.			Midspan Joist Spacing (in) o.c.			Unsupported Joist Spacing (in) o.c.			Midspan Joist Spacing (in) o.c.		
	12	16	24	12	16	24	12	16	24	12	16	24	12	16	24	12	16	24	
400S125-18	33	9'9"e	9'1"e	8'1"e	13'5"e	12'4"e	10'10"e	8'9"e	8'1"e	7'2"e	11'11"e	10'10"e	9'3"e	7'0"e	6'5"e	5'8"e	9'0"e	8'0"e	6'8"e
400S125-27	33	11'3"	10'5"	9'4"	15'10"	14'8"	13'2"	10'1"	9'4"	8'4"	14'2"	13'2"	11'7"	8'2"	7'6"	6'9"	11'3"	10'2"	8'8"
400S125-30	33	11'8"	10'9"	9'7"	16'5"	15'2"	13'7"	10'5"	9'7"	8'7"	14'8"	13'7"	12'0"	8'5"	7'9"	6'11"	11'8"	10'7"	9'2"
400S125-33	33	12'1"	11'2"	10'0"	17'1"	15'9"	14'1"	10'10"	10'0"	8'11"	15'3"	14'1"	12'5"	8'9"	8'1"	7'3"	12'2"	11'0"	9'7"
400S137-27	33	12'8"	11'9"	10'6"	17'7"	16'0"	13'11"	11'5"	10'6"	9'5"	15'4"	13'11"	12'2"	9'3"	8'7"	7'8"	11'10"	10'9"	9'5"e
400S137-30	33	13'2"	12'2"	10'10"	18'2"	16'6"	14'5"	11'9"	10'10"	9'9"	15'10"	14'5"	12'7"	9'7"	8'10"	7'11"	12'3"	11'1"	9'9"
400S137-33	33	13'8"	12'7"	11'3"	18'9"	17'0"	14'11"	12'2"	11'3"	10'1"	16'5"	14'11"	13'0"	9'10"	9'2"	8'2"	12'8"	11'6"	10'1"
400S162-33	33	15'6"	14'4"	12'10"	19'8"	17'10"	15'7"	13'10"	12'10"	11'6"	17'2"	15'7"	13'7"	11'3"	10'5"	9'4"	13'3"	12'0"	10'6"
550S125-27	33	12'5"	11'6"	10'5"	17'11"	16'7"	14'10"	11'2"	10'5"	9'4"	16'1"	14'10"	13'3"	9'2"	8'6"	7'7"	13'0"	11'11"	10'5"e
550S125-30	33	12'10"	11'10"	10'8"	18'5"	17'1"	15'4"	11'6"	10'8"	9'7"	16'7"	15'4"	13'9"	9'5"	8'9"	7'10"	13'5"	12'5"	11'0"e
550S125-33	33	13'3"	12'3"	11'0"	19'0"	17'7"	15'10"	11'11"	11'0"	9'11"	17'1"	15'10"	14'2"	9'8"	9'0"	8'1"	13'11"	12'10"	11'6"
550S137-27	33	14'1"	13'0"	11'9"	20'4"	18'10"	17'0"	12'8"	11'9"	10'7"	18'4"	17'0"	15'4"	10'4"	9'7"	8'8"	15'0"	13'10"e	12'1"e
550S137-30	33	14'6"	13'5"	12'1"	20'10"	19'4"	17'5"	13'0"	12'1"	10'10"	18'9"	17'5"	15'9"	10'8"	9'10"	8'11"	15'5"	14'4"	12'6"e
550S137-33	33	14'11"	13'10"	12'5"	21'5"	19'11"	17'11"	13'5"	12'5"	11'2"	19'4"	17'11"	16'2"	10'11"	10'2"	9'2"	15'10"	14'8"	12'11"
550S162-33	33	17'0"	15'9"	14'2"	24'5"	22'8"	20'0"	15'3"	14'2"	12'9"	22'0"	20'0"	17'5"	12'6"	11'7"	10'5"	17'0"	15'5"	13'6"e
600S125-27	33	12'9"e	11'10"e	10'8"e	18'5"e	17'0"e	15'2"e	11'6"e	10'8"e	9'7"e	16'5"e	15'2"e	13'7"e	9'5"e	8'9"e	7'10"e	13'3"e	12'3"e	10'9"e
600S125-30	33	13'2"	12'2"	10'11"	18'11"	17'7"	15'9"	11'10"	10'11"	9'10"	17'0"	15'9"	14'0"	9'8"	8'11"	8'1"	13'9"	12'8"	11'4"e
600S125-33	33	13'7"	12'7"	11'3"	19'6"	18'1"	16'3"	12'2"	11'3"	10'2"	17'6"	16'3"	14'7"	9'11"	9'2"	8'4"	14'3"	13'2"	11'9"
600S137-27	33	14'5"e	13'4"e	12'1"e	20'9"e	19'2"e	17'3"e	13'0"e	12'0"e	10'10"e	18'7"e	17'3"e	15'5"e	10'7"e	9'10"e	8'10"e	15'1"e	14'0"e	12'4"e
600S137-30	33	14'10"	13'9"	12'4"	21'5"	19'10"	17'9"	13'4"	12'4"	11'2"	19'2"	17'9"	15'11"	10'11"	10'2"	9'1"	15'7"	14'5"	12'10"e
600S137-33	33	15'3"	14'2"	12'9"	22'0"	20'5"	18'4"	13'9"	12'9"	11'5"	19'10"	18'4"	16'6"	11'3"	10'5"	9'5"	16'1"	14'11"	13'4"e
600S162-33	33	17'5"	16'1"	14'6"	25'1"	23'3"	21'0"	15'7"	14'6"	13'1"	22'7"	21'0"	18'8"	12'9"	11'10"	10'8"	18'2"	16'6"	14'5"e

Notes:

1. For unbraced sections, allowable moment based on AISI S100 section C3.1.2 with $K_yL_y = K_tL_t =$ listed span. For mid-span braced sections, allowable moment based on AISI S100 C3.1.2 with $K_yL_y = K_tL_t =$ (listed span)/2
2. Safety factors based on 0.9W per AISI S220-11, B1(a).
3. For spans listed with "e", web stiffeners are required at end reactions.
4. For distortional buckling allowable moment, $k_f = 0$.
5. Web crippling calculation based on bearing length = 1 inch.
6. Web crippling and shear capacity have not been reduced for punch-outs. If web punch-outs occur near supports members must be checked for reduced shear and web crippling in accordance with AISI S100.
7. Values are for simple span conditions.
8. Moment of inertia for deflection is calculated at the maximum service level stress for the span and load listed.
Note that this value may be higher than the effective I_{xx} listed in section property tables.



ALLOWABLE SCREW CAPACITIES**Allowable Screw Connection Capacity (lbs)**

Thickness (mils)	Design Thickness (inch)	Fy Yield (ksi)	Fu Tensile (ksi)	#6 Screw			#8 Screw			#10 Screw			#12 Screw			1/4" Screw		
				Pss = 643 lbs, Pts = 419 lbs			Pss = 1278 lbs, Pts = 586 lbs			Pss = 1644 lbs, Pts = 1158 lbs			Pss = 2330 lbs, Pts = 2325 lbs			Pss = 3048 lbs, Pts = 3201 lbs		
				0.138" dia, 0.272" head			0.164" dia, 0.272" head			0.190" dia, 0.340" head			0.216" dia, 0.340" head			0.250" dia, 0.409" head		
Shear	Pull-Out	Pull-Over	Shear	Pull-Out	Pull-Over	Shear	Pull-Out	Pull-Over	Shear	Pull-Out	Pull-Over	Shear	Pull-Out	Pull-Over	Shear	Pull-Out	Pull-Over	
18	0.0188	33	33	44	24	84	48	29	84	52	33	105	55	38	105	60	44	127
27	0.0283	33	33	82	37	127	89	43	127	96	50	159	102	57	159	110	66	191
30	0.0312	33	33	95	40	140	103	48	140	111	55	175	118	63	175	127	73	221
33	0.0346	33	45	151	61	140	164	72	195	177	84	265	188	95	265	203	110	318
43	0.0451	33	45	214	79	140	244	94	195	263	109	345	280	124	345	302	144	415
54	0.0566	50	65	214	140	140	426	171	195	534	198	386	569	225	625	613	261	752
68	0.0713	50	65	214	140	140	426	195	195	548	249	386	777	284	775	866	328	948
97	0.1017	50	65	214	140	140	426	195	195	548	356	386	777	405	775	1016	468	1067
118	0.1242	50	65	214	140	140	426	195	195	548	386	386	777	494	775	1016	572	1067

Notes

1. Capacities based on AISI S100 Section E4
2. Capacities are based on Allowable Strength Design (ASD) and include a Safety Factor of 3.0
3. Tabulated values assume 2 sheets of equal thickness are connected. When connecting materials of different steel thickness or tensile strengths, use the lowest values.
4. Where multiple fasteners are used, screws are assumed to have a center-to-center spacing of at least 3 times the nominal diameter (d).
5. Screws are assumed to have a center-of-screw to edge-of-steel dimension of at least 1.5 times the nominal diameter (d) of the screw.
6. Pull-out capacity is based on the lesser of pull-out capacity in sheet closest to screw tip or tension strength of screw.
7. Pull-over capacity is based on the lesser of pull-over capacity for sheet closest to screw header or tension strength of screw.
8. Values are for pure shear or tension loads. See AISI Section E4.5 for combined shear and pull-over.
9. Screw Shear (Pss), tension (Pts), diameter, and head diameter are from CFSEI Tech Note (F701-12).
10. Screw shear strength is the average value, and tension strength is the lowest value listed in CFSEI Tech Note (F701-12).

ALLOWABLE WELD CAPACITIES**Allowable Weld Capacity (lbs/in)**

Thickness (mils)	Design Thickness (inch)	Fy Yield (ksi)	Fu Tensile (ksi)	Fillet Welds		Flare Groove Welds	
				Longitudinal	Transverse	Longitudinal	Transverse
43	0.0451	33	45	499	864	544	663
54	0.0566	50	65	905	1566	985	1202
68	0.0713	50	65	1140	1972	1241	1514
97	0.1017	50	65	1269	1269	*	*

Notes

1. Capacities based on AISI S100 Section E2.4 for fillet welds and Section E2.5 for flare groove welds.
2. Capacities are based on Allowable Strength Design (ASD).
3. Tabulated values assume 2 sheets of equal thickness are connected. When connecting materials of different steel thickness or tensile strengths, use the lowest values.
4. Weld capacities are based on E60 electrodes. For material thinner than 68 mil, 0.030" to 0.035" diameter wire electrodes may provide best results.
5. Longitudinal capacity is considered to be loading in the direction of the length of the weld.
6. Transverse capacity is loading in perpendicular direction of the length of the weld.
7. For flare groove welds, the effective throat of weld is conservatively assumed to be less than 2t.
8. For longitudinal fillet welds, a minimum value of EQ E2.4-1, E2.4-2, and E2.4-4 was used.
9. For transverse fillet welds, a minimum value of EQ E2.4-3 and E2.4-4 was used.
10. For longitudinal flare groove welds, a minimum value of EQ E2.5-2 and E2.5-3 was used.

COLD-ROLLED CHANNEL (CRC) SECTION PROPERTIES

Section	Design Thickness (in)	Gross						Effective Properties 33 ksi			
		Area (in ²)	Weight (lb/ft)	I _x (in ⁴)	R _x (in)	I _y (in ⁴)	R _y (in)	I _x (in ⁴)	S _x (in ³)	Ma (in-k)	Va (lb)
CRC-075	0.0566	0.087	0.30	0.007	0.288	0.002	0.155	0.007	0.019	0.45	315
CRC-150	0.0566	0.129	0.44	0.039	0.547	0.003	0.144	0.039	0.052	1.22	840
CRC-200	0.0566	0.157	0.54	0.079	0.709	0.003	0.136	0.079	0.079	1.87	1190
CRC-250	0.0566	0.186	0.63	0.139	0.866	0.003	0.128	0.139	0.111	2.64	1540

ALLOWABLE CEILING SPANS**Cold-Rolled Channel (CRC)-L/240**

Section		4 psf Channel Spacing (in) o.c.					6 psf Channel Spacing (in) o.c.					13 psf Channel Spacing (in) o.c.					15 psf Channel Spacing (in) o.c.				
		24	36	48	60	72	24	36	48	60	72	24	36	48	60	72	24	36	48	60	72
CRC-075-33	Single	3'11"	3'5"	3'1"	2'10"	2'8"	3'5"	3'0"	2'8"	2'6"	2'4"	2'7"	2'4"	2'1"	1'11"	1'10"	2'6"	2'2"	2'0"	1'10"	1'9"
	Multiple	4'10"	4'2"	3'10"	3'7"	3'4"	4'2"	3'8"	3'4"	3'1"	2'11"	3'3"	2'10"	2'6"	2'3"	2'0"	3'1"	2'8"	2'4"	2'1"	1'11"
CRC-150-33	Single	5'9"	5'0"	4'7"	4'3"	4'0"	5'0"	4'5"	4'0"	3'9"	3'6"	3'11"	3'5"	3'1"	2'10"	2'8"	3'9"	3'3"	2'11"	2'8"	2'6"
	Multiple	7'4"	6'5"	5'10"	5'5"	5'1"	6'5"	5'7"	5'1"	4'9"	4'5"	5'0"	4'4"	3'11"	3'6"	3'2"	4'9"	4'1"	3'8"	3'3"	2'11"
CRC-200-33	Single	6'0"	5'3"	4'10"	4'6"	4'3"	5'3"	4'7"	4'3"	3'11"	3'8"	4'1"	3'7"	3'4"	3'1"	2'11"	3'11"	3'5"	3'2"	2'11"	2'9"
	Multiple	7'8"	6'9"	6'1"	5'8"	5'4"	6'9"	5'11"	5'4"	5'0"	4'8"	5'3"	4'7"	4'2"	3'11"	3'8"	5'0"	4'5"	4'0"	3'9"	3'5"
CRC-250-33	Single	6'3"	5'6"	5'0"	4'8"	4'5"	5'6"	4'10"	4'5"	4'1"	3'10"	4'3"	3'9"	3'5"	3'3"	3'0"	4'1"	3'7"	3'4"	3'1"	2'11"
	Multiple	8'0"	7'0"	6'4"	5'11"	5'7"	7'0"	6'2"	5'7"	5'2"	4'11"	5'5"	4'9"	4'4"	4'1"	3'10"	5'2"	4'7"	4'2"	3'11"	3'8"

Cold-Rolled Channel (CRC)-L/360

Section		4 psf Channel Spacing (in) o.c.					6 psf Channel Spacing (in) o.c.					13 psf Channel Spacing (in) o.c.					15 psf Channel Spacing (in) o.c.				
		24	36	48	60	72	24	36	48	60	72	24	36	48	60	72	24	36	48	60	72
CRC-075-33	Single	3'5"	3'0"	2'8"	2'6"	2'4"	3'0"	2'7"	2'4"	2'2"	2'1"	2'4"	2'0"	1'10"	1'8"	1'7"	2'2"	1'11"	1'9"	1'7"	1'6"
	Multiple	4'2"	3'8"	3'4"	3'1"	2'11"	3'8"	3'2"	2'11"	2'8"	2'7"	2'10"	2'6"	2'3"	2'1"	2'0"	2'8"	2'4"	2'2"	2'0"	1'10"
CRC-150-33	Single	5'9"	5'0"	4'7"	4'3"	4'0"	5'0"	4'5"	4'0"	3'9"	3'6"	3'11"	3'5"	3'1"	2'10"	2'8"	3'9"	3'3"	2'11"	2'8"	2'6"
	Multiple	7'4"	6'5"	5'10"	5'5"	5'1"	6'5"	5'7"	5'1"	4'9"	4'5"	5'0"	4'4"	3'11"	3'6"	3'2"	4'9"	4'1"	3'8"	3'3"	2'11"
CRC-200-33	Single	6'0"	5'3"	4'10"	4'6"	4'3"	5'3"	4'7"	4'3"	3'11"	3'8"	4'1"	3'7"	3'4"	3'1"	2'11"	3'11"	3'5"	3'2"	2'11"	2'9"
	Multiple	7'8"	6'9"	6'1"	5'8"	5'4"	6'9"	5'11"	5'4"	5'0"	4'8"	5'3"	4'7"	4'2"	3'11"	3'8"	5'0"	4'5"	4'0"	3'9"	3'5"
CRC-250-33	Single	6'3"	5'6"	5'0"	4'8"	4'5"	5'6"	4'10"	4'5"	4'1"	3'10"	4'3"	3'9"	3'5"	3'3"	3'0"	4'1"	3'7"	3'4"	3'1"	2'11"
	Multiple	8'0"	7'0"	6'4"	5'11"	5'7"	7'0"	6'2"	5'7"	5'2"	4'11"	5'5"	4'9"	4'4"	4'1"	3'10"	5'2"	4'7"	4'2"	3'11"	3'8"

Section	Design Thickness (in)		Gross Properties								
			F _y (ksi)	Web (in)	Area (in ²)	Weight (lb/ft)	I _{xx} (in ⁴)	S _x (in ³)	R _x (in)	I _{yy} (in ⁴)	R _y (in)
TB150-54	0.0566	0.0538	50	1.57	0.132	0.45	0.0460	0.0053	0.590	0.002	0.125

Section	Design Thickness (in)		Effective Properties							
			F _y (ksi)	Web (in)	Area (in ²)	Weight (lb/ft)	I _{xd} (in ⁴)	S _{xe} (in ³)	Ma-L (in-k)	Vax (lb)
TB150-54	0.0566	0.0538	50	1.57	0.132	0.45	0.0460	0.0053	1.586	1464

HAT-FURRING CHANNEL (DWFC) ALLOWABLE CEILING SPANS

Physical/Structural Properties for Hat Furring Channels (DWFC)

Section	Gross Properties								Effective Properties		
	Fy (ksi)	Design Thickness (in)	Area (in ²)	Weight (lb/ft)	Ix (in ⁴)	Rx (in)	Iy (in ⁴)	Ry (in)	Ix (in ⁴)	Sx (in ³)	Ma (Ft-lb)
DWFC088-18	33	0.0188	0.0702	0.239	0.0089	0.3565	0.0354	0.7101	0.0086	0.0160	26.4
DWFC088-30	33	0.0312	0.1149	0.391	0.0143	0.3527	0.0580	0.7105	0.0143	0.0307	50.5
DWFC088-43	33	0.0451	0.1617	0.550	0.0196	0.3481	0.0817	0.7108	0.0196	0.0420	69.2
DWFC088-54	50	0.0566	0.1967	0.669	0.0234	0.3448	0.0994	0.7109	0.0234	0.0501	124.9
DWFC150-18	33	0.0188	0.0939	0.320	0.0311	0.5752	0.0467	0.7052	0.0299	0.0344	56.6
DWFC150-30	33	0.0312	0.1543	0.525	0.0503	0.5710	0.0767	0.7050	0.0503	0.0639	105.3
DWFC150-43	33	0.0451	0.2188	0.745	0.0699	0.5654	0.1087	0.7048	0.0699	0.0888	146.3
DWFC150-54	50	0.0566	0.2686	0.914	0.0844	0.5606	0.1335	0.7050	0.0844	0.1071	267.2

- Notes:
1. Properties based on the AISI S100-2012. Safety factor NOT adjusted for AISI S220-11 for Ma determination
 2. Design thickness used for determination of properties. Minimum delivered thickness must be no less than 95% of design thickness.
 3. For deflection calculations, use effective Ixx.
 4. Effective properties are given as the minimum value for positive or negative bending.

Hat Furring Channel (DWFC) Allowable Ceiling Spans - L/240

Section	Fy (ksi)	Spans	4 psf Spacing (in) oc			Uniform Load 6 psf Spacing (in) oc			13 psf Spacing (in) oc		
			12	16	24	12	16	24	12	16	24
DWFC088-18	33	Single	5'2"	4'8"	4'1"	4'6"	4'1"	3'7"	3'6"	3'2"	2'9"
		Multiple	6'5"	5'10"	5'1"	5'7"	5'1"	4'4"	4'2"	3'8"	2'11"
DWFC088-30	33	Single	6'1"	5'7"	4'10"	5'4"	4'10"	4'3"	4'1"	3'9"	3'3"
		Multiple	7'7"	6'11"	6'0"	6'7"	6'0"	5'3"	5'1"	4'8"	4'1"
DWFC088-43	33	Single	6'10"	6'2"	5'5"	5'11"	5'5"	4'8"	4'7"	4'2"	3'8"
		Multiple	8'5"	7'8"	6'8"	7'4"	6'8"	5'10"	5'8"	5'2"	4'6"
DWFC088-54	50	Single	7'3"	6'7"	5'9"	6'4"	5'9"	5'0"	4'10"	4'5"	3'10"
		Multiple	8'11"	8'1"	7'1"	7'10"	7'1"	6'2"	6'0"	5'6"	4'9"
DWFC150-18	33	Single	7'10"	7'1"	6'3"	6'10"	6'3"	5'5"	5'3"	4'10"	4'2"
		Multiple	9'9"	8'10"	7'8"	8'6"	7'8"	6'3"	5'11"	5'0"	3'11"
DWFC150-18	33	Single	9'4"	8'6"	7'5"	8'2"	7'5"	6'6"	6'3"	5'9"	5'0"
		Multiple	11'7"	10'6"	9'2"	10'1"	9'2"	8'0"	7'9"	7'1"	5'11"
DWFC150-43	33	Single	10'5"	9'6"	8'3"	9'1"	8'3"	7'3"	7'0"	6'5"	5'7"
		Multiple	12'11"	11'9"	10'3"	11'3"	10'3"	8'11"	8'8"	7'11"	6'11"
DWFC150-54	50	Single	11'1"	10'1"	8'10"	9'8"	8'10"	7'8"	7'6"	6'10"	5'11"
		Multiple	13'9"	12'6"	10'11"	12'0"	10'11"	9'6"	9'3"	8'5"	7'4"

- Notes:
1. Allowable spans include 0.9 multiplier on safety factor, W, per AISI S220-11
 2. Single spans taken as the minimum span based on moment, shear, web crippling or deflection
 3. Multiple spans indicate two or more equal, continuous spans with span length measured support to support.
 4. Multiple spans taken as the minimum span based on moment, shear, web crippling, deflection combined bending and shear or combined and web crippling
 5. Web crippling values based on 1" bearing at end and interior supports.



HAT-FURRING CHANNEL (DWFC) ALLOWABLE CEILING SPANS

Hat Furring Channel (DWFC) Allowable Ceiling Spans - L/360

Section	F _y (ksi)	Spans	4 psf Spacing (in) oc			Uniform Load 6 psf Spacing (in) oc			13 psf Spacing (in) oc		
			12	16	24	12	16	24	12	16	24
DWFC088-18	33	Single	4'6"	4'1"	3'7"	3'11"	3'7"	3'1"	3'0"	2'9"	2'5"
		Multiple	5'7"	5'1"	4'5"	4'10"	4'5"	3'10"	3'9"	3'5"	2'11"
DWFC088-30	33	Single	5'4"	4'10"	4'3"	4'8"	4'3"	3'8"	3'7"	3'3"	2'10"
		Multiple	6'7"	6'0"	5'3"	5'9"	5'3"	4'7"	4'5"	4'1"	3'6"
DWFC088-43	33	Single	5'11"	5'5"	4'8"	5'2"	4'8"	4'1"	4'0"	3'8"	3'2"
		Multiple	7'4"	6'8"	5'10"	6'5"	5'10"	5'1"	4'11"	4'6"	3'11"
DWFC088-43	50	Single	6'4"	5'9"	5'0"	5'6"	5'0"	4'4"	4'3"	3'10"	3'4"
		Multiple	7'10"	7'1"	6'2"	6'10"	6'2"	5'5"	5'3"	4'9"	4'2"
DWFC150-18	33	Single	6'10"	6'3"	5'5"	6'0"	5'5"	4'9"	4'7"	4'2"	3'8"
		Multiple	8'6"	7'8"	6'9"	7'5"	6'9"	5'10"	5'9"	5'0"	3'11"
DWFC150-30	33	Single	8'2"	7'5"	6'6"	7'1"	6'6"	5'8"	5'6"	5'0"	4'4"
		Multiple	10'1"	9'2"	8'0"	8'10"	8'0"	7'0"	6'10"	6'2"	5'5"
DWFC150-43	33	Single	9'1"	8'3"	7'3"	7'11"	7'3"	6'4"	6'2"	5'7"	4'10"
		Multiple	11'3"	10'3"	8'11"	9'10"	8'11"	7'10"	7'7"	6'11"	6'0"
DWFC150-54	50	Single	9'8"	8'10"	7'8"	8'6"	7'8"	6'8"	6'6"	5'11"	5'2"
		Multiple	12'0"	10'11"	9'6"	10'6"	9'6"	8'4"	8'1"	7'4"	6'5"

Notes: 1. Allowable spans include 0.9 multiplier on safety factor, W, per AISI S220-11

2. Single spans taken as the minimum span based on moment, shear, web crippling or deflection

3. Multiple spans indicate two or more equal, continuous spans with span length measured support to support.

4. Multiple spans taken as the minimum span based on moment, shear, web crippling, deflection combined bending and shear or combined and web crippling

5. Web crippling values based on 1" bearing at end and interior supports.

T-BRACE BRIDGING

INTRODUCING T-BRACE, A NEW PRODUCT INNOVATION FROM TELLING INDUSTRIES

T-Brace is used as mechanical bridging for studs. Typically, U-Channel or CRC, is attached to studs via clips or a weld to eliminate stud rotation and bending under wind or axial loads. 1-1/2" T-Brace is passed through the stud knockout and snapped securely into place with Telling's patented technology saving valuable time and money.

T-Brace features an innovative, highly engineered design that securely locks the T-Brace into the stud slot hole without the need for clips or welding for most non-structural applications.

Patent 10,309,107 | 10,590,647



Features:

- Made of Galvanized Steel in 2 gauges: 16ga and 20ga (30mil)
- Highly Engineered for Secure Fit in Stud Knockout
- T-Brace Locks into the Stud without Clips or Welding
- Notches every 4" to accommodate 12", 16", 24" OC Stud Spacing

Benefits:

- Reduces Installation Time
- 10% Savings on Material and Labor Costs
- No Clips or Welding Required
- Easy Installation due to patented design

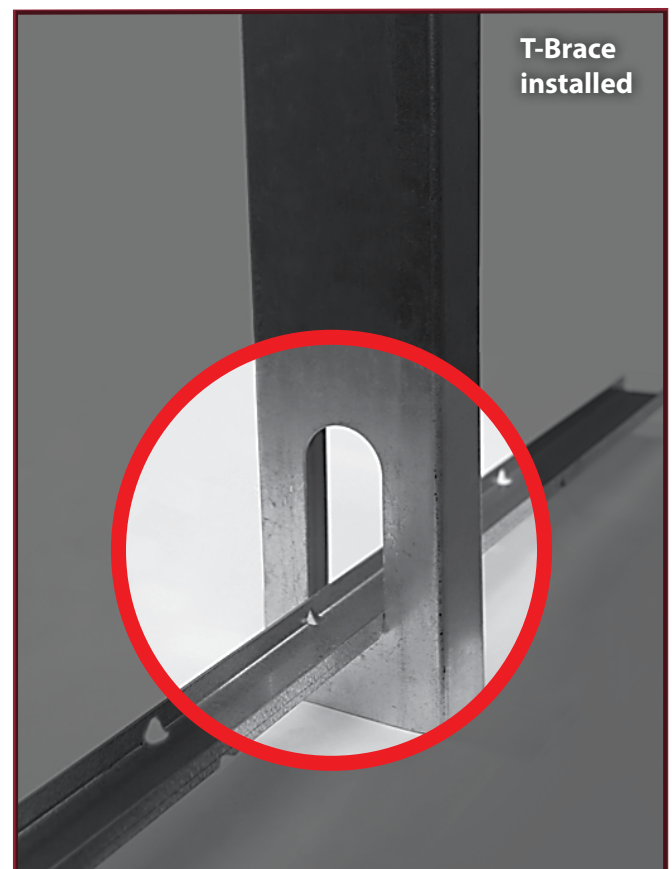
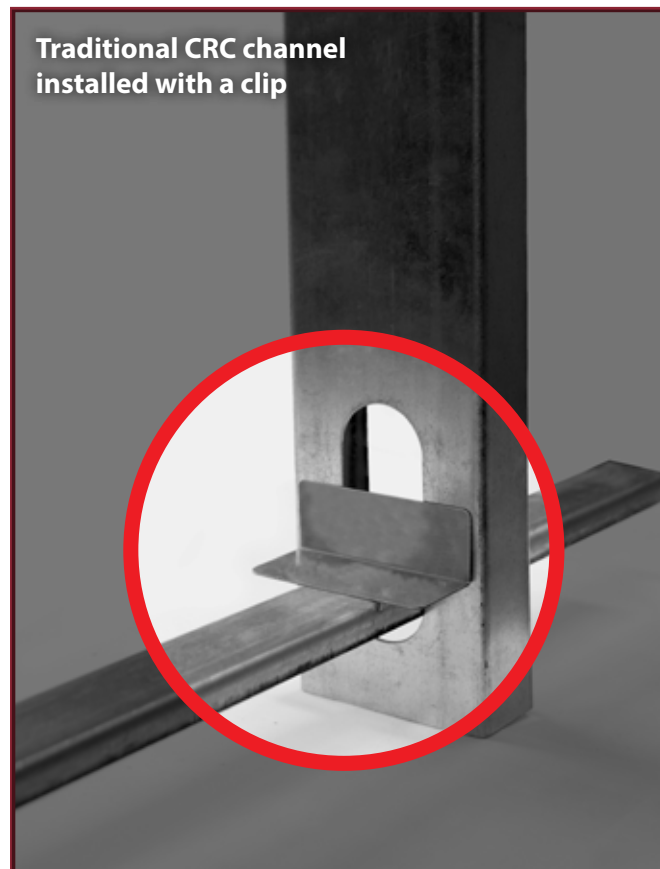

SEE
THE
VIDEO

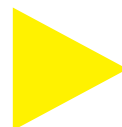

www.buildstrong.com

For more information, please contact Telling Engineering Consultants at 866-372-6384. This technical information reflects the most current information available and supersedes any and all previous publications Telling Industries, LLC 2020

T-BRACE BRIDGING

Product Data:

- Available in galvanized steel meeting ASTM A-1003 or hot-dipped galvanized steel meeting ASTM A-653, G60.
- Lengths: 52" stock length. (Other lengths available in 4" increments).
- Patent # 10,309,107 (T-Brace), Patent # 10,508,446 (T-Bridge)

Uses:

- Bridging, (lateral support) in walls carrying axial and/or wind loads.
- Clips are not required for many non-load bearing applications.

Section	Design Thickness (in)		Gross Properties								
			Fy (ksi)	Web (in)	Area (in ²)	Weight (lb/ft)	Ixx (in ⁴)	Sx (in ³)	Rx (in)	Iyy (in ⁴)	Ry (in)
TB150-54	0.0566	0.0538	50	1.57	0.132	0.45	0.0460	0.0053	0.590	0.002	0.125
TB150-30	0.0296	0.0312	50	1.57	0.074	0.25	0.0266	0.0308	0.599	0.001	0.128

Section	Design Thickness (in)		Effective Properties							
			Fy (ksi)	Web (in)	Area (in ²)	Weight (lb/ft)	Ixd (in ⁴)	Sxe (in ³)	Ma-L (in-k)	Vax (lb)
TB150-54	0.0566	0.0538	50	1.57	0.132	0.45	0.0460	0.0053	1.586	1464
TB150-30	0.0296	0.0312	50	1.57	0.074	0.25	0.0259	0.0299	0.894	780

Product Details

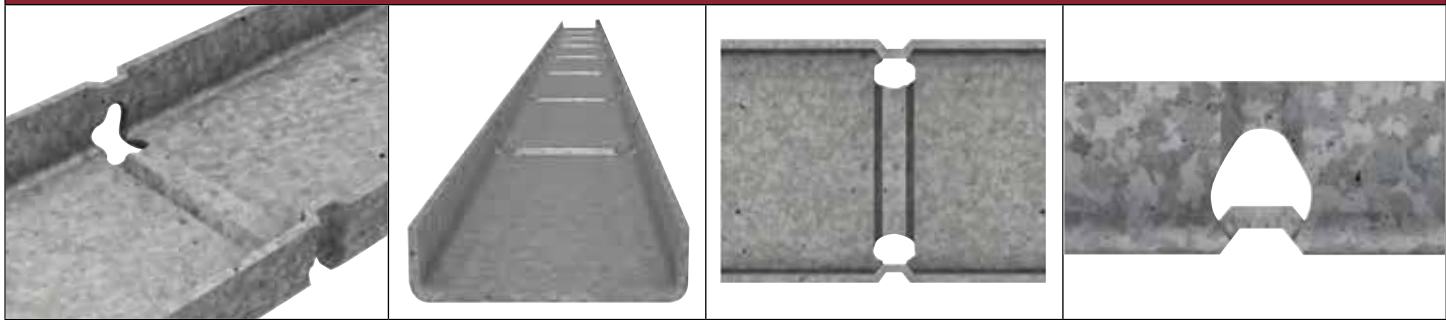

T-Brace with self nesting geometry to fit one part inside of another and secured with a screw.
 T-Brace locking features spaced every 4" to accommodate 12", 16" and 24" on center stud spacing.

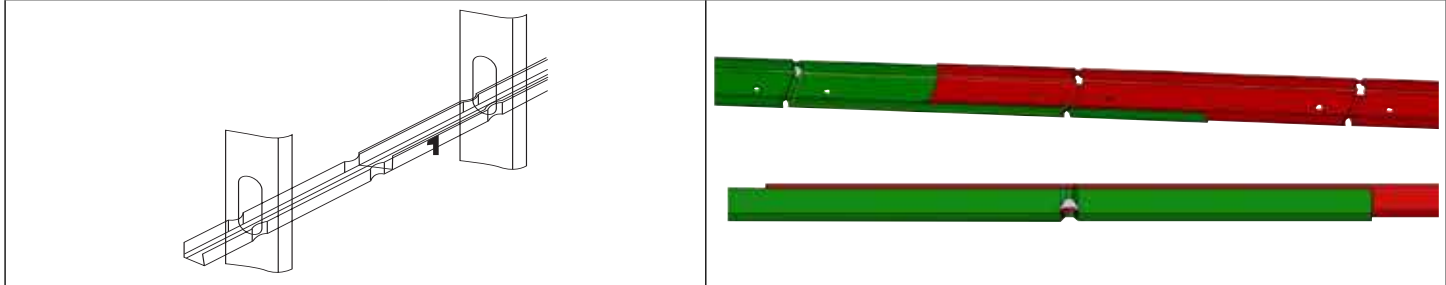

Accessories

T-Bridge Clip (Terminating)

T-Bridge Clip (Joining)

US Patent # 10,508,446



T-Bridge clips are compatible with Telling's Standard CRC Bracing & T-Brace.

TRUE-RULE TECHNOLOGY

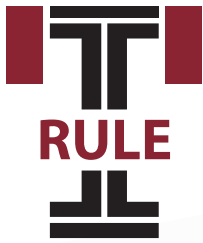

A PRODUCT INNOVATION FROM TELLING INDUSTRIES

US PATENT 11,002,011

Market Need:

- Some metal framing must be custom cut to length at the job site.
- The inaccuracy of stretching a tape measure across a metal framing component, marking it, then field cutting or track and stud layout can lead to undesirable length variation and increased install time.
- If the length variation is too excessive, the field cut metal framing components may need to be scrapped and new pieces re-cut, resulting in higher material costs.

Solution:

- Telling has a patent pending invention to add ruler marking to metal framing stud & track to simplify field cutting and wall layouts.
- The ruler markings will be permanently applied via etching/embossing.

Product Info:

- Readily available on 30mil & 33mil traditional drywall studs at no upcharge.
- The marking will be in 1/4", 1/2" & 1" increments.
- Available upon request for 18ga & 16ga studs for a modest upcharge.
- Standard: 2ft of etched ruler marking.
- Upon request: etch entire length of stud for a modest upcharge.
- Track is coming soon!

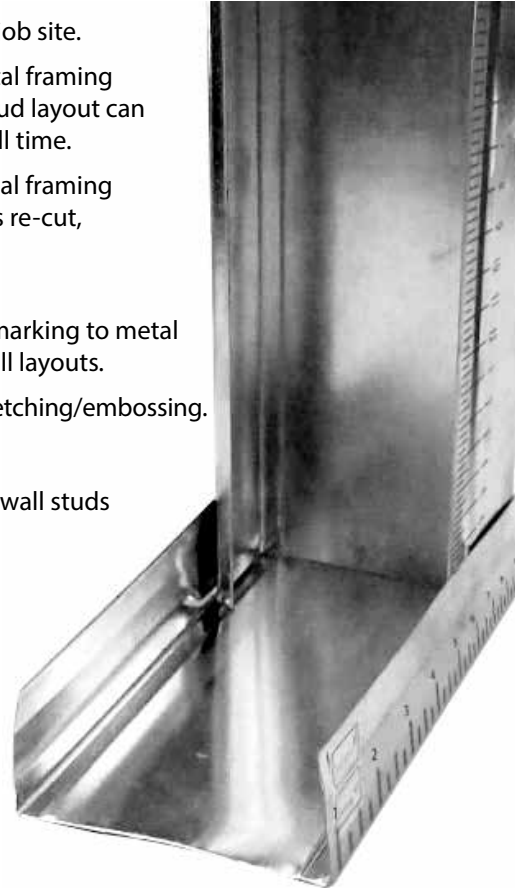

NO MORE MEASURING TAPE! TRUE-RULE TECHNOLOGY MAKES CUTTING STUD AND TRACK A BREEZE!



www.buildstrong.com

For more information, please contact Telling Engineering Consultants at 866-372-6384. This technical information reflects the most current information available and supersedes any and all previous publications Telling Industries, LLC 2020

THE LEADER IN METAL FRAMING INNOVATION

INNOVATIVE, RESPONSIVE SOLUTIONS FOR ALL YOUR METAL FRAMING NEEDS

TRUE-ACTION SLOTTED TRACK

TRUE BRACE

VERSADRY DRY WALL TRACK

TRUEBEAD™

CLIP ANGLES With CUSTOM HOLES

SUPREME™ STEEL FRAMING SYSTEM

TRUE FLATSTRAP

TRIFLEX™ HEADER SYSTEM

TELLING

PakChan

TRUE-BRIDGE

TRUE-Rule TECHNOLOGY

MADE IN THE USA

TELLING INDUSTRIES

www.BuildStrong.com | 866-372-6384





TELLING ENGINEERING CONSULTANTS

The TELLING® Engineering Consultant [TEC] group provides quoted professional fully licensed full-service engineering and technical consultation to contractors, architects and structural engineers nationwide.

The Telling® Engineering Consultant [TEC] group offers quoted services including:

- Shop drawings and calculations for curtain (non-load bearing) and full load-bearing designs
- Preliminary sizing
- Pre-bid engineering pricing
- FREE technical assistance including LEED compliance with Telling's products.

ENGINEERING AND DESIGN SERVICES (QUOTED) & TECHNICAL SERVICES (FREE)

technical@tellingindustries.com

1-866-372-6384

440-478-8625 (direct)

ENGINEERING - RECOMMENDED FIRMS

**PREFERRED
ENGINEERING
FIRM**

RAZ TECH, INC.

Web: www.raztechinc.com

Email: rzadeh@raztechinc.com

Office: 678.878.3748

Cell: 404.665.7506

Address: RAZ Tech, Inc.

419 E. Crossville Road, Suite 108
Roswell, GA 30075

DEVCO ENGINEERING INC.

Web: www.devcoengineering.com

E-Mail: administrator@devcoengineering.com

Phone: 541.757.8991

Fax: 541.757.9885

Address: DEVCO Engineering, Inc.

245 NE Conifer, P.O. Box 1211

Corvallis, OR 97339

EXCEL ENGINEERING

Web: www.excelengineer.com

E-Mail: info@excelengineer.com

Phone: 920.926.9800

Fax: 920.926.9801

Address: 100 Camelot Drive

Fond du Lac, WI 54935



www.tellingindustries.com

LOCATIONS

CORPORATE HEADQUARTERS: 4420 SHERWIN ROAD WILLOUGHBY, OH 44094

E-MAIL: SALES.CORP@TELLINGINDUSTRIES.COM | **PHONE:** 440-974-3370 | **TOLL FREE:** 866-372-6384 | **FAX:** 440-974-3408

MIDWEST FACILITY: 2105 LARRICK ROAD CAMBRIDGE, OH 43725

E-MAIL: SALES.CORP@TELLINGINDUSTRIES.COM | **PHONE:** 740-435-8900 | **TOLL FREE:** 866-357-8837 | **FAX:** 740-435-8915

NORTHEAST FACILITY: 1050 KENNEDY ROAD WINDSOR, CT 06095

E-MAIL: SALES.CORP@TELLINGINDUSTRIES.COM | **PHONE:** 860-731-7975 | **TOLL FREE:** 866-372-6384 | **FAX:** 860-731-7976

MIDSOUTH FACILITY: 1400 SOUTHWIRE DRIVE OSCEOLA, AR 72370

E-MAIL: SALES.CORP@TELLINGINDUSTRIES.COM | **PHONE:** 870-563-6065 | **TOLL FREE:** 888-711-3124

SOUTHEAST FACILITY: 1200 W MARTIN LUTHER KING BLVD, PLANT CITY, FL 33563

E-MAIL: SALES.CORP@TELLINGINDUSTRIES.COM | **PHONE:** 440-974-3370 | **TOLL FREE:** 866- FRAME-TI (372-6384) | **FAX:** 440-974-3408