



**SLOTTED**



**THE LEADER IN METAL  
FRAMING INNOVATION**



**HEAD OF WALL DEFLECTION SYSTEM**

## WHAT IS TRUE-ACTION™ SLOTTED TRACK - HEAD OF WALL DEFLECTION SYSTEM?

True-Action™ Slotted Track is the industry preferred system for achieving head-of-wall deflection and fire resistance for interior and exterior walls. It meets movement and cycling requirements for ANSI/UL 2079 and is UL Classified for 1, 2, 3, and 4 hour fire-resistant ratings in head-of-wall fire-rated joint systems.

### BENEFITS

- Fire-rated deflection system
- UL Classified in over 80 approved fire-rated systems
- Standard Slotted Track allows vertical movement
- Custom web, leg and lengths are available (Custom slot sizes are not available)
- Positive attachment provided for wall strength
- Absorbs head-of-wall and floor extension or compression movement
- Integrated with traditional wall systems
- Easy installation reduces labor costs



Telling Slotted Track is listed in many gypsum based UL Wall Designs utilizing 0.030" material or thicker for Studs with a web ranging from 2.5" to 8.0".

## 2.5" SLOTTED TRACK

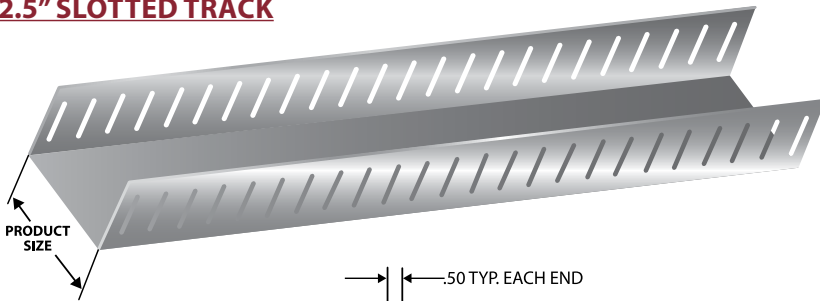

**30 EQD SLOTTED TRACK**  
**Another Innovation**  
**From Telling Industries!**

**PRODUCT SIZES:**  
 MAX WEB: 8"  
 FLANGE: 2.5"

**MATERIAL GAUGES:**  
 .0235" MINIMUM  
 .071" MAXIMUM

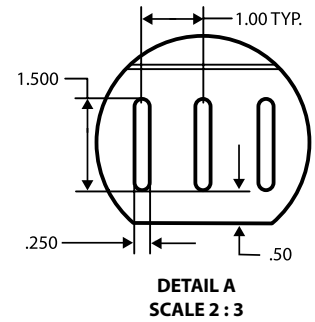
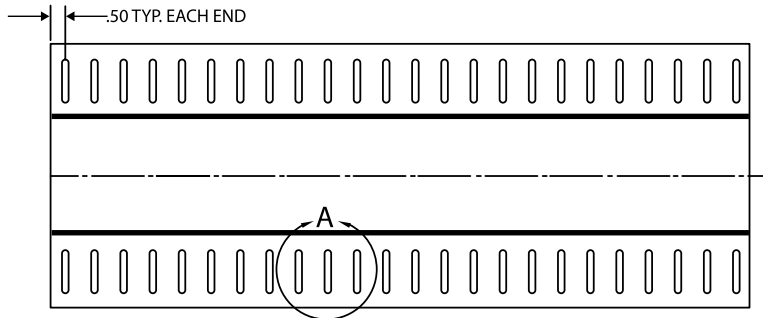

## 3" SLOTTED TRACK

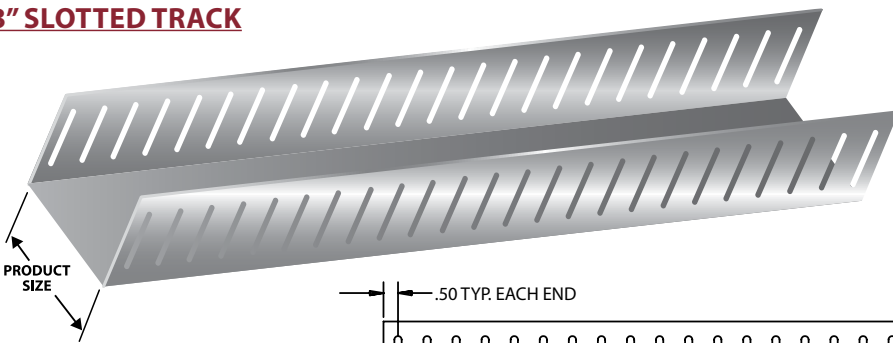

**PRODUCT SIZES:**  
 MAX WEB: 8"  
 FLANGE: 3"

**MATERIAL GAUGES:**  
 .030" MINIMUM  
 .054" MAXIMUM

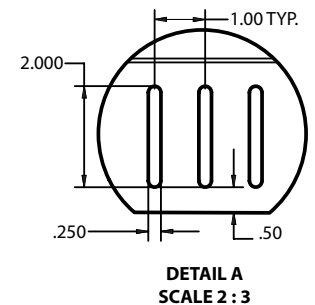
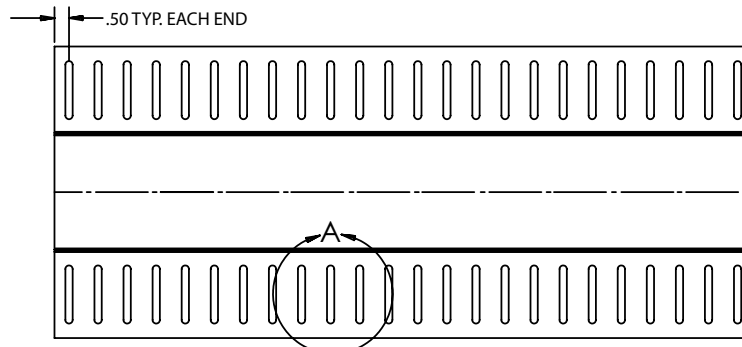

**INNOVATION, SERVICE, QUALITY**



- Telling Slotted Track can be substituted in place of any UL Wall Design utilizing 0.030" or thicker Slotted Track
- Telling Slotted Track can be used for Studs with a web of 2.5" to 8.0". Telling Slotted Track can not be used in a UL firewall design for walls constructed with 1-5/8" web studs, nor 10", 12", 14", 16" web studs
- The Wall design must use Gypsum and not alternative wallboard materials

## UL RATED DESIGNS

### TRUE-ACTION™ SLOTTED TRACK FRAMING MEMBERS FOR USE IN JOINT SYSTEMS NUMBERS

HW-D-0003	HW-D-0016	HW-D-0020	HW-D-0021	HW-D-0024	HW-D-0025	HW-D-0029	HW-D-0031
HW-D-0034	HW-D-0036	HW-D-0042	HW-D-0043	HW-D-0044	HW-D-0045	HW-D-0046	HW-D-0047
HW-D-0048	HW-D-0049	HW-D-0054	HW-D-0062	HW-D-0063	HW-D-0067	HW-D-0068	HW-D-0069
HW-D-0071	HW-D-0072	HW-D-0073	HW-D-0076	HW-D-0077	HW-D-0082	HW-D-0083	HW-D-0084
HW-D-0085	HW-D-0087	HW-D-0088	HW-D-0089	HW-D-0091	HW-D-0099	HW-D-0101	HW-D-0102
HW-D-0106	HW-D-0107	HW-D-0108	HW-D-0111	HW-D-0134	HW-D-0136	HW-D-0137	HW-D-0144
HW-D-0146	HW-D-0152	HW-D-0154	HW-D-0160	HW-D-0162	HW-D-0167	HW-D-0170	HW-D-0173
HW-D-0183	HW-D-0184	HW-D-0185	HW-D-0186	HW-D-0190	HW-D-0193	HW-D-0194	HW-D-0195
HW-D-0205	HW-D-0210	HW-D-0217	HW-D-0218	HW-D-0241	HW-D-0242	HW-D-0243	HW-D-0246
HW-D-0259	HW-D-0260	HW-D-0263	HW-D-0265	HW-D-0271	HW-D-0272	HW-D-0275	HW-D-0277
HW-D-0278	HW-D-0293	HW-D-0313	HW-D-0322	HW-D-0341	HW-D-0420	HW-D-0421	HW-D-0453
HW-D-0455	HW-D-0461	HW-D-0462	HW-D-0463	HW-D-0467	HW-D-0468	HW-D-0475	HW-D-0476
HW-D-0477	HW-D-0480	HW-D-0485	HW-D-0486	HW-D-0517	HW-D-0532	HW-D-0541	HW-D-0542
HW-D-0548	HW-D-0549	HW-D-0564	HW-D-0569	HW-D-0570	HW-D-0571	HW-D-0572	

Note: Details of UL Rated Designs available at [www.BuildStrong.com](http://www.BuildStrong.com).

## ALLOWABLE WALL HEIGHTS (ft)

Gauge		Strength	Allowable Reaction (lb/stud)	Lateral Pressure (PSF)											
Mill Thickness (mils)	Design Thickness (in)	Fy (ksi)		5 PSF			10 PSF			20 PSF			30 PSF		
				Stud Spacing (in)			Stud Spacing (in)			Stud Spacing (in)			Stud Spacing (in)		
				12	16	24	12	16	24	12	16	24	12	16	24
30EQD	0.0235"	57	55	22.0	16.5	11.0	11.0	8.3	NA	NA	NA	NA	NA	NA	NA
33	.0346	33	98	39.2	29.4	19.6	19.6	14.7	9.8	9.8	7.35	4.9	6.533	4.9	3.267
43	.0451	33	172	68.8	51.6	34.4	34.4	25.8	17.2	17.2	12.9	8.6	11.47	8.6	5.733
54	.0566	50	423	169.2	126.9	84.6	84.6	63.45	42.3	42.3	31.73	21.15	28.2	21.15	14.1
68	.0713	50	626	250.4	187.8	125.2	125.2	93.9	62.6	62.6	46.95	31.3	41.73	31.3	20.87

- Note:
1. Based on testing and analysis by Structural Testing and Research (STaR) Report No. 3160903 dated March 29, 2010 (Amended May 19, 2010).
  2. Testing based on maximum 7/8" gap between end of stud and track web.
  3. Testing based on #8 screws each leg for 33-mil track, #10 each leg for 43, 54 and 68-mil track. All screws were pan head, 0.43 inch head diameter.
  4. Loads have not been modified for duration of load.

## TELLING 2.5" SLOTTED TRACK SECTION PROPERTIES

Section	Design Thickness (in)	Fy (ksi)	Gross Properties <sup>1</sup>							Effective Properties <sup>4,5</sup>		
			Area (in <sup>2</sup> )	Net Area <sub>2</sub> (in <sup>2</sup> )	Wt. <sup>3</sup> (lb/ft)	I <sub>xx</sub> (in <sup>4</sup> )	R <sub>x</sub> (in)	I <sub>yy</sub> (in <sup>4</sup> )	R <sub>y</sub> (in)	I <sub>yy?</sub> (in <sup>4</sup> )	S <sub>yy</sub> (in <sup>3</sup> )	M <sub>ax,y</sub> (in-k)
250TAT250-30EQD	0.0235"	57	0.1763	0.0888	0.5998	0.1212	0.8292	0.229	1.1397	0.083	0.046	
250TAT250-30	0.0312	33	0.234	0.140	0.86	0.160	0.826	0.306	1.143	0.116	0.079	1.55
250TAT250-33	0.0346	33	0.259	0.156	0.88	0.178	0.827	0.339	1.144	0.129	0.087	1.72
250TAT250-43	0.0451	33	0.338	0.203	1.15	0.230	0.826	0.443	1.146	0.168	0.113	2.23
250TAT250-54	0.0566	50	0.424	0.254	1.44	0.287	0.824	0.565	1.155	0.213	0.141	4.22
250TAT250-68	0.0713	50	0.534	0.32	1.82	0.360	0.821	0.728	1.168	0.273	0.177	5.29
350TAT250-33	0.0346	33	0.294	0.19	1	0.198	0.821	0.687	1.528	0.286	0.138	2.73
350TAT250-43	0.0451	33	0.383	0.248	1.3	0.257	0.819	0.896	1.53	0.373	0.185	3.66
350TAT250-54	0.0566	50	0.48	0.311	1.63	0.321	0.817	1.137	1.538	0.471	0.232	6.93
350TAT250-68	0.0713	50	0.605	0.391	2.06	0.401	0.814	1.454	1.55	0.598	0.29	8.69
362TAT250-30EQD	0.0235"	57	0.2027	0.1152	0.6898	0.1369	0.8217	0.5006	1.5715	0.19	0.069	
362TAT250-30	0.0312	33	0.269	0.175	0.92	0.181	0.820	0.667	1.575	0.281	0.126	2.49
362TAT250-33	0.0346	33	0.298	0.194	1.01	0.200	0.820	0.740	1.575	0.312	0.144	2.85
362TAT250-43	0.0451	33	0.389	0.253	1.32	0.260	0.818	0.966	1.577	0.406	0.195	3.86
362TAT250-54	0.0566	50	0.487	0.318	1.66	0.324	0.816	1.224	1.585	0.512	0.244	7.32
362TAT250-68	0.0713	50	0.614	0.4	2.09	0.406	0.813	1.565	1.597	0.65	0.306	9.17
400TAT250-30EQD	0.0235"	57	0.2115	0.1240	0.7197	0.1412	0.8171	0.6188	1.7105	0.236	0.077	
400TAT250-30	0.0312	33	0.281	0.187	0.96	0.187	0.816	0.824	1.713	0.354	0.142	2.80
400TAT250-33	0.0346	33	0.311	0.207	1.06	0.207	0.815	0.914	1.714	0.396	0.162	3.21
400TAT250-43	0.0451	33	0.405	0.27	1.38	0.268	0.813	1.193	1.715	0.516	0.227	4.49
400TAT250-54	0.0566	50	0.509	0.339	1.73	0.335	0.811	1.511	1.723	0.65	0.284	8.51
400TAT250-68	0.0713	50	0.641	0.427	2.18	0.418	0.808	1.928	1.735	0.825	0.356	10.67
550TAT250-33	0.0346	33	0.363	0.259	1.24	0.228	0.792	1.839	2.251	0.837	0.236	4.66
550TAT250-43	0.0451	33	0.473	0.338	1.61	0.295	0.79	2.399	2.252	1.142	0.34	6.72
550TAT250-54	0.0566	50	0.594	0.424	2.02	0.368	0.788	3.029	2.259	1.436	0.43	12.87
550TAT250-68	0.0713	50	0.748	0.534	2.54	0.46	0.785	3.849	2.269	1.817	0.584	17.48
600TAT250-30EQD	0.0235"	57	0.2585	0.1710	0.8797	0.1594	0.7853	1.5157	2.4214	0.579	0.118	
600TAT250-30	0.0312	33	0.343	0.250	1.17	0.211	0.784	2.016	2.424	0.904	0.224	4.44
600TAT250-33	0.0346	33	0.380	0.277	1.29	0.233	0.783	2.236	2.424	1.026	0.26	5.14
600TAT250-43	0.0451	33	0.496	0.36	1.69	0.303	0.781	2.916	2.425	1.407	0.378	7.47
600TAT250-54	0.0566	50	0.622	0.452	2.12	0.377	0.779	3.678	2.432	1.777	0.478	14.31
600TAT250-68	0.0713	50	0.783	0.569	2.67	0.472	0.776	4.67	2.442	2.266	0.655	19.61
800TAT250-30	0.0312	33	0.406	0.312	1.38	0.227	0.749	3.894	3.099	1.752	0.307	6.07
800TAT250-33	0.0346	33	0.450	0.346	1.53	0.252	0.748	4.318	3.099	2.003	0.358	7.07
800TAT250-43	0.0451	33	0.586	0.451	1.99	0.326	0.746	5.629	3.1	2.801	0.53	10.47
800TAT250-54	0.0566	50	0.735	0.565	2.5	0.407	0.744	7.09	3.106	3.54	0.671	20.1
800TAT250-68	0.0713	50	0.926	0.712	3.15	0.509	0.741	8.978	3.114	4.698	0.942	28.21

**Notes:** 1. Gross properties are based on the full section away from flange slots. 2. Net area is based on the section through the flange slots. 3. Weight is nominal weight of the gross section, not reduced for flange slots. 4. Effective properties are calculated in accordance with the 2016 NASPEC with 2018 Supplement (AISI S100-16/S1-18 and AISI S100-12). For effective flange widths, the compression flange (before local buckling) is taken as the portion of the flange between the web and the slot (the slot and any steel beyond the slot is considered absent). The tension flange is taken as the net flange at the slots. 5. Cold-work of forming has not been considered for effective properties. 6. Web width-to-thickness ratio exceeds 200. Web stiffeners are required at points of concentrated loads or reactions. 7. IBC 2006, 2009, 2012, 2015 and 2018 compliant.

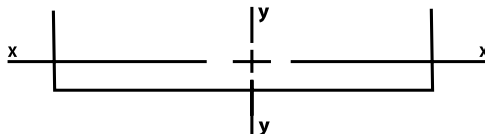

**INNOVATION, SERVICE, QUALITY**

[www.tellingindustries.com](http://www.tellingindustries.com)

**TELLING 3.0" SLOTTED TRACK SECTION PROPERTIES**

Section	Design Thickness (in)	Fy (ksi)	Gross Properties <sup>1</sup>							Effective Properties <sup>4,5</sup>		
			Area (in <sup>2</sup> )	Net Area <sup>2</sup> (in <sup>2</sup> )	Wt. <sup>3</sup> (lb/ft)	Ix (in <sup>4</sup> )	Rx (in)	Iy (in <sup>4</sup> )	Ry (in)	Iy (in <sup>4</sup> )	Sy (in <sup>3</sup> )	M <sub>ax-y</sub> (in-k)
250TAT300-30	0.0312	33	0.265	0.140	0.902	0.262	0.993	0.359	1.163	0.188	0.104	1.711
250TAT300-33	0.0346	33	0.294	0.156	1.00	0.290	0.993	0.398	1.164	0.215	0.120	1.974
250TAT300-43	0.0451	33	0.383	0.203	1.30	0.376	0.991	0.521	1.166	0.306	0.174	2.874
250TAT300-54	0.0566	50	0.480	0.254	1.63	0.470	0.989	0.664	1.176	0.397	0.224	6.712
250TAT300-68*	0.0713	50	0.605	0.320	2.06	0.589	0.987	0.856	1.190	0.559	0.321	9.616
350TAT300-33	0.0346	33	0.329	0.190	1.12	0.324	0.992	0.799	1.560	0.457	0.190	3.139
350TAT300-43	0.0451	33	0.428	0.248	1.46	0.420	0.991	1.044	1.562	0.648	0.277	4.563
350TAT300-54	0.0566	50	0.537	0.311	1.83	0.525	0.989	1.324	1.570	0.833	0.354	10.601
350TAT300-68*	0.0713	50	0.676	0.391	2.30	0.657	0.986	1.695	1.583	1.150	0.497	14.887
362TAT300-30	0.0312	33	0.300	0.175	1.02	0.296	0.992	0.776	1.607	0.414	0.162	2.668
362TAT300-33	0.0346	33	0.333	0.195	1.13	0.327	0.992	0.861	1.608	0.491	0.197	3.256
362TAT300-43	0.0451	33	0.434	0.253	1.48	0.425	0.990	1.124	1.610	0.701	0.291	4.795
362TAT300-54	0.0566	50	0.544	0.318	1.85	0.531	0.988	1.425	1.619	0.901	0.372	11.134
362TAT300-68*	0.0713	50	0.685	0.400	2.33	0.665	0.985	1.823	1.631	1.242	0.521	15.604
400TAT300-30	0.0312	33	0.312	0.187	1.06	0.305	0.989	0.956	1.751	0.507	0.179	2.957
400TAT300-33	0.0346	33	0.346	0.208	1.18	0.338	0.989	1.061	1.751	0.601	0.219	3.609
400TAT300-43	0.0451	33	0.451	0.270	1.53	0.439	0.987	1.384	1.753	0.878	0.334	5.517
400TAT300-54	0.0566	50	0.565	0.339	1.92	0.548	0.985	1.754	1.761	1.126	0.427	12.795
400TAT300-68*	0.0713	50	0.712	0.427	2.42	0.686	0.982	2.239	1.774	1.544	0.596	17.831
550TAT300-33	0.0346	33	0.398	0.259	1.35	0.374	0.969	2.112	2.304	1.156	0.303	5.002
550TAT300-43	0.0451	33	0.518	0.338	1.76	0.485	0.968	2.755	2.306	1.795	0.511	8.430
550TAT300-54	0.0566	50	0.650	0.424	2.21	0.606	0.965	3.479	2.313	2.320	0.664	19.883
550TAT300-68*	0.0713	50	0.819	0.534	2.79	0.758	0.962	4.424	2.324	3.175	0.930	27.853
600TAT300-30	0.0312	33	0.374	0.250	1.27	0.347	0.962	2.307	2.483	1.168	0.272	4.491
600TAT300-33	0.0346	33	0.415	0.277	1.41	0.384	0.962	2.559	2.483	1.383	0.331	5.463
600TAT300-43	0.0451	33	0.541	0.360	1.84	0.498	0.960	3.337	2.484	2.144	0.557	9.184
600TAT300-54	0.0566	50	0.679	0.452	2.31	0.622	0.957	4.212	2.492	2.770	0.723	21.652
600TAT300-68*	0.0713	50	0.855	0.569	2.91	0.778	0.955	5.351	2.502	3.883	1.055	31.582
800TAT300-30	0.0312	33	0.437	0.312	1.49	0.376	0.928	4.407	3.177	2.121	0.365	6.029
800TAT300-33	0.0346	33	0.484	0.346	1.65	0.416	0.927	4.887	3.177	2.512	0.444	7.320
800TAT300-43	0.0451	33	0.631	0.451	2.15	0.540	0.925	6.372	3.178	3.880	0.738	12.173
800TAT300-54	0.0566	50	0.792	0.565	2.69	0.675	0.923	8.028	3.184	5.001	0.957	28.659

**Notes:** 1. Gross properties are based on the full section away from flange slots. 2. Net area is based on the section through the flange slots. 3. Weight is nominal weight of the gross section, not reduced for flange slots. 4. Effective properties are calculated in accordance with the 2016 NASPEC with 2018 Supplement (AISI S100-16/S1-18 and AISI S100-12). For effective flange widths, the compression flange (before local buckling) is taken as the portion of the flange between the web and the slot (the slot and any steel beyond the slot is considered absent). The tension flange is taken as the net flange at the slots. 5. Cold-work of forming has not been considered for effective properties. 6. Web width-to-thickness ratio exceeds 200. Web stiffeners are required at points of concentrated loads or reactions. 7. IBC 2006, 2009, 2012, 2015 and 2018 compliant.

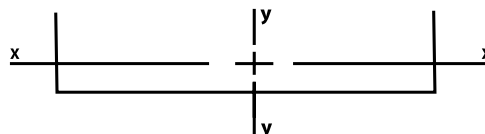

**INNOVATION, SERVICE, QUALITY**

[www.tellingindustries.com](http://www.tellingindustries.com)



1. Install floor track, secure with screws.

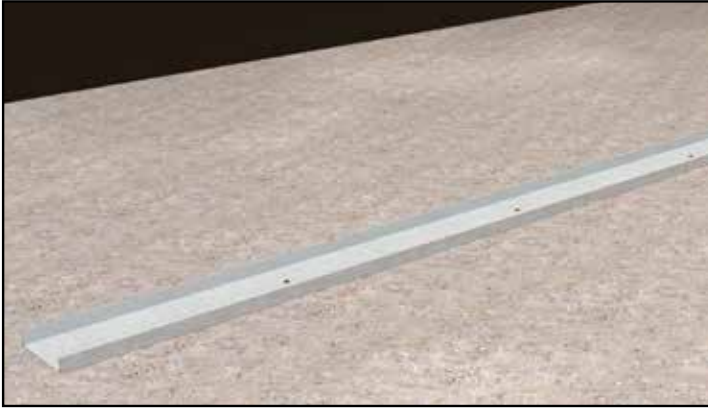

2. Install slotted track on ceiling, secure with screws.

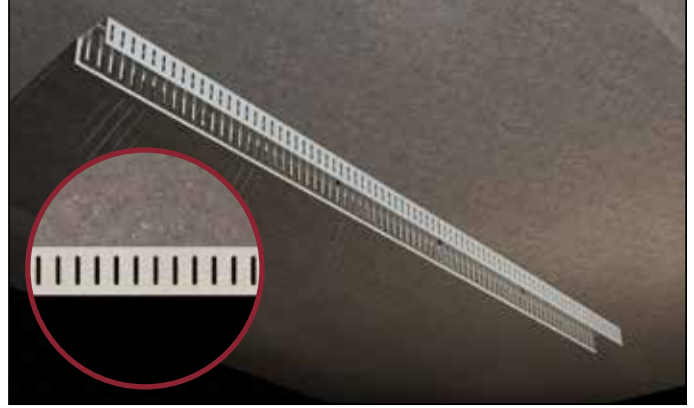

3. Cut stud 7/8" short.



4. Twist studs into the track.

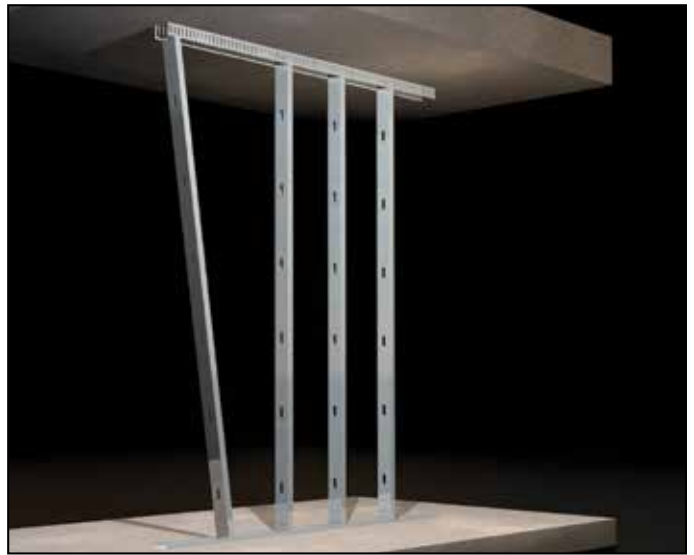

5. Screw studs to bottom track.



6. Screw studs to slotted track. Screw into the center of the track slot.



7. Cut gypsum 1-1/2" short of CLG. Attach gypsum with screws.

8. Install 5/8" gypsum board. Attach gypsum with screws.

9. Install top screws 3-4" below CLG. NO gypsum screws through slotted track.



10. Install mineral wool 2 x 2 strips, fire rated caulking or fire rated counter measures.



11. Install insulation.

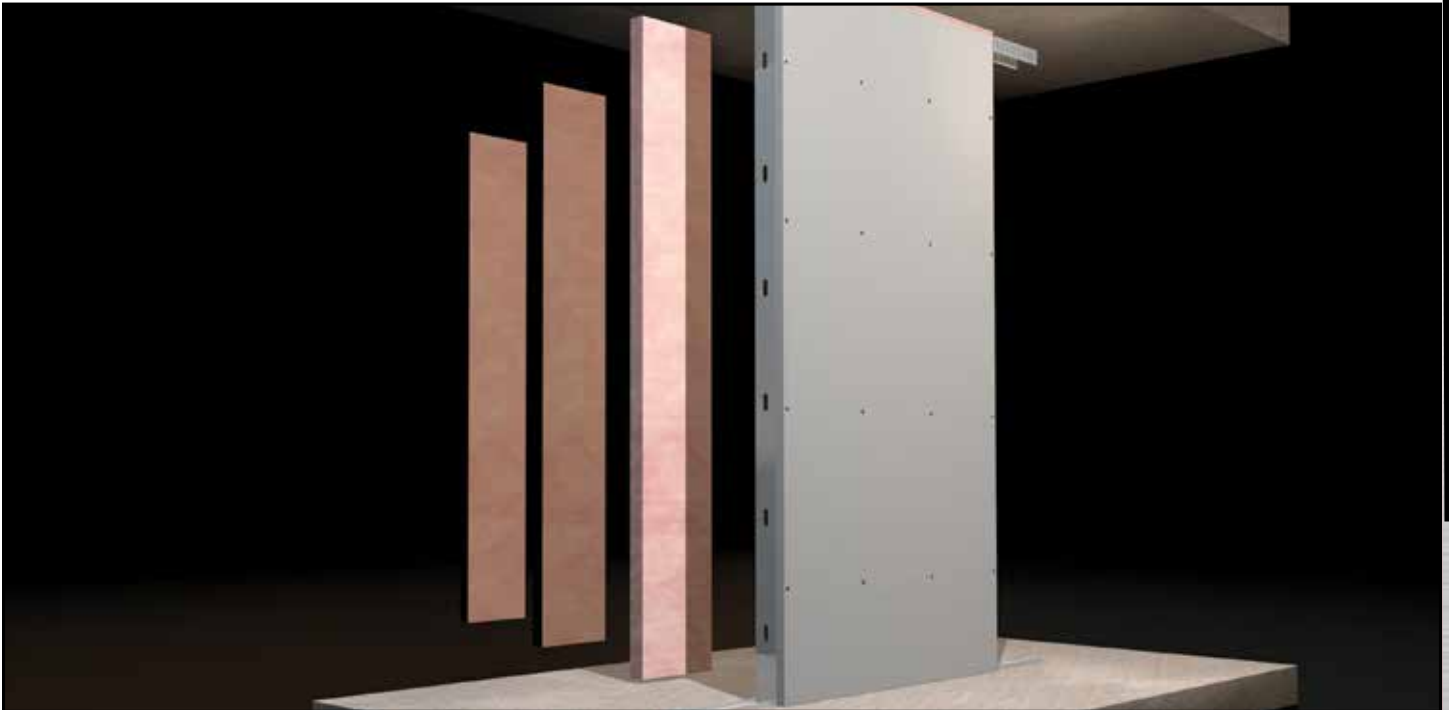

**GET THE  
INSTRUCTION  
VIDEO!**



INNOVATION, SERVICE, QUALITY

[www.tellingindustries.com](http://www.tellingindustries.com)





**Corporate Headquarters**

4420 Sherwin Road  
Willoughby, OH 44094  
Phone: 440-974-3370  
Toll Free: 866-FRAME-TI(372-6384)  
Fax: 440-974-3408  
E-mail: [sales.corp@tellingindustries.com](mailto:sales.corp@tellingindustries.com)

**Midwest Facility**

2105 Larrick Road  
Cambridge, OH 43725  
Phone: 740-435-8900  
Toll Free: 866-35STUDS (357-8837)  
Fax: 740-435-8915  
E-mail: [sales.oh@tellingindustries.com](mailto:sales.oh@tellingindustries.com)

**Midsouth Facility**

1400 Southwire Drive  
Osceola, AR 72370  
Phone: 870-563-6065  
Toll Free: 888-711-3124  
Fax: 870-563-2471  
E-mail: [sales.ar@tellingindustries.com](mailto:sales.ar@tellingindustries.com)

**Northeast Facility**

1050 Kennedy Road  
Windsor, CT 06095  
Toll Free: 866-372-6384  
Fax: 440-974-3408  
E-mail: [sales.corp@tellingindustries.com](mailto:sales.corp@tellingindustries.com)

Revised 3-8-2014

**THE LEADER IN METAL FRAMING INNOVATION!**