

LIGHT GAUGE METAL FRAMING ACCESSORIES

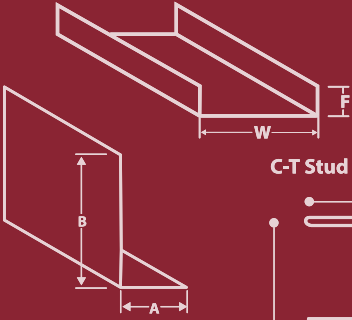

BuildStrong.com

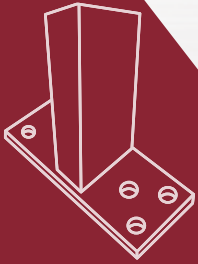

C-T Stud

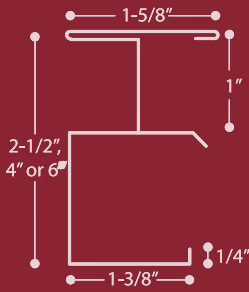

C-T Stud Detail

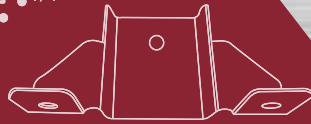
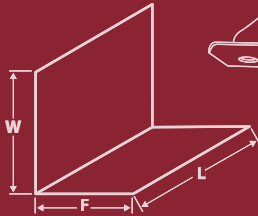
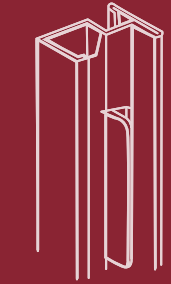

J-L Corner

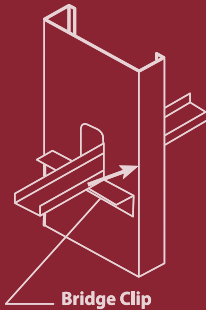
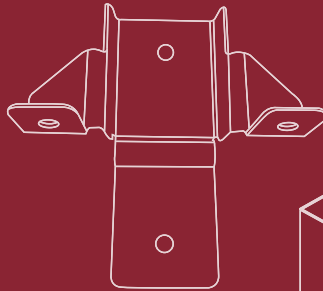
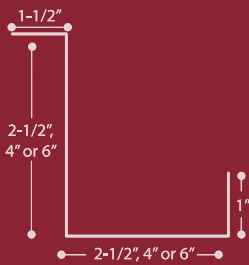

Bridge Clip

J Track

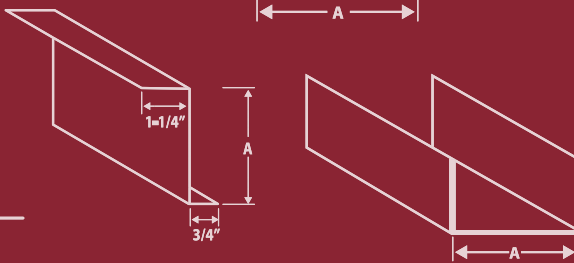
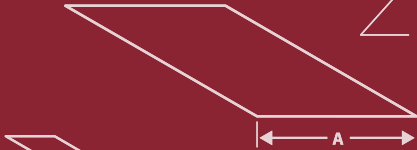
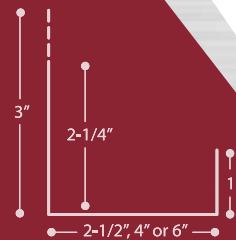

THE LEADER IN METAL FRAMING INNOVATION

ACCESSORIES - TABLE OF CONTENTS

Knee Wall Support Bracket Assembly <i>TELLING INNOVATION</i>	3
VersaDry Track System <i>TELLING INNOVATION</i>	4-6
True-Brace Mechanical Bridging and Bracing <i>TELLING INNOVATION</i>	7
True-Bridge Clips <i>TELLING INNOVATION</i>	8
TRC Standard Rigid Clips <i>TELLING INNOVATION</i>	9-10
TBKC Block Clip <i>TELLING INNOVATION</i>	11
True-Flatstrap (FS) <i>TELLING INNOVATION</i>	12
T-Bead Corner Bead <i>TELLING INNOVATION</i>	12
T-Block Wall Blocking <i>TELLING INNOVATION</i>	13
Titan Header System <i>TELLING INNOVATION</i>	14
Slotted Track - (True Action) 25" and 3"	15-16
Area Separation Wall Framing	17
H stud	
C Track	
Shaftwall System	18-19
CT Stud	18
J Track	19
J-L Corner	19
Resilient Furring Channel (RC-1 & RC-2)	20
Acoustical Data	
Drywall Furring Channel (DWFC)	21
(DWFC) Allowable Ceiling Spans - L/240	
(DWFC) Allowable Ceiling Spans - L/360	
(CRC) Cold-Rolled Channel	22
U-Channel (CRC) Section Properties	
Allowable U-Channel (CRC) Ceiling Spans - L/240	
Allowable U-Channel (CRC) Ceiling Spans - L/360	
Furring and Miscellaneous	23
Z-Furring (ZFC)	
Reveal Trim (RT)	
093 Expansion Control Joint	
Custom Leg Track (CLT)	
Web Stiffeners (WS)	
Utility Angle/Rolled Angle (RA)	



Knee Wall Support Bracket Assembly: What is it? An engineered system comprised of a 1/2" steel base plate welded to a 14ga structural stud.

In the construction industry, a "knee wall" is a term used to describe a short wall that is typically half the height of a full-sized wall. Also known as a "pony wall" or "cripple wall," knee walls are used for various purposes in building design, including providing structural support, dividing spaces, and enhancing aesthetic appeal.

TELLING'S KNEE WALL STUD & BASE PLATE:

- Knee Wall Stud & Base Plate are loaded perpendicular to the leg
- Knee Wall Stud is 300S162-68 14 ga. Competing products utilize 12ga material
- Base Plate is 8" x 3-3/8" and 1/2" thick with groove for Stud
- 1 Knee Wall Stud per Support Stud & Base Plate. Competitive products utilize 2 studs per support bracket
- Higher Allowable Loads than competing products

Knee Wall Assembly

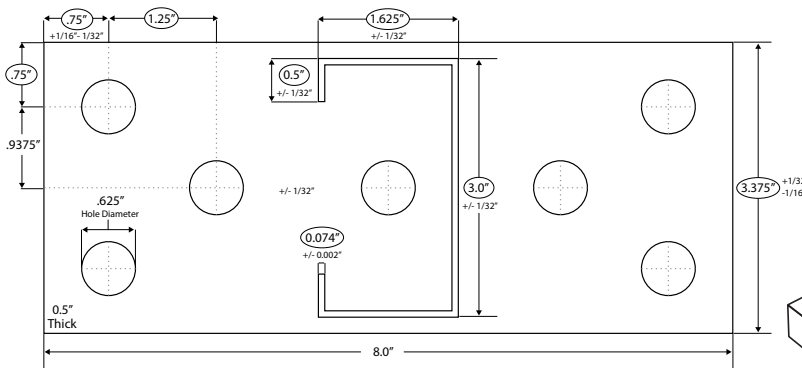
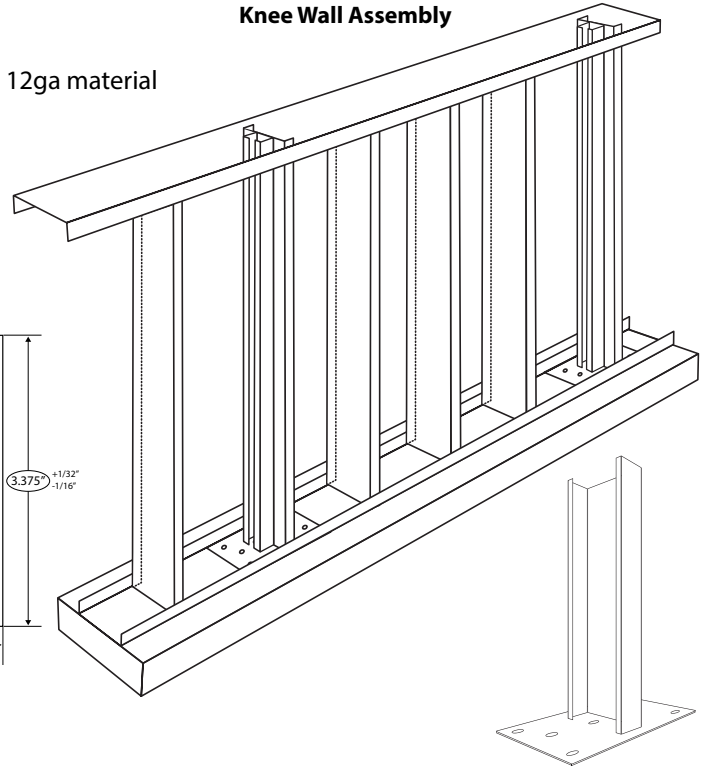

Base plate thickness = 1/2" (36ksi)
 Bolt size = 1/2" Hole size = 5/8"
 Knee wall stud = 300S162-68

Allowable Bending Capacity (kip-in)				Knee Wall Support Stud: 300S162-68 (50 ksi) Anchor quantity: 4 at each corner Anchor Type: Hilti Kwik-TZ2 Anchor Size: 1/2 inch Concrete Thickness: 5.5 inches Concrete Strength (cracked): 3000 psi Embedment: 3.25 inches I_{eff} 0.6720 in ⁴	Allowable Point Load Applied at the Top (lbf)						
Height (in)	Pony Wall Section	Stud to Baseplate Weld	Anchor to concrete		Combined Strength and Deflection						
					L/90	L/120	L/180	L/240	L/360	L/480	L/600
24	14.04	12.66	12.57		524	524	524	524	524	430	344
36	13.69	12.66	12.57	349	349	349	349	255	191	153	
48	12.50	12.66	12.57	260	260	260	215	143	108	86	
Allowable Distributed Load Applied along the Wall (plf)											
Height (in)	Strength Limit State	Combined Strength and Deflection									
		L/90	L/120	L/180	L/240	L/360	L/480	L/600			
24	524	524	524	524	524	524	524	459			
36	233	233	233	233	233	227	170	136			
48	130	130	130	130	130	96	72	57			

Representative loads based on specific quantity, type of anchors and concrete thickness. For additional anchor type and concrete thickness refer to detailed knee-wall technical catalog.



VERSADRY DRYWALL TRACK

VersaDry protects walls from water damage with its 2" shelf that lifts drywall off the floor.

**KEEPS
GYPSUM DRY**

**ELEGANT
FIT & FINISH**

**IMPROVES
ACCOUSTICAL
PERFORMANCE**

**HELPS REDUCE
MOLD GROWTH**

**IMPROVES FIRE
RESISTANCE**

**DESIGN YOUR BUILDING
TO PERFORM!**

**NO
CAULK NEEDED
SAVES \$\$\$**



HOSPITALS

SCHOOLS

APARTMENTS

KITCHENS

POTENTIAL WET ENVIRONMENTS

HOSPITALITY



THE LEADER IN METAL FRAMING INNOVATION

www.BuildStrong.com • 1-866-372-6384



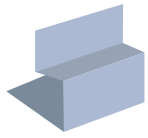

VERSADRY DRYWALL TRACK

VERSADRY DRYWALL TRACK SYSTEM

Patented system allows the installation of drywall to sit 2 inches off the floor on a steel shelf. This shelf mitigates the wicking of water both during construction and the life of the building.



VERSADRY TRACK PROTECTS DRYWALL FROM WATER DAMAGE

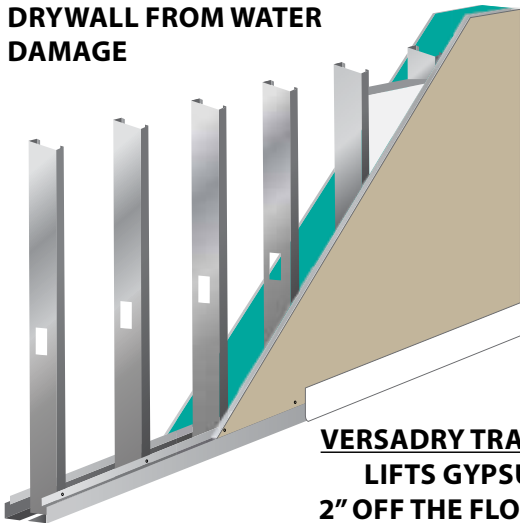

VERSADRY TRACK LIFTS GYPSUM 2" OFF THE FLOOR

Wall damage *without* VersaDry



IMPROVED AESTHETICS

Unightly wall damage is mitigated with VersaDry Technology. The damage created by gypsum in close contact with water and moisture on the floor is a thing of the past.



VERSADRY TRACK: 2 PIECE DESIGN (Ideal for retrofits)

Thickness Nomenclature	Non-Rate Length	1 Hour Rated	2 Hour Rated	Min Base Metal Thickness (in)	Design Thickness (in)	Min Yield Strength (ksi)	Standard Galvanization	Web Sizes (in)
VDT2-18	24'	10'	10'	0.0179"	0.0186"	33 ksi	G40	2 piece design. Any web size is possible
VDT2-30	12'	N/A	N/A	0.0296"	0.0312"			

VERSADRY TRACK: 1 PIECE DESIGN (Ideal for new construction)

Thickness Nomenclature	Non-Rate Length	1 Hour Rated + Clip	2 Hour Rated + Clip	Min Base Metal Thickness (in)	Design Thickness (in)	Min Yield Strength (ksi)	Standard Galvanization	Web Sizes (in)
VDT1-18	Max 24'	Max 24' Length (10' Recommended)		0.0179"	0.0186"	33 ksi	G40	3-5/8", 4", 5.5", 6"
VDT1-30				0.0296"	0.0312"			

VERSADRY DIMENSIONS

	Gypsum Ledge Height	Gypsum Ledge Width
Non-Rated	2.00"	0.688"
1 Hour Fire Rated	2.00"	0.688"
2 Hour Fire Rated	2.00"	1.295"

- KEEPS GYPSUM DRY
- IMPROVED FIRE RESISTANCE WITHOUT CAULK
- IMPROVED ACOUSTICAL PERFORMANCE
- ELEGANT FINAL FIT AND FINISHED APPEARANCE
- HELPS REDUCE MOLD GROWTH

VERSADRY TRACK CERTIFICATIONS:

FIRE RESISTANCE:



3rd party tested to meet a 1 hour & 2 hour Fire Rating for UL Wall Design U423 per ASTM E119

- 1 hour Fire Rating for UL Wall Design U423 per ASTM E119 with 18mil VersaDry Track, 1 layer of 5/8" Type X Gypsum, & 20ga 3-5/8" studs spaced 16"OC.
- 2 hour Fire Rating for UL Wall Design U423 per ASTM E119 with 18mil VersaDry Track, 2 layers of 5/8" Type X Gypsum, & 20ga 3-5/8" studs spaced 16"OC.
- VersaDry 1 piece design with clip at floor & ceiling passed ASTM E119 1-hour and 2-hour fire and hose stream test without caulk at Intertek certified independent 3rd party test lab.

ACOUSTICAL PERFORMANCE:

3rd part tested per ASTM E90-09 and calculated per ASTM E413-16.

- STC = 45 for Non-Fire Rated 18mil VersaDry Track w/ 1 layer of 5/8" Type X Gypsum
- STC = 48 for Non-Fire Rated 18mil VersaDry Track w/ 1 layer of Impact Resistant Gypsum
- STC = 46 for 1 hour Fire Rated 18mil VersaDry Track w/ 1 layer of Impact Resistant Gypsum
- STC = 53 for 2 hour Fire Rated 18mil VersaDry Track w/ 2 layers of 5/8" Type X Gypsum

CLICK HERE TO WATCH THE VIDEO

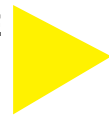

ACCESSORIES - VERSADRY DRYWALL TRACK SYSTEM

VERSADRY
2-PIECE DESIGN
NOW AVAILABLE

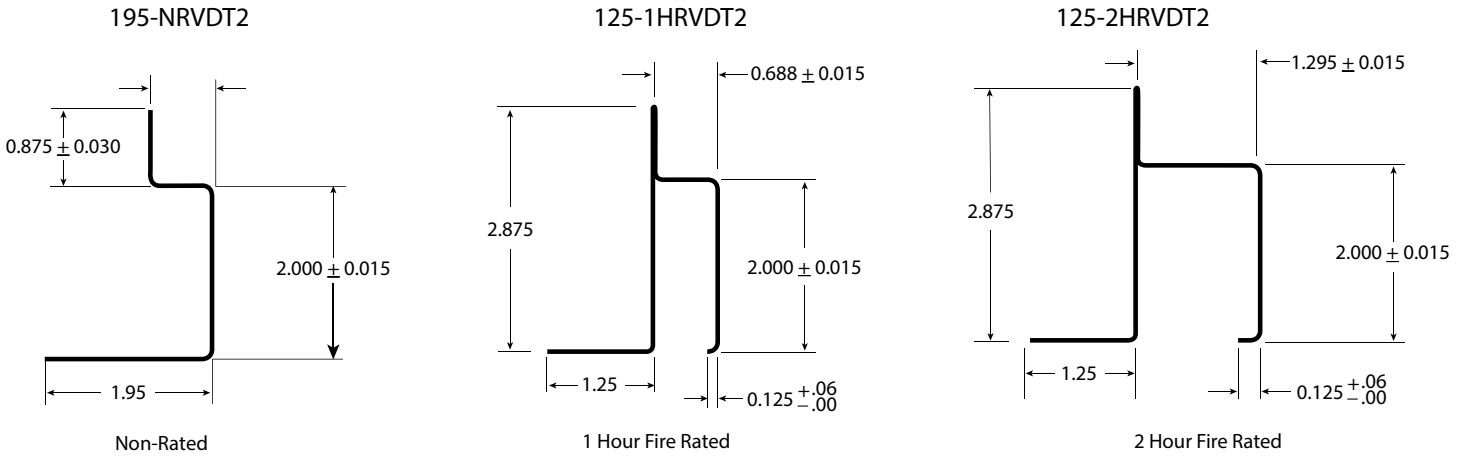
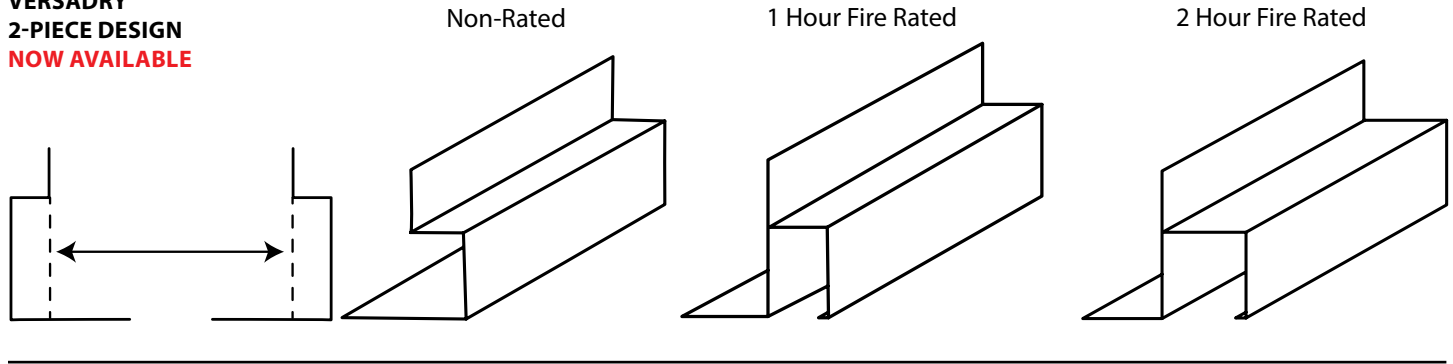

1-PIECE DESIGN
NOW AVAILABLE

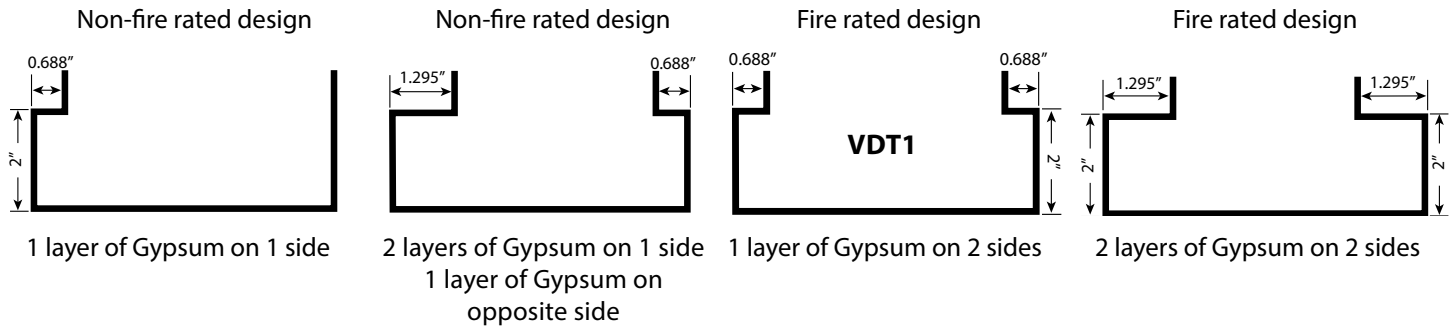

VersaDry with clip at floor without caulk

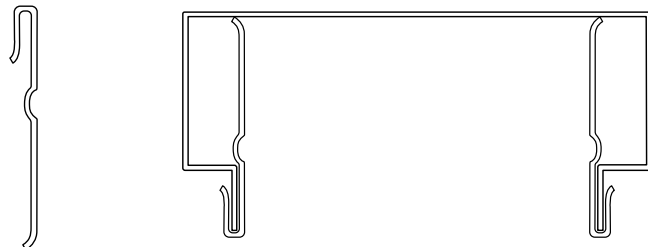

VersaDry with clip at ceiling without caulk



Product Data:

- Available in galvanized steel meeting ASTM A-1003 or hot-dipped galvanized steel meeting ASTM A-653, G60.
- Lengths: 52" stock length. (Other lengths available in 4" increments).
- Patent # 10,309,107 (T-Brace), Patent # 10,508,446 (T-Bridge).

Uses:

- Bridging, (lateral support) in walls carrying axial and/or wind loads.
- Clips are not required for many non-load bearing applications.

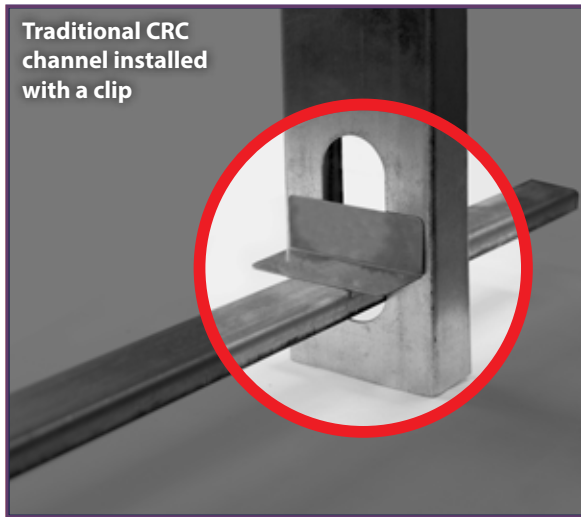

SEE THE VIDEO

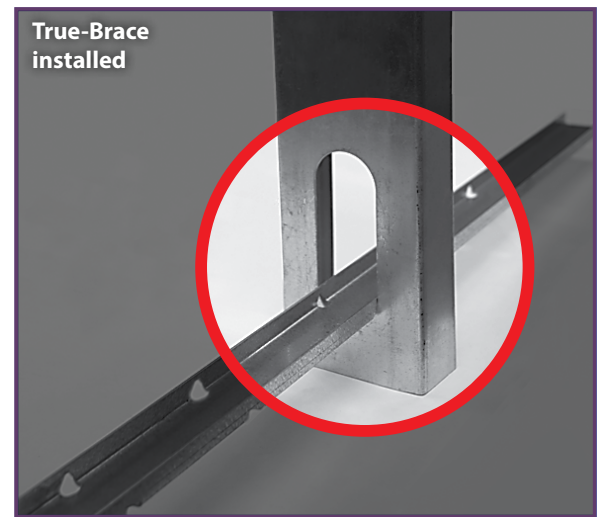

SECTION PROPERTIES

Section	Design Thickness (in)		Gross Properties								
			Fy (ksi)	Web (in)	Area (in ²)	Weight (lb/ft)	Ixx (in ⁴)	Sx (in ³)	Rx (in)	Iyy (in ⁴)	Ry (in)
TB150-54	0.0566	0.0538	50	1.57	0.132	0.45	0.0460	0.0053	0.590	0.002	0.125

Section	Design Thickness (in)		Effective Properties							
			Fy (ksi)	Web (in)	Area (in ²)	Weight (lb/ft)	I _{xd} (in ⁴)	S _{xe} (in ³)	Ma-L (in-k)	V _{ax} (lb)
TB150-54	0.0566	0.0538	50	1.57	0.132	0.45	0.0460	0.0053	1.586	1464

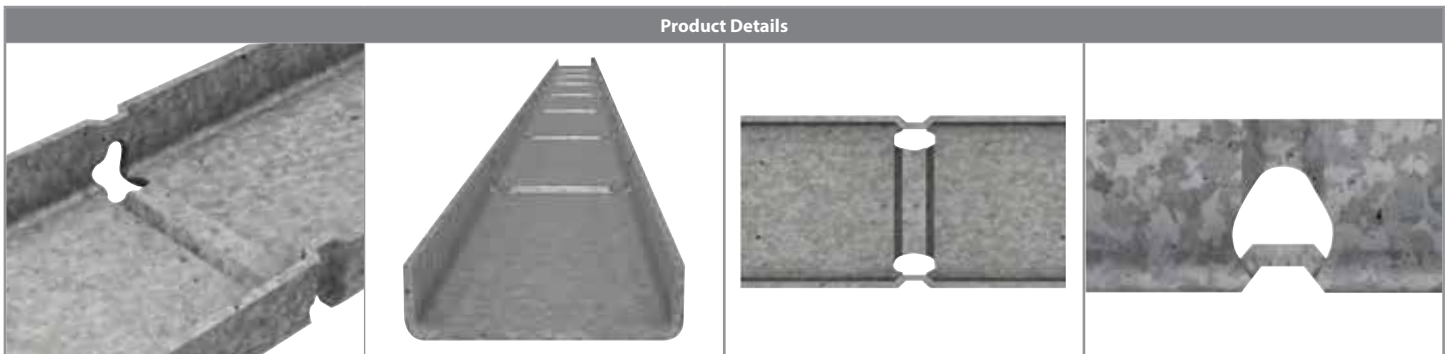

True-Brace with self nesting geometry to fit one part inside of another and secured with a screw.
True-Brace locking features spaced every 4" to accommodate 12", 16" and 24" on center stud spacing.

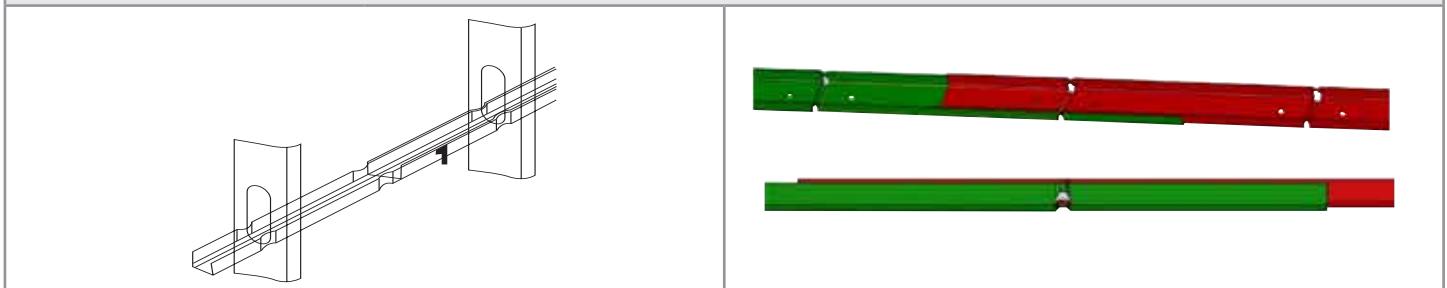



Product Data:

T-Bridge Clips are a highly engineered new product from Telling used with T-Brace or traditional CRC mechanical bridging.

Telling's T-Bridge clips were engineered with the installer in mind. The ergonomic design facilitates easy screw drive access and hands free assembly.

The patented T-Bridge Clips are made of 18 gauge, premium steel and are available in two functional designs, terminating and joining.



TYPES OF TRUE-BRIDGE CLIPS:

True-Bridge Clip (Terminating)

- Used to join True-Brace to a Stud at a corner, doorway, or end of wall
- 1.75" X 3.2" X 1.25"

True-Bridge Clip (Joining)

- Used to joint True-Brace to True-Brace or CRC to CRC for higher load applications
- 3.5" X 3.2" X 1.25"



Tabs prevent Clips from rotating facilitating "hands-free" installation

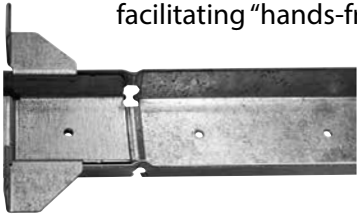

SEE THE VIDEO

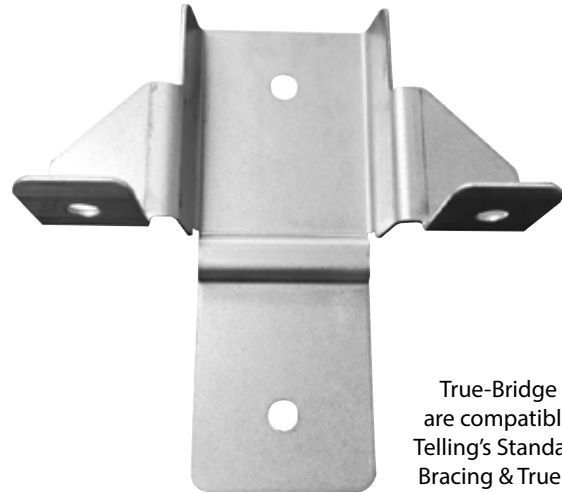
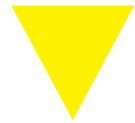

True-Bridge clips are compatible with Telling's Standard CRC Bracing & True-Brace.

FEATURES:

- Made of Galvanized Steel
- Highly Engineered for Ease of Installation
- Slides Easily into Place When Used in Conjunction with True-Brace

BENEFITS:

- Reduces Installation Time
- 10% Savings on Material and Labor Costs
- No Clips or Welding Required
- Easy Installation Due to Patented Design

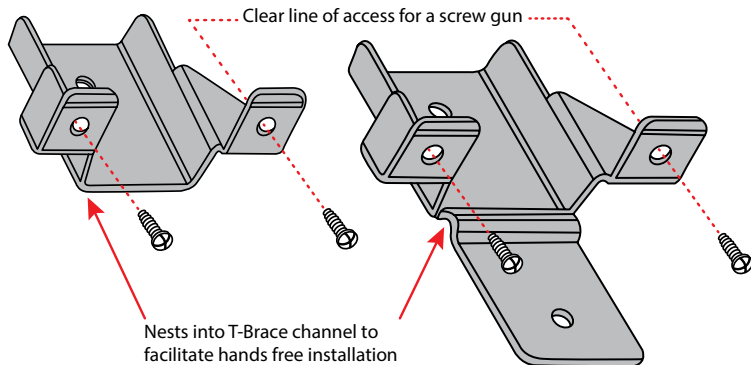

USES:

- Used to join True-Brace to a stud at a corner, doorway, or end of wall
- 1 Screw to True-Brace and up to 2 Screws to Stud
- Clip is also compatible with standard CRC Bracing



TELLING, THE CUSTOM CLIP EXPERT!

NEED SOMETHING SPECIAL? WE CAN DO IT!



We can drill and bend any darn thing!



CUSTOM LENGTHS AND HOLE PATTERNS

Illustration is an example of 1 of 1000's of possible custom hole patterns.

Developed in-house flexible manufacturing technology to make nearly any hole pattern & custom geometry with minimal leadtime, set up, and labor.

PRODUCT DATA:

- Maximum of 6 holes per pattern grouping
- Leg 1 + Leg 2 = max of 10", min of 1.5"
- Clip Length = max of 17", min of 2.0"

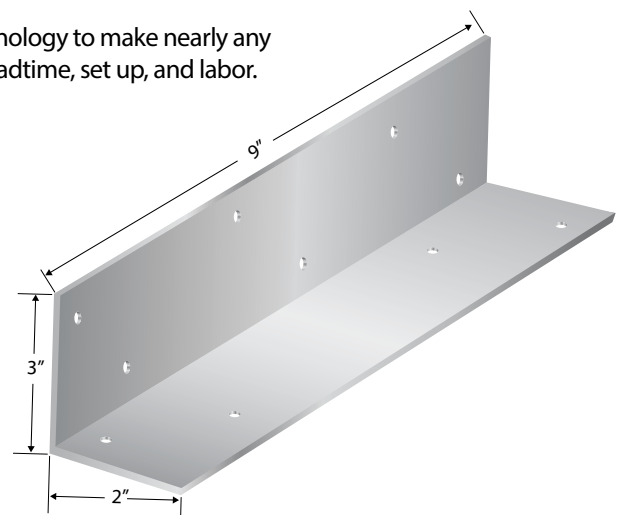
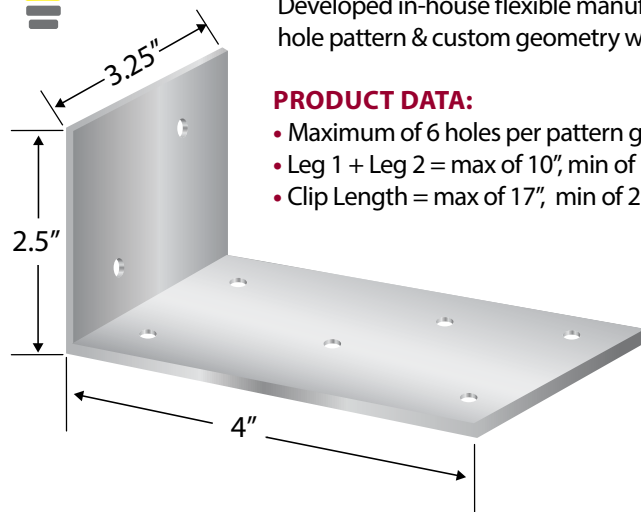

If your project needs connectors not shown in this catalog, please contact your inside sales rep or send an inquiry to www.buildstrong.com.

ACCESSORIES - TELLING RIGID CLIPS (TRC)



Telling Industries manufactures an extensive line of Metal Framing Connectors and Clips. Standard gauges and sizes are complimented with specialized and custom fabricated Clips to meet all your Metal Framing needs and available in standard G60 and optional G90 coatings. All Telling products, including Metal Framing Connectors, are proudly made in the USA.

TRC A Series Rigid Right Angle Clips Predominately Used to Attach Metal Framing to Metal Framing

Section	Clip Thickness	Leg Length (in)	Clip Length (in)	BKT Quantity
TRC223	0.0538" (16ga)	2" x 2"	3.0"	150
	0.0677" (14ga)			
	0.0966" (12ga)			
TRC225	0.0538" (16ga)	2" x 2"	5.0"	120
	0.0677" (14ga)			
	0.0966" (12ga)			
TRC227	0.0538" (16ga)	2" x 2"	7.0"	100
	0.0677" (14ga)			
	0.0966" (12ga)			
TRC229	0.0538" (16ga)	2" x 2"	9.0"	75
	0.0677" (14ga)			
	0.0966" (12ga)			
TRC2211	0.0538" (16ga)	2" x 2"	11.0"	30
	0.0677" (14ga)			
	0.0966" (12ga)			

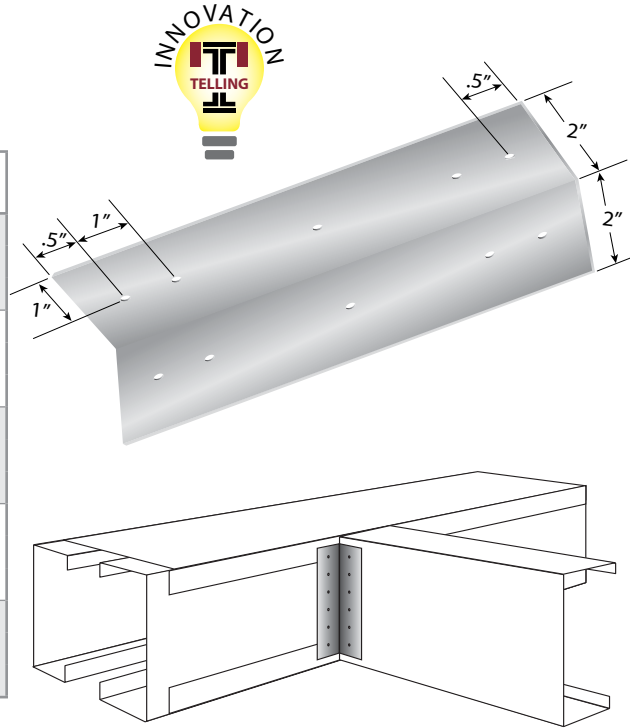

Clip allowable load data is available and 3rd party PE validated.

TRC B Series Rigid Right Angle Clips predominately used to attach Metal Framing to Metal Framing

Section	Clip Thickness	Leg Length (in)	Clip Length (in)	BKT Quantity
TRC133	0.0538" (16ga)	1.5" x 3"	3.0"	150
	0.0677" (14ga)			
	0.0966" (12ga)			
TRC143	0.0538" (16ga)	1.5" x 4"	3.5"	120
	0.0677" (14ga)			
	0.0966" (12ga)			
TRC145	0.0538" (16ga)	1.5" x 4"	5.5"	100
	0.0677" (14ga)			
	0.0966" (12ga)			
TRC147	0.0538" (16ga)	1.5" x 4"	7.5"	100
	0.0677" (14ga)			
	0.0966" (12ga)			
TRC149	0.0538" (16ga)	1.5" x 4"	9.5"	75
	0.0677" (14ga)			
	0.0966" (12ga)			
TRC1411	0.0538" (16ga)	1.5" x 4"	11.5"	30
	0.0677" (14ga)			
	0.0966" (12ga)			
TRC156	0.0538" (16ga)	1.5" x 5"	6.0"	50
	0.0677" (14ga)			
	0.0966" (12ga)			
TRC173	0.0538" (16ga)	1.5" x 7"	3.0"	50
	0.0677" (14ga)			
	0.0966" (12ga)			

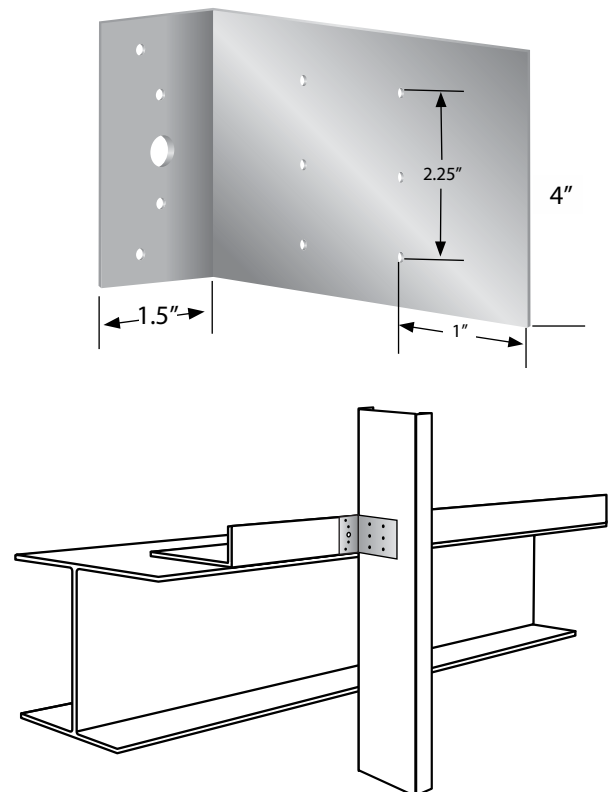

*All Sales are subject to Telling's Terms & Conditions found at www.buildstrong.com. Prices are subject to change without further notice. Please contact your Telling Sales Representative for further inquiries.

**Prices Listed are for each G60 clip when sold in BUCKET quantities. Individual (EA) cost on the clips will be +5% from the bucket price.



PRODUCT APPLICATION

TBKC products are cost effective and labor saving solution to creating superior backing support for wall shelving, cabinetry, heavy wall hangings, and other equipment.

Installation is simplified by using 2 screws to attach the clip to the stud flange with 2 or 3 screws attached to the wood blocking. Designed to mate with all stud flanges up to 3". Metal tabs support 2" x 6" structure grade lumber (#1 or better) as required by codes or specifications.

FEATURE AND BENEFITS

- Loads based on #8 screws
- Pre-punched guide holes
- Bent tabs for consistent wood positioning

MATERIAL COMPOSITION

- Mill certified steel
- ASTM A653/A653M
- 33 mil
 - 33 ksi yield strength
 - G60 galvanized coating

QUANTITY / ORDER INFORMATION

Part Number	Flange Width	Qty/Bucket	Lbs/Bucket
TBKC-33	1-1/4" to 3"	200	50

ALLOWABLE LOADS

Part Number	Stud Properties			F1 Allowable Loads (lbs)		F3 Allowable Loads (lbs)	
	Mil	Gauge	Fy (ksi)	2 #8 Screws	3 #8 Screws	2 #8 Screws	3 #8 Screws
TBKC-33	33	20 (S)	33	142	213	321	483

Notes:

1. The allowable loads are based on the steel properties of the members being connected, per AISI S100.
2. Allowable loads indicated on the table(s) are for force in single direction only. The designer shall use the combined forces check as required by AISI S100 if more than one force is applied to the connection.
3. The nominal strength of the screw must be at least 3.75 times the allowable loads.
4. Values include a 3.0 factor of safety.
5. Penetration of screws through joined materials should not be less than three exposed threads. Install and tighten screws in accordance with the screw manufacturer's recommendations.
6. Allowable loads have not been increased for wind, seismic activity, or other factors.

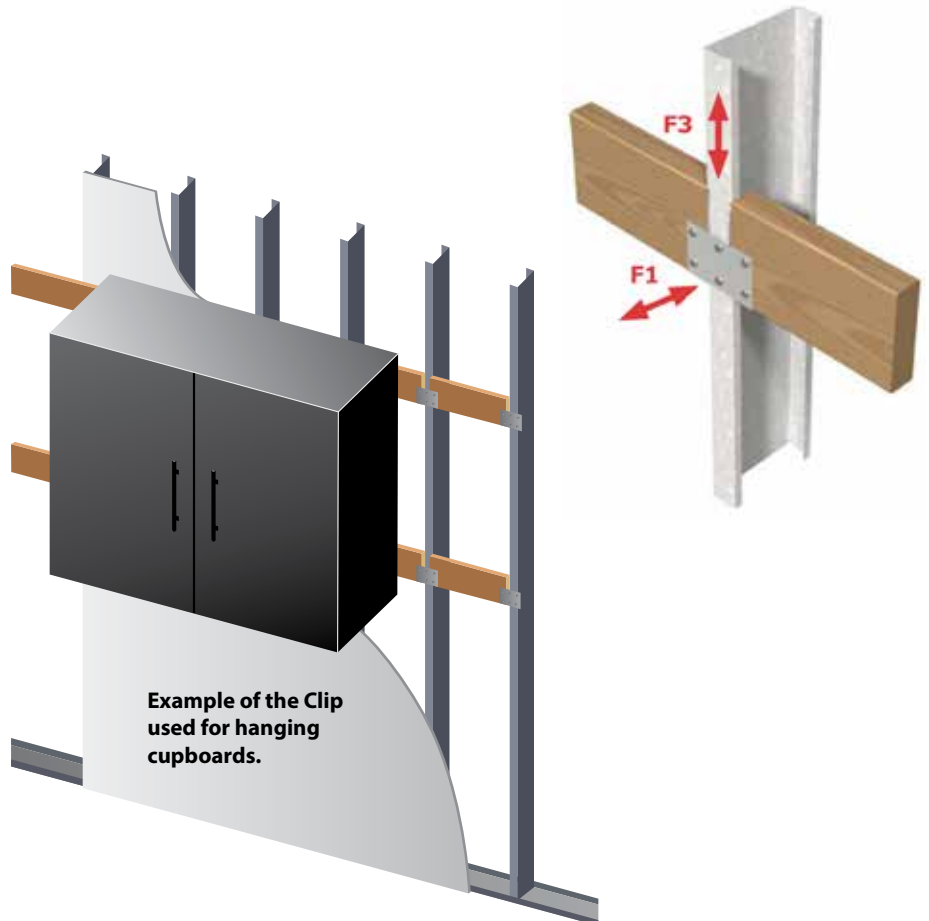
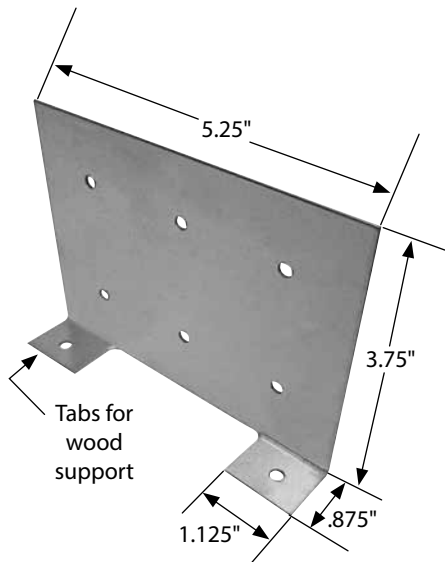



Product Data:

- Designation: FS(Width)-Mil
- Ex: FS200-30
- Stock widths: 2", 4", 6", 8" and 10"
- Custom Widths are available in increments of even inches
- Length: 10', 12', 14', 16', 18', 20', 22', & 24' (custom lengths available in 1' increments)
- Note: 16' through 24' length will have additional packaging costs
- 10 piece minimum order quantities must be strictly followed for 16' & longer lengths in order to package, ship, & handle safely
- Gauges:
- 33KSI: 25, 22, 20, 20S & 18 gauge
- 50KSI: 20S, 22, 16, 14 & 12 gauge
- Cut off angle: 90°, 45°, 40°, 35°, 30°, 25°, 20°, 15°, 10°, 5°
- Available in smooth (2"-10") and knurled textures from (2" - 8").
The knurled finish helps start a screw
- Coating:
- Drywall: Standard G-40 Hot Dipped Galvanized. Also Available in G-60 and G-90
- Structural: G-60 Hot Dipped Galvanized. Also Available in G-60 and G-90
- Meets applicable ASTM's for Structural and Drywall applications:
- ASTM- A1003, A-653, A924, C-645, C754, C955, C1007



Uses:

- Provides tension force resistance in shear wall assemblies
- Backing plates for fixtures, railings and where ever additional pullout strength is required
- Resists racking of prefricated wall assemblies while handling, transporting, and erecting

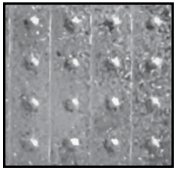
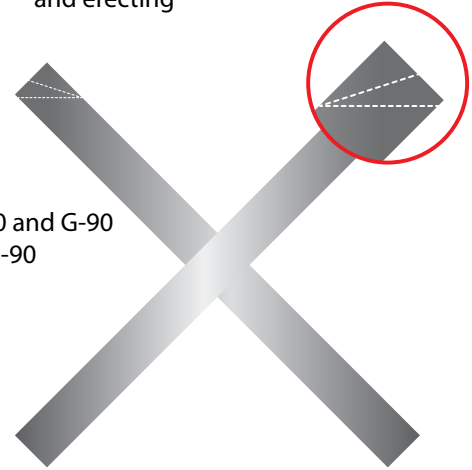

Knurled pattern for better screw starting.

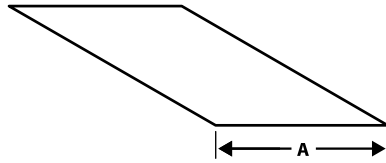

(DCB) DRYWALL CORNER BEAD
TRUEBEAD™

Product Data:

- Made of galvanized steel
- Optimized bend angle
- Reinforces drywall corners
- Prevents dents, scrapes and damage
- Deeper knurling for superior adhesion
- Staggered hole pattern for a smoother finish

Uses:

- Provides durable protection for drywall external corners.
- Specify hot-dipped for moist or humid conditions.

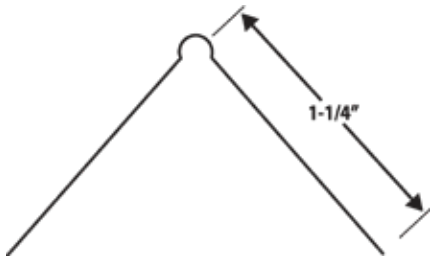

Length	Pieces Per Carton	Cartons Per Pallet	Pieces Per Pallet	Lineal Feet Per Carton
8'	63	50	3150	503
9'	56	50	2800	503
10'	50	50	2500	500
12'	50	50	2500	600

New nose design requires less mud for a superior finish every time!

Optimized bend angle

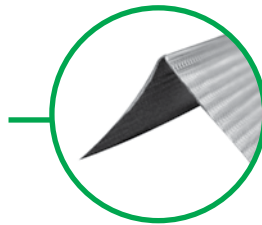

Deeper knurling for superior adhesion

Revised hole pattern for a smoother finish

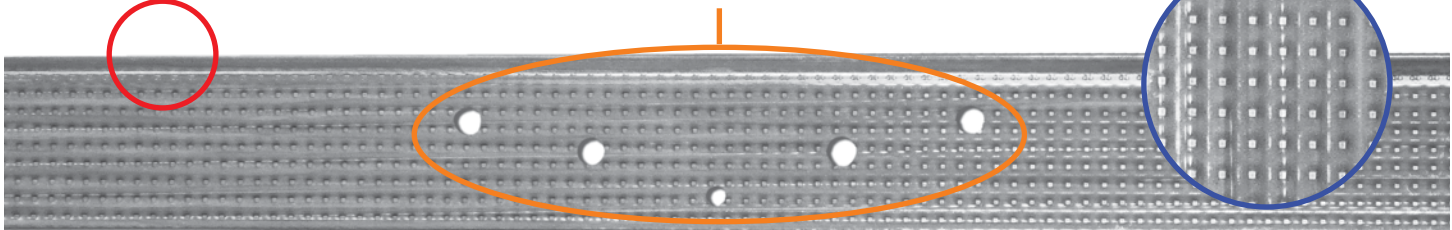

ACCESSORIES - T-BLOCK WALL BLOCKING

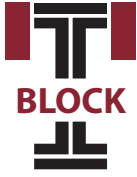

Blocking a metal stud wall refers to installing a short piece of stud horizontally between the vertical studs. The purpose of blocking is to provide an attachment support point for mounted construction features like shelving, frames, cabinets, railings or other fixed hardware.

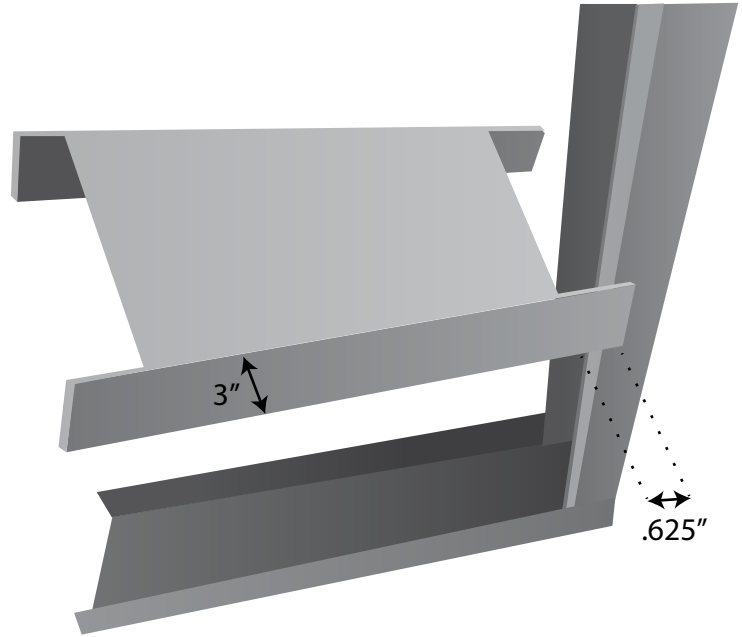

Product offering:

- Blocking Gauges: 16ga and 20ga (30 mil), G60 is standard.
- Lengths: Sized to accommodate 12", 16", & 24" on-center stud spacing
- Web Sizes: Fits 3-5/8", 4", 6", 8", 10", 12" web sizes.
- Leg/Flange: 3"
- Industry Standard Blocking Nomenclature:
TB362-300-S16-54, which is Track Blocking, 3-5/8" web, 3" flange, Stud spacing of 16" on center, 54 mils thick

T-Block Part No.	Gauge	Minimum Thickness (in)	Design Thickness (in)	Tensile Strength (KSI)	Coating	Web (in)	Flange (in)	Stud Spacing (O.C.)	Standard Packaging
TBLK362-300-S12-30	20	0.0296	0.0312	33	G40	3-5/8"	3"	12"	"10pc Bundles"
TBLK362-300-S16-30	20	0.0296	0.0312	33	G40	3-5/8"	3"	16"	
TBLK362-300-S24-30	20	0.0296	0.0312	33	G40	3-5/8"	3"	24"	
TBLK362-300-S12-54	16	0.0538	0.0566	50	G60	3-5/8"	3"	12"	
TBLK362-300-S16-54	16	0.0538	0.0566	50	G60	3-5/8"	3"	16"	
TBLK362-300-S24-54	16	0.0538	0.0566	50	G60	3-5/8"	3"	24"	
TBLK600-300-S12-30	20	0.0296	0.0312	33	G40	6"	3"	12"	
TBLK600-300-S16-30	20	0.0296	0.0312	33	G40	6"	3"	16"	
TBLK600-300-S24-30	20	0.0296	0.0312	33	G40	6"	3"	24"	
TBLK600-300-S12-54	16	0.0538	0.0566	50	G60	6"	3"	12"	
TBLK600-300-S16-54	16	0.0538	0.0566	50	G60	6"	3"	16"	
TBLK600-300-S24-54	16	0.0538	0.0566	50	G60	6"	3"	24"	

T-Block Item No.	Minimum Thickness (in)	Design Thickness (in)	Tensile Strength (KSI)	Web (in)	Flange (in)	Max Stud Spacing (O.C.)	Stud & Track	Allowable Load (lbf)
TBLK362-300-30	0.0296	0.0312	33	3-5/8"	3"	16"	20 ga (30 mil) Fy=33 ksi	Horizontal: 249 lbf Vertical: 339 lbs
TBLK362-300-54	0.0538	0.0566	50	3-5/8"	3"	16"	12 ga (97 mil) Fy=50 ksi	Horizontal: 647 lbf Vertical: 692 lbs
							16 ga (54 mil) Fy=50 ksi	Horizontal: 648 lbf Vertical: 926 lbs
							20 ga (30 mil) Fy=33 ksi	Horizontal: 288 lbf Vertical: 396 lbs

Blocking is connected to studs with (1) #10-16 screw at each flange

Allowable Loads were determined based on the test results and 3rd party PE reliability analysis per AISI S100-16 Chapter K

ACCESSORIES - ONE PIECE HEADER FRAMING SYSTEM

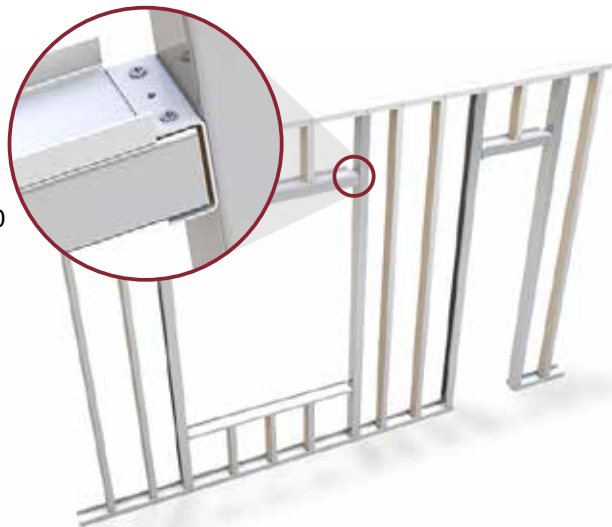

**CLICK HERE
TO WATCH THE
INSTALLATION
VIDEO**

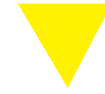

Product Data:

- Material Specifications: ASTM 1003, Grade 50
- one piece wide flange header and jamb
 - Widths: 3-5/8", 4", 6", & 8"
 - Flanges: 2, 2-1/2" & 3"
 - Lip/Return: 7/8"
 - Thickness:
 - 54 mils (16ga) 50KSI
 - 68 mils (14ga) 50KSI
 - 97 mils (12ga) 50KSI

Uses:

- The Titan one piece wide flange header and jamb offers a better solution for framing multiple openings than the conventional lay-in or boxed headers
- Saves over 50% in installation and material over convention framing
- No more built-up jambs and headers
- Header quickly attaches to jamb with fully tested, pre-drilled Titan Header Clip



Physical Properties				Gross Properties								Effective Properties								Torsional Properties					
Section	Thickness (in)	Lip (in)	Fy (ksi)	Area (in ²)	Weight (lb/ft)	Ix (in ⁴)	Sx (in ³)	Rx (in)	Iy (in ⁴)	Sy (in ³)	Ry (in)	Ixe (in ⁴)	Sxe (in ³)	Max (in-k)	Vax (web) (lb)	Iye (in ⁴)	Sye (in ³)	May (in-k)	Vay (flanges) (lb)	Jx1000 (in ⁴)	Cw (in ⁶)	Xo (in)	m (in)	Ro (in)	β
362TH250-54	0.0566	0.875	50	0.563	1.917	1.242	0.685	1.485	0.535	0.362	0.975	1.242	0.589	17.64	3372	0.422	0.314	9.40	4706	0.602	2.137	-2.373	1.381	2.964	0.359
362TH250-68	0.0713	0.875	50	0.702	2.389	1.531	0.845	1.477	0.656	0.443	0.967	1.531	0.781	23.37	4370	0.534	0.404	12.10	5731	1.190	2.612	-2.355	1.371	2.943	0.360
362TH250-97	0.1017	0.875	50	0.978	3.329	2.085	1.150	1.460	0.882	0.595	0.950	2.085	1.134	38.15	5943	0.714	0.547	16.37	7595	3.373	3.497	-2.317	1.351	2.898	0.361
362TH300-54	0.0566	0.875	50	0.620	2.110	1.422	0.785	1.515	0.822	0.469	1.151	1.386	0.628	18.81	3372	0.653	0.408	12.20	5767	0.662	3.237	-2.860	1.640	3.435	0.307
362TH300-68	0.0713	0.875	50	0.773	2.631	1.756	0.969	1.507	1.010	0.576	1.143	1.756	0.812	24.31	4370	0.828	0.525	15.70	7068	1.310	3.965	-2.841	1.630	3.413	0.307
362TH300-97	0.1017	0.875	50	1.080	3.675	2.400	1.324	1.491	1.368	0.779	1.126	2.400	1.259	37.68	5943	1.115	0.715	21.41	9502	3.723	5.337	-2.803	1.610	3.369	0.307
400TH250-54	0.0566	0.875	50	0.585	1.989	1.556	0.778	1.632	0.555	0.366	0.975	1.556	0.662	19.82	3372	0.432	0.321	9.60	4706	0.624	2.519	-2.311	1.355	2.992	0.404
400TH250-68	0.0713	0.875	50	0.729	2.480	1.920	0.960	1.623	0.681	0.449	0.967	1.920	0.880	26.33	4871	0.563	0.408	12.22	5731	1.235	3.081	-2.292	1.345	2.971	0.405
400TH250-97	0.1017	0.875	50	1.016	3.459	2.621	1.311	1.606	0.917	0.603	0.950	2.621	1.296	43.59	6658	0.762	0.562	16.82	7595	3.504	4.135	-2.254	1.325	2.926	0.406
400TH300-54	0.0566	0.875	50	0.641	2.182	1.777	0.888	1.664	0.852	0.476	1.153	1.734	0.705	21.11	3372	0.667	0.415	12.43	5767	0.685	3.819	-2.792	1.613	3.449	0.345
400TH300-68	0.0713	0.875	50	0.800	2.722	2.195	1.098	1.657	1.048	0.584	1.145	2.195	0.913	27.33	4871	0.870	0.530	15.85	7068	1.356	4.683	-2.774	1.603	3.428	0.345
400TH300-97	0.1017	0.875	50	1.118	3.805	3.007	1.504	1.640	1.421	0.791	1.127	3.007	1.430	42.81	6658	1.858	0.735	21.99	9502	3.855	6.317	-2.735	1.583	3.383	0.346
600TH250-54	0.0566	0.875	50	0.698	2.375	3.963	1.321	2.383	0.642	0.384	0.959	3.963	1.203	32.21	2823	0.455	0.329	9.84	4706	0.745	5.344	-2.031	1.230	3.275	0.615
600TH250-68	0.0713	0.875	50	0.871	2.965	4.908	1.636	2.373	0.788	0.471	0.951	4.908	1.551	43.46	5350	0.610	0.417	12.48	5731	1.476	6.563	-2.013	1.221	3.254	0.617
600TH250-97	0.1017	0.875	50	1.220	4.151	6.754	2.251	2.353	1.063	0.635	0.934	6.754	2.251	73.36	10472	0.928	0.590	17.66	7595	4.205	8.880	-1.976	1.201	3.211	0.622
600TH300-54	0.0566	0.875	50	0.754	2.567	4.462	1.488	2.432	0.986	0.501	1.143	4.390	1.277	33.68	2823	0.700	0.425	12.72	5767	0.806	8.115	-2.483	1.481	3.659	0.539
600TH300-68	0.0713	0.875	50	0.943	3.207	5.534	1.845	2.423	1.214	0.616	1.135	5.534	1.610	45.70	5350	0.937	0.541	16.19	7068	1.597	9.992	-2.465	1.471	3.638	0.541
600TH300-97	0.1017	0.875	50	1.322	4.497	7.639	2.546	2.404	1.649	0.835	1.117	7.639	2.442	71.74	10472	1.431	0.771	23.09	9502	4.556	13.587	-2.427	1.451	3.594	0.544
800TH250-54	0.0566	0.875	50	0.811	2.760	7.765	1.941	3.094	0.705	0.395	0.932	7.765	1.756	44.21	2091	0.463	0.330	9.88	4706	0.866	9.639	-1.818	1.130	3.708	0.759
800TH250-68	0.0713	0.875	50	1.014	3.450	9.638	2.409	3.083	0.865	0.485	0.924	9.638	2.291	60.19	4221	0.628	0.420	12.57	5731	1.718	11.864	-1.801	1.120	3.688	0.762
800TH250-97	0.1017	0.875	50	1.423	4.843	13.327	3.332	3.060	1.167	0.654	0.906	13.327	3.332	103.13	10885	0.977	0.598	17.89	7595	4.907	16.123	-1.765	1.102	3.647	0.766
800TH300-54	0.0566	0.875	50	0.868	2.952	8.657	2.164	3.159	1.085	0.517	1.118	8.579	1.826	45.96	2091	0.712	0.427	12.78	5767	0.927	14.643	-2.244	1.372	4.033	0.690
800TH300-68	0.0713	0.875	50	1.085	3.693	10.758	2.758	3.149	1.336	0.636	1.110	10.758	2.371	62.83	4221	0.962	0.545	16.30	7068	1.839	18.066	-2.226	1.363	4.012	0.692
800TH300-97	0.1017	0.875	50	1.525	5.189	14.913	3.728	3.127	1.817	0.863	1.092	14.913	3.576	100.11	10885	1.502	0.781	23.39	9502	5.257	24.677	-2.188	1.343	3.970	0.696

1. Section properties are based on the AISI S100-07 with Supplement S2-10 with U.S. provisions.
 2. The structural properties are based on allowable strength design (ASD).
 3. The distortional buckling calculations are based on K_D=0.
 4. Effective properties incorporate the strength increase from the cold work of forming.
 5. Tabulated gross properties are based on the full-unreduced cross section away from punch outs.

Header Size		Titan Header Clip Allowable Load Capacity	
Web Depth (in)	Flange Width (in)	Vertical Load (lbs)	Horizontal Load (lbs)
03-5/8	2-1/2	1140	1520
6		1140	1740
8		1140	1930
3-5/8	3	1140	1520
6		1140	1740
8		1140	1930





Product Data:

- UL Classified in over 80 approved fire-rated systems
- Meets movement and cycling requirements for ANSI/UL 2079
- Custom web, leg and lengths are available (Custom slot sizes are not available)
- Integrated with traditional wall systems
- Easy installation reduces labor costs

Uses:

- Fire-rated deflection system
- Positive attachment provided for wall strength
- Standard Slotted Track allows vertical movement
- Absorbs head-of-wall and floor extension or compression movement

2.5" SLOTTED TRACK

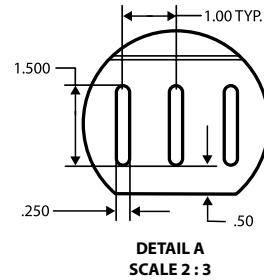
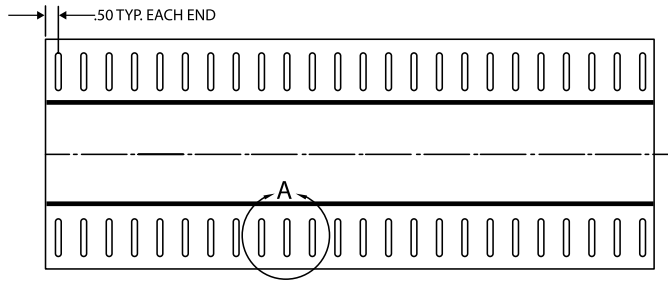
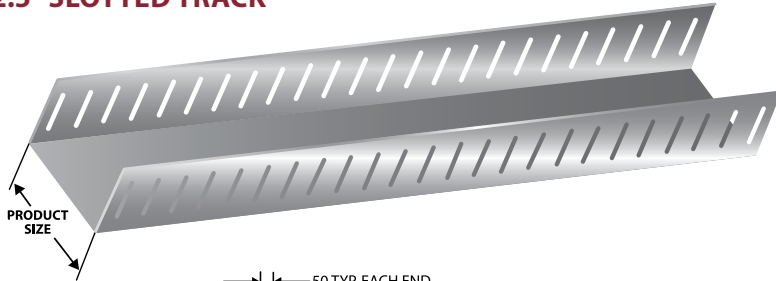

Product Sizes:

- Max Web: 8"
- Flange: 2.5"

Material Gauges

- .030" Minimum
- .071" Maximum

3" SLOTTED TRACK

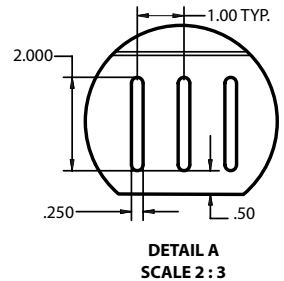
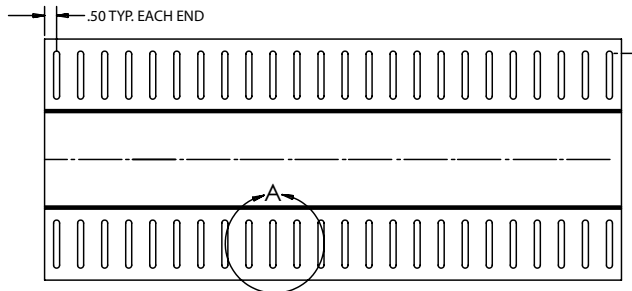
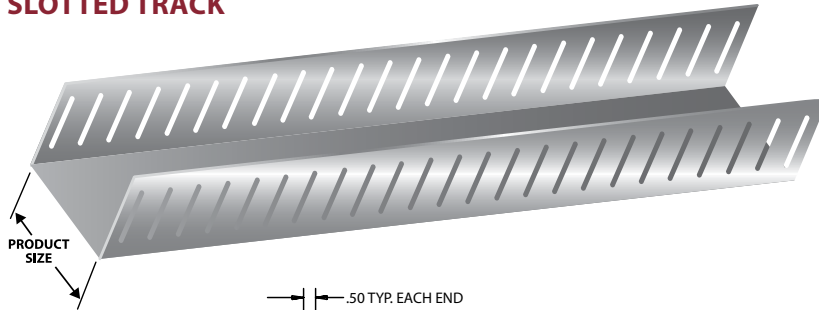

Product Sizes:

- Max Web: 8"
- Flange: 3"

Material Gauges

- .030" Minimum
- .071" Maximum

ALLOWABLE WALL HEIGHTS (ft)

Gauge		Strength	Allowable Reaction (lb/stud)	Lateral Pressure (PSF)											
Mill Thickness (mils)	Design Thickness (in)			5 PSF			10 PSF			20 PSF			30 PSF		
				Stud Spacing (in)			Stud Spacing (in)			Stud Spacing (in)			Stud Spacing (in)		
33	.0346	33	98	12	16	24	12	16	24	12	16	24	12	16	24
43	.0451	33	172	39.2	29.4	19.6	19.6	14.7	9.8	9.8	7.35	4.9	6.533	4.9	3.267
54	.0566	50	423	68.8	51.6	34.4	34.4	25.8	17.2	17.2	12.9	8.6	11.47	8.6	5.733
68	.0713	50	626	169.2	126.9	84.6	84.6	63.45	42.3	42.3	31.73	21.15	28.2	21.15	14.1
				250.4	187.8	125.2	125.2	93.9	62.6	62.6	46.95	31.3	41.73	31.3	20.87

- Note:**
1. Based on testing and analysis by Structural Testing and Research (STaR) Report No. 3160903 dated March 29, 2010 (Amended May 19, 2010).
 2. Testing based on maximum 7/8" gap between end of stud and track web.
 3. Testing based on #8 screws each leg for 33-mil track, #10 each leg for 43, 54 and 68-mil track. All screws were pan head, 0.43 inch head diameter.
 4. Loads have not been modified for duration of load.



TELLING 2.5" SLOTTED TRACK SECTION PROPERTIES

Section	Design Thickness (in)	Fy (ksi)	Gross Properties ¹							Effective Properties ^{4,5}		
			Area (in ²)	Net Area ₂ (in ²)	Wt. ³ (lb/ft)	I _{xx} (in ⁴)	R _x (in)	I _{yy} (in ⁴)	R _y (in)	S _{yy} (in ³)	S _{xy} (in ³)	M _{xy-k} (in-k)
250TAT250-30	0.0312	33	0.234	0.140	0.86	0.160	0.826	0.306	1.143	0.116	0.079	1.55
250TAT250-33	0.0346	33	0.259	0.156	0.88	0.178	0.827	0.339	1.144	0.129	0.087	1.72
250TAT250-43	0.0451	33	0.338	0.203	1.15	0.230	0.826	0.443	1.146	0.168	0.113	2.23
250TAT250-54	0.0566	50	0.424	0.254	1.44	0.287	0.824	0.565	1.155	0.213	0.141	4.22
250TAT250-68	0.0713	50	0.534	0.32	1.82	0.360	0.821	0.728	1.168	0.273	0.177	5.29
350TAT250-33	0.0346	33	0.294	0.19	1	0.198	0.821	0.687	1.528	0.286	0.138	2.73
350TAT250-43	0.0451	33	0.383	0.248	1.3	0.257	0.819	0.896	1.53	0.373	0.185	3.66
350TAT250-54	0.0566	50	0.48	0.311	1.63	0.321	0.817	1.137	1.538	0.471	0.232	6.93
350TAT250-68	0.0713	50	0.605	0.391	2.06	0.401	0.814	1.454	1.55	0.598	0.29	8.69
362TAT250-30	0.0312	33	0.269	0.175	0.92	0.181	0.820	0.667	1.575	0.281	0.126	2.49
362TAT250-33	0.0346	33	0.298	0.194	1.01	0.200	0.820	0.740	1.575	0.312	0.144	2.85
362TAT250-43	0.0451	33	0.389	0.253	1.32	0.260	0.818	0.966	1.577	0.406	0.195	3.86
362TAT250-54	0.0566	50	0.487	0.318	1.66	0.324	0.816	1.224	1.585	0.512	0.244	7.32
362TAT250-68	0.0713	50	0.614	0.4	2.09	0.406	0.813	1.565	1.597	0.65	0.306	9.17
400TAT250-30	0.0312	33	0.281	0.187	0.96	0.187	0.816	0.824	1.713	0.354	0.142	2.80
400TAT250-33	0.0346	33	0.311	0.207	1.06	0.207	0.815	0.914	1.714	0.396	0.162	3.21
400TAT250-43	0.0451	33	0.405	0.27	1.38	0.268	0.813	1.193	1.715	0.516	0.227	4.49
400TAT250-54	0.0566	50	0.509	0.339	1.73	0.335	0.811	1.511	1.723	0.65	0.284	8.51
400TAT250-68	0.0713	50	0.641	0.427	2.18	0.418	0.808	1.928	1.735	0.825	0.356	10.67
550TAT250-33	0.0346	33	0.363	0.259	1.24	0.228	0.792	1.839	2.251	0.837	0.236	4.66
550TAT250-43	0.0451	33	0.473	0.338	1.61	0.295	0.79	2.399	2.252	1.142	0.34	6.72
550TAT250-54	0.0566	50	0.594	0.424	2.02	0.368	0.788	3.029	2.259	1.436	0.43	12.87
550TAT250-68	0.0713	50	0.748	0.534	2.54	0.46	0.785	3.849	2.269	1.817	0.584	17.48
600TAT250-30	0.0312	33	0.343	0.250	1.17	0.211	0.784	2.016	2.424	0.904	0.224	4.44
600TAT250-33	0.0346	33	0.380	0.277	1.29	0.233	0.783	2.236	2.424	1.026	0.26	5.14
600TAT250-43	0.0451	33	0.496	0.36	1.69	0.303	0.781	2.916	2.425	1.407	0.378	7.47
600TAT250-54	0.0566	50	0.622	0.452	2.12	0.377	0.779	3.678	2.432	1.777	0.478	14.31
600TAT250-68	0.0713	50	0.783	0.569	2.67	0.472	0.776	4.67	2.442	2.266	0.655	19.61
800TAT250-30	0.0312	33	0.406	0.312	1.38	0.227	0.749	3.894	3.099	1.752	0.307	6.07
800TAT250-33	0.0346	33	0.450	0.346	1.53	0.252	0.748	4.318	3.099	2.003	0.358	7.07
800TAT250-43	0.0451	33	0.586	0.451	1.99	0.326	0.746	5.629	3.1	2.801	0.53	10.47
800TAT250-54	0.0566	50	0.735	0.565	2.5	0.407	0.744	7.09	3.106	3.54	0.671	20.1
800TAT250-68	0.0713	50	0.926	0.712	3.15	0.509	0.741	8.978	3.114	4.698	0.942	28.21

TELLING 3.0" SLOTTED TRACK SECTION PROPERTIES

Section	Design Thickness (in)	Fy (ksi)	Gross Properties ¹							Effective Properties ^{4,5}		
			Area (in ²)	Net Area ² (in ²)	Wt. ³ (lb/ft)	I _x (in ⁴)	R _x (in)	I _y (in ⁴)	R _y (in)	I _y (in ⁴)	S _y (in ³)	May (in-k)
250TAT300-30	0.0312	33	0.265	0.140	0.902	0.262	0.993	0.359	1.163	0.188	0.104	1.711
250TAT300-33	0.0346	33	0.294	0.156	1.00	0.290	0.993	0.398	1.164	0.215	0.120	1.974
250TAT300-43	0.0451	33	0.383	0.203	1.30	0.376	0.991	0.521	1.166	0.306	0.174	2.874
250TAT300-54	0.0566	50	0.480	0.254	1.63	0.470	0.989	0.664	1.176	0.397	0.224	6.712
250TAT300-68	0.0713	50	0.605	0.320	2.06	0.589	0.987	0.856	1.190	0.559	0.321	9.616
350TAT300-33	0.0346	33	0.329	0.190	1.12	0.324	0.992	0.799	1.560	0.457	0.190	3.139
350TAT300-43	0.0451	33	0.428	0.248	1.46	0.420	0.991	1.044	1.562	0.648	0.277	4.563
350TAT300-54	0.0566	50	0.537	0.311	1.83	0.525	0.989	1.324	1.570	0.833	0.354	10.601
350TAT300-68	0.0713	50	0.676	0.391	2.30	0.657	0.986	1.695	1.583	1.150	0.497	14.887
362TAT300-30	0.0312	33	0.300	0.175	1.02	0.296	0.992	0.776	1.607	0.414	0.162	2.668
362TAT300-33	0.0346	33	0.333	0.195	1.13	0.327	0.992	0.861	1.608	0.491	0.197	3.256
362TAT300-43	0.0451	33	0.434	0.253	1.48	0.425	0.990	1.124	1.610	0.701	0.291	4.795
362TAT300-54	0.0566	50	0.544	0.318	1.85	0.531	0.988	1.425	1.619	0.901	0.372	11.134
362TAT300-68	0.0713	50	0.685	0.400	2.33	0.665	0.985	1.823	1.631	1.242	0.521	15.604
400TAT300-30	0.0312	33	0.312	0.187	1.06	0.305	0.989	0.956	1.751	0.507	0.179	2.957
400TAT300-33	0.0346	33	0.346	0.208	1.18	0.338	0.989	1.061	1.751	0.601	0.219	3.609
400TAT300-43	0.0451	33	0.451	0.270	1.53	0.439	0.987	1.384	1.753	0.878	0.334	5.517
400TAT300-54	0.0566	50	0.565	0.339	1.92	0.548	0.985	1.754	1.761	1.126	0.427	12.795
400TAT300-68	0.0713	50	0.712	0.427	2.42	0.686	0.982	2.239	1.774	1.544	0.596	17.831
550TAT300-33	0.0346	33	0.398	0.259	1.35	0.374	0.969	2.112	2.304	1.156	0.303	5.002
550TAT300-43	0.0451	33	0.518	0.338	1.76	0.485	0.968	2.755	2.306	1.795	0.511	8.430
550TAT300-54	0.0566	50	0.650	0.424	2.21	0.606	0.965	3.479	2.313	2.320	0.664	19.883
550TAT300-68	0.0713	50	0.819	0.534	2.79	0.758	0.962	4.424	2.324	3.175	0.930	27.853
600TAT300-30	0.0312	33	0.374	0.250	1.27	0.347	0.962	2.307	2.483	1.168	0.272	4.491
600TAT300-33	0.0346	33	0.415	0.277	1.41	0.384	0.962	2.559	2.483	1.383	0.331	5.463
600TAT300-43	0.0451	33	0.541	0.360	1.84	0.498	0.960	3.337	2.484	2.144	0.557	9.184
600TAT300-54	0.0566	50	0.679	0.452	2.31	0.622	0.957	4.212	2.492	2.770	0.723	21.652
600TAT300-68	0.0713	50	0.855	0.569	2.91	0.778	0.955	5.351	2.502	3.883	1.055	31.582
800TAT300-30	0.0312	33	0.437	0.312	1.49	0.376	0.928	4.407	3.177	2.121	0.365	6.029
800TAT300-33	0.0346	33	0.484	0.346	1.65	0.416	0.927	4.887	3.177	2.512	0.444	7.320
800TAT300-43	0.0451	33	0.631	0.451	2.15	0.540	0.925	6.372	3.178	3.880	0.738	12.173
800TAT300-54	0.0566	50	0.792	0.565	2.69	0.675	0.923	8.028	3.184	5.001	0.957	28.659
800TAT300-68	0.0713	50	0.997	0.712	3.39	0.844	0.920	10.171	3.194	7.471	1.551	46.447

Notes: 1. Gross properties are based on the full section away from flange slots. 2. Net area is based on the section through the flange slots. 3. Weight is nominal weight of the gross section, not reduced for flange slots. 4. Effective properties are calculated in accordance with the 2007 NASPEC with 2010 Supplement (AISI S100-07/S2-10). For effective flange widths, the compression flange (before local buckling) is taken as the portion of the flange between the web and any steel beyond the slot is considered absent). The tension flange is taken as the net flange at the slots. 5. Cold-work of forming has not been considered for effective properties. 6. Web width-to-thickness ratio exceeds 200. Web stiffeners are required at points of concentrated loads or reactions. 7. IBC 2006, 2009, and 2012 compliant.

ACCESSORIES - AREA SEPARATION WALL, H-Stud, C Track

Product Data:

- 2-hour rated vertical wall assemblies that provide fire-resistant protection between adjacent living units
- Area Separation Walls are also referred to as party walls, firewalls, multi-family walls and H-Stud assemblies

Uses:

- Non-load bearing, 2-hour rated vertical wall assemblies that provide fire-resistant protection between adjacent living units in apartment buildings, condominiums and townhouses
- Assembled between two independent walls to form a commonly shared party wall that extends from the foundation through the roofline
- The walls are assembled with two-1" thick gypsum panel liners vertically installed between 2" H-Studs spaced 24"
- C-Runners or H-Tracks are installed at the top and bottom of the walls and back-to-back between vertically stacked panels.
- Overall stacked area separation wall assembly cannot exceed 50 feet

Aluminum Angle Clip

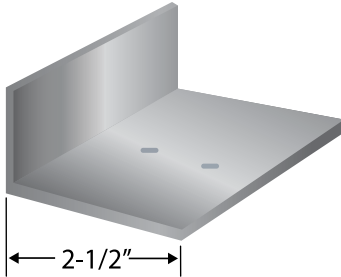

C-Track, Cap, Edge or End Closure

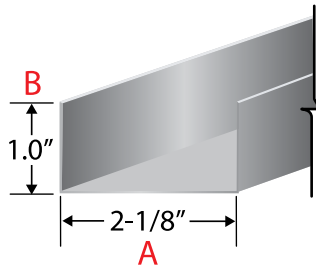

H-Stud, 25-Gauge

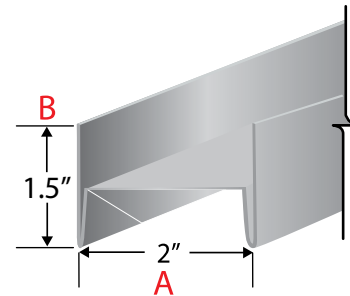

C TRACK PRODUCT OFFERING

Section	Web (A) inches	Leg (B) inches	Coatings
213ASW-AST100-18	2.125"	1.0"	G40 standard. G60 & G90 with upcharge

TRACK SECTIONAL PROPERTIES

Section	Design Thickness (in)	Min Thickness (in)	Fy (ksi)	Weight (lb/ft)	Area (in ²)	Ixx (in ⁴)	Rx (in)	Iyy (in ⁴)	Ry (in)
213ASW-AST100-18	0.0188"	0.0179"	33	0.26	0.075	0.054	0.847	0.008	0.319

H STUD PRODUCT OFFERING

Section	Web (A) inches	Flange (B) inches	Double Wall Flange (C) inches	Hem Lip (D) inches	Coatings
200ASW-HS200	2.0"	1.50"	0.75"	0.0625" min	G40 standard G60 & G90 with upcharge

H STUD SECTIONAL PROPERTIES

Section	Design Thickness (in)	Min Thickness (in)	Fy (ksi)	Weight (lb/ft)	Area (in ²)	Ixx (in ⁴)	Rx (in)	Iyy (in ⁴)	Ry (in)
200ASW-HS200	0.0188"	0.0179"	33	0.70	0.205	0.185	0.952	0.118	0.760

C Track

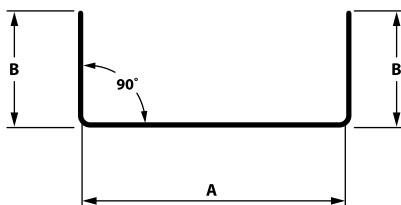

H Stud

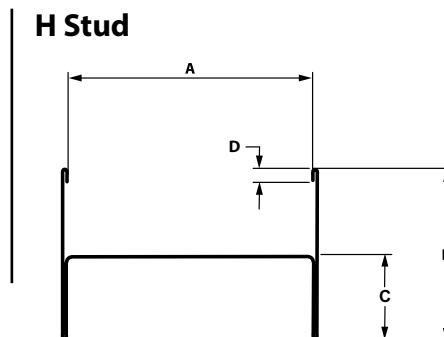

ACCESSORIES - SHAFTWALL SYSTEM: CT STUD & J TRACK

Shaftwall systems are used to aid in the construction of elevator shafts, mechanical shafts, stairwells, air return shafts and horizontal membranes. The system is designed to use with 1" gypsum board. Telling's shaftwall is available in 2 1/2", 4", or 6" sizes. Shaftwall is available in 18, 33 and 40 mil thicknesses.

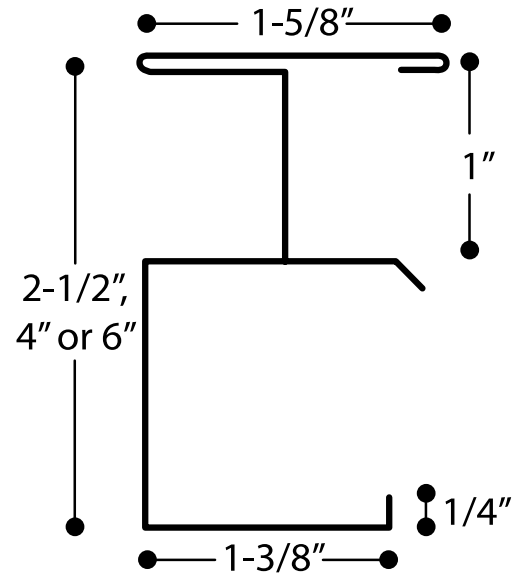

CT Stud Product Offering

Section	Web (in)	Min Thickness (in)	Design Thickness (in)	Fy (ksi)
CT-18	2.5", 4.0", 6.0"	0.0179	0.0188	33
CT-33	2.5", 4.0", 6.0"	0.0329	0.0346	33
CT-40	2.5", 4.0", 6.0"	0.0380	0.0400	33

CT Stud Section Properties

Section	Min Thickness (in)	Design Thickness (in)	Fy (ksi)	Weight (lb/ft)	Area (in ²)	Ixx (in ⁴)	Sx(C) (in ³)	Sx(T) (in ³)
250CT-18	0.0179"	0.0188"	33	0.47	0.118	0.132	0.095	0.118
400CT-18	0.0179"	0.0188"	33	0.58	0.015	0.374	0.171	0.207
600CT-18	0.0179"	0.0188"	33	0.72	0.181	0.957	0.299	0.347
250CT-33	0.0329"	0.0346"	33	0.82	0.218	0.242	0.175	0.217
400CT-33	0.0329"	0.0346"	33	1.02	0.267	0.687	0.341	0.380
600CT-33	0.0329"	0.0346"	33	1.26	0.333	1.759	0.543	0.637
250CT-40	0.0380"	0.0400"	33	0.99	0.291	0.273	0.253	0.192
400CT-40	0.0380"	0.0400"	33	1.19	0.351	0.811	0.476	0.353
600CT-40	0.0380"	0.0400"	33	1.47	0.431	2.142	0.827	0.628

CT Stud & J Track Limiting Wall Heights

Limiting Wall Heights for CT Studs & J Track Shaftwall 1-Hour Fire Rated Assemblies

Section	Design Thickness (in)	5 psf				7.5 psf				10 psf			
		L/120	L/180	L/240	L/360	L/120	L/180	L/240	L/360	L/120	L/180	L/240	L/360
250CT-18	0.0188"	11'7"f	11'- 4"	10'- 6"	9'- 0"	9'- 5"f	9'5"f	8'11"		8'2"f	8'2"f	7'10"	
400CT-18	0.0188"	14'6"f	14'6"f	13- 9	12- 1	11-10 f	11-10 f	11-10f	10-5	9-3s	9-3s	9-3s	9-3s
600CT-18	0.0188"	16'11"f	16- 11f	16- 11f	16- 3	13-10 f	13-10 f	13-10f	13-10f	12-0f	12-0f	12-0f	12-0f
250CT-33	0.0346"	15'9"	13- 9	12- 6	10- 11	13- 9	12-0	10-11	9-6	12-6	10-11		8-7
400CT-33	0.0346"	21'7"	18- 10	17- 2	15- 0	18-9f	16-6	15-0	13-1	16-2f	15-0	13-7	11-10
600CT-33	0.0346"	27'10"f	25- 3	22- 11	20- 1	22-9f	22-1	20-1	17-6	19-5f	19-5f	18-3	15-11
250CT-40	0.0400"	16'11"	14- 9	13- 5	11- 9	14-9	12-11	11-9	10-2	13-5	11-9	10-7	9-2
400CT-40	0.0400"	23'4"	20- 4	18- 6	16- 2	20-4	17-9	16-2	14-1	18-6	16-2	14-8	12-10
600CT-40	0.0400"	30'11"	27- 1	24- 8	21- 7	27-1	23-9	21-7	18-11	24-7f	21-7	19-8	17-3

NOTES:

- Allowable composite limiting heights are calculated using ICC-ES-AC86-2012
- "f" indicates flexural stress controls the allowable wall height
- "s" indicates the end reaction controls the allowable wall height
- Wall Construction was: Type X 5/8" thick Gypsum board, & #6 screws
- Stud Spacing was 24" on center
- 600CT-33 and 600CT-40 assemblies require a 6 in screw spacing for the gypsum board along the top & bottom track.

ACCESSORIES - SHAFTWALL SYSTEM: J TRACK

Shaftwall systems are used to aid in the construction of elevator shafts, mechanical shafts, stairwells, air return shafts and horizontal membranes. The system is designed to use with 1" gypsum board. Telling's shaftwall is available in 2 1/2", 4", or 6" sizes. Shaftwall is available in 18, 33 and 40 mil thicknesses.

J Track Product Offering

Section	Web (in)	Flange (in)	Min Thickness (in)	Design Thickness (in)	Fy (ksi)
JT-18	2.5", 4.0", 6.0"	2.25" & 3.0"	0.0179	0.0188	33
JT-33	2.5", 4.0", 6.0"	2.25" & 3.0"	0.0329	0.0346	33

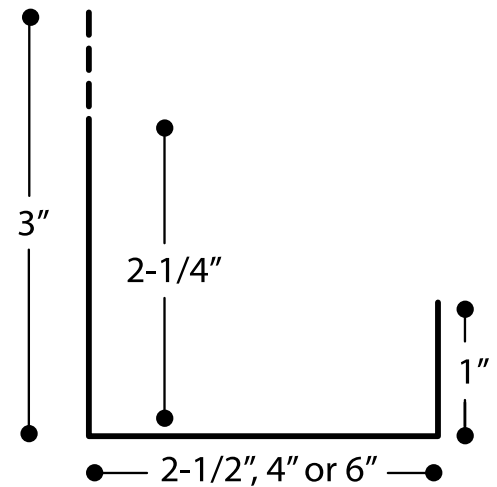

J Track Sectional Properties

Section	Min Thickness (in)	Design Thickness (in)	Fy (ksi)	Weight (lb/ft)	Area (in ²)	I _{xx} (in ⁴)	R _x (in)	I _{yy} (in ⁴)	R _y (in)
250JT225-18	0.0179	0.0188"	33	0.3681	0.1082	0.1193	1.05	0.0471	0.6601
400JT225-18	0.0179	0.0188"	33	0.464	0.1364	0.3404	1.5799	0.0532	0.6247
600JT225-18	0.0179	0.0188"	33	0.592	0.174	0.878	2.2466	0.0583	0.5787
250JT300-18	0.0179	0.0188"	33	0.4161	0.1223	0.1322	1.0399	0.1025	0.9155
400JT300-18	0.0179	0.0188"	33	0.512	0.1505	0.3772	1.5834	0.1158	0.8774
600JT300-18	0.0179	0.0188"	33	0.64	0.1881	0.9689	2.2697	0.1274	0.823
250JT225-33	0.0329	0.0346"	33	0.6765	0.1988	0.22	1.052	0.086	0.6575
400JT225-33	0.0329	0.0346"	33	0.8531	0.2507	0.6269	1.5813	0.097	0.622
600JT225-33	0.0329	0.0346"	33	1.0886	0.3199	1.6159	2.2474	0.1061	0.576
250JT300-33	0.0329	0.0346"	33	0.7648	0.2248	0.244	1.0419	0.1874	0.9131
400JT300-33	0.0329	0.0346"	33	0.9414	0.2767	0.695	1.5849	0.2117	0.8748
600JT300-33	0.0329	0.0346"	33	1.1769	0.3459	1.7835	2.2708	0.2328	0.8204

SHAFTWALL SYSTEM: JL CORNER

Shaftwall systems are used to aid in the construction of elevator shafts, mechanical shafts, stairwells, air return shafts and horizontal membranes. The system is designed to use with 1" gypsum board. MBA's shaftwall is available in 2 1/2", 4", or 6" sizes. Shaftwall is available in 18 and 33 mil thicknesses.

J-L Corner Product Offering

Section	Web (in)	Flange (in)	Min Thickness (in)	Design Thickness (in)	Fy Yield Stress (ksi)	Notes
JL-18	2.5", 4.0", 6.0"	2.5", 4.0", 6.0"	0.0179"	0.0188"	33	12' max length
JL-33	2.5", 4.0", 6.0"	2.5", 4.0", 6.0"	0.0329"	0.0346"	33	12' max length
JL-40	2.5", 4.0", 6.0"	2.5", 4.0", 6.0"	0.0038"	0.0400"	33	12' max length

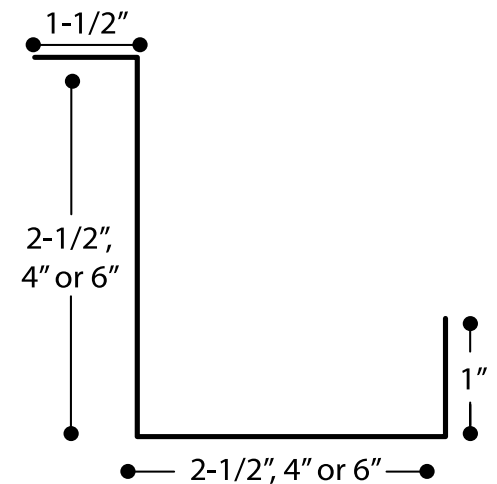

Recommendations

- Use a fastening plate to secure the J track whenever fasteners are closer than 4" to the edge. Setting the plate at the time of concrete construction will avoid spalling by mechanical fasteners.
- Cut C-T studs 3/4" less than the height of the opening.
- Cut 1" shaftliner panel 3/4" less than the height of the opening.
- In structural steel-frame construction, install J track sections before applying spray-on fireproofing.
- Items to be anchored to the wall (cabinets, sinks, handrails, etc.) should be fastened to the C-T or to plates secured behind or between layers of 1/2" Type C gypsum board.
- Joint compounds should be applied at ambient temperatures above 50°F (10°C) with adequate ventilation.
- Use Type S screws for 25-gauge steel framing. Use Type S-12 screws for 20-gauge (or heavier) steel framing.
- It is important that the job structural engineer approves the type, size and maximum spacing of track fasteners to meet the design load requirements.

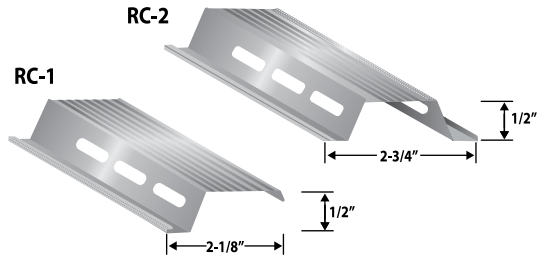

Product Data:

- RC-1: Single Leg
- RC-2: Double Leg
- Gauge: Standard 25 gauge conforming to ASTM A-653 and C-645
- Lengths: 12' 0" stock length
- RC-1: Screw attachment, one side only
- RC-2: Screw attachment, both sides

Uses:

- Used as cross furring members for resilient attachment of gypsum wallboard or lath on ceilings and partitions
- Decreased sound transmission through wall partitions and ceilings up to 13%

Product	Length	Wt./Ft.	Pcs./Ctn.	Ft./Ctn.
RC-1	12'	0.20	40	480
RC-2		0.24		

Supreme Tested Assemblies

All acoustical data was independently tested by Riverbank Acoustical Laboratories. Riverbank Acoustical is a nationally recognized company accredited by the National Institute of Standards and Technology (NIST) through the National Voluntary Laboratory Accreditation Program (NVLAP).



Partition Specifications

Partition Type	Side A	Side B	Gypsum Type	Insulation Type	Stud Spacing	STC Rating
1	1 layer	1 layer	5/8" Type X	-	24" oc	38
2	1 layer	1 layer	5/8" Type X	R-11 insulated	24" oc	47
3	1 layer	1 layer on RC-1	5/8" Type X	R-11 insulated	24" oc	52
4	2 layers	2 layers on RC-1	5/8" Type X	R-11 insulated	24" oc	61

Typical RC-1 Installation Instructions for Walls

- Bottom RC-1 installed with mounting leg turned up, spaced 2" up from top track leg.
- Top RC-1 installed with mounting leg turned down, spaced 6" down from track leg.
- Middle RC-1 installed with mounting leg turned down, spaced 24" apart.
- Please reference Gypsum Association's GA-216 guidelines.

Typical RC-1 Installation Instructions for Ceilings

- When RC-1 is installed on a ceiling, it should be installed perpendicular to the joists.
- RC-1 should be installed on ceilings with the open side facing the same direction across the entire ceiling.
- RC-1 on ceilings should be installed with maximum of 6" spacing out from a wall.
- 16" OC joist spacing use 24" RC-1 spacing. 24" OC joist spacing use 16" RC-1 spacing.
- RC-1 can be overlapped at a support location with a minimum of 4" overlap.
- No more than two 5/8" gypsum boards should be fastened to an RC-1 channel with a maximum load of 5 lbs per SF.

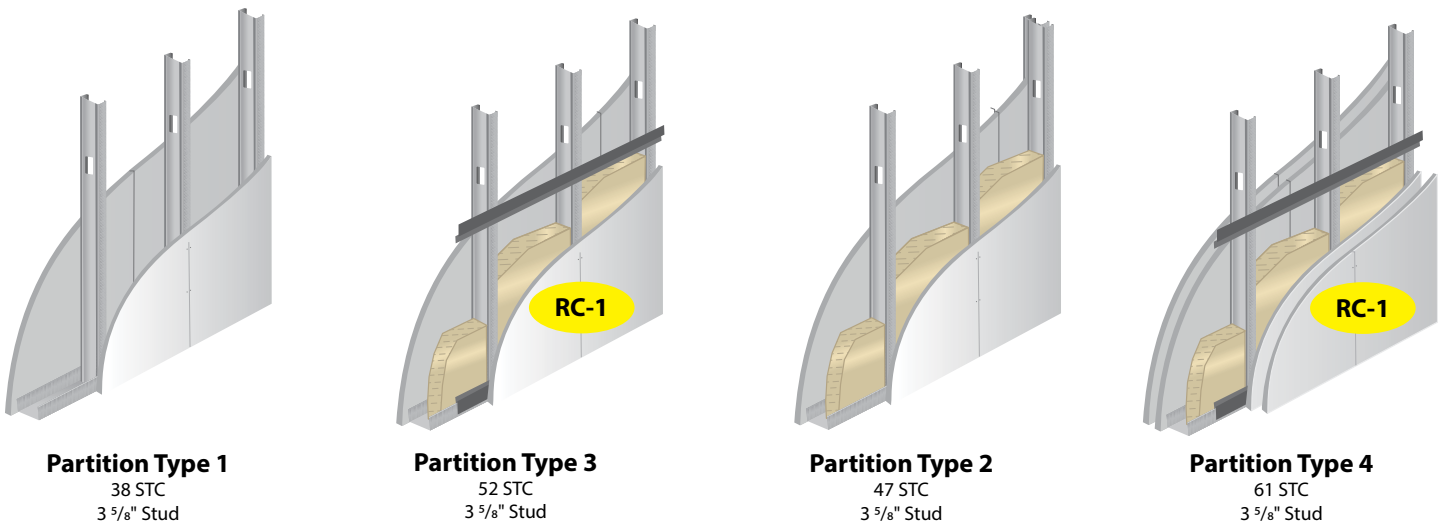

Partition Type 1
38 STC
3 5/8" Stud

Partition Type 3
52 STC
3 5/8" Stud

Partition Type 2
47 STC
3 5/8" Stud

Partition Type 4
61 STC
3 5/8" Stud

ACCESSORIES - (DWFC) DRYWALL FURRING CHANNEL

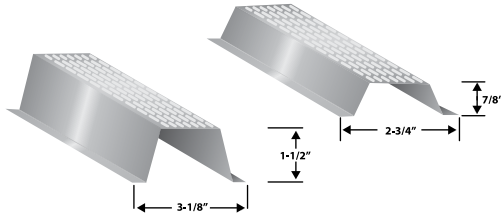

Product Data:

- Available in 7/8" and 1-1/2" sizes.
- Gauge: Standard 25 through 12 gauges.
- Lengths: 12' 0": stock length, (other lengths available).
- Constult Telling Industries' light gauges structural framing and accessories brochure for structural properties and span tables

Uses:

- Conventional accessory components for use in furring out ceilings and masonry walls. Knurled face prevents screw "ride" when attaching gypsum wallboard.
- 1-1/2" DWFC is economical with respect to furring walls with electrical boxes, (no need to set into concrete).

DRYWALL FURRING CHANNELS (DWFC): SECTION PROPERTIES

Section	50Fy (ksi)	Design Thickness (in)	Gross Properties						Effective Properties		
			Area (in ²)	Weight (lb/ft)	Ix (in ⁴)	Rx (in)	Iy (in ⁴)	Ry (in)	Ix (in ⁴)	Sx (in ³)	Ma (Ft-lb)
DWFC088-18	33	0.0188	0.070	0.239	0.009	0.356	0.035	0.710	0.009	0.016	26.4
DWFC088-30	33	0.0312	0.115	0.391	0.014	0.353	0.058	0.710	0.014	0.031	50.5
DWFC088-43	33	0.0451	0.162	0.550	0.020	0.348	0.082	0.711	0.020	0.042	69.2
DWFC088-54	50	0.0566	0.197	0.669	0.023	0.345	0.099	0.711	0.023	0.050	124.9
DWFC150-18	33	0.0188	0.094	0.320	0.031	0.575	0.047	0.705	0.030	0.034	56.6
DWFC150-30	33	0.0312	0.154	0.525	0.050	0.571	0.077	0.705	0.050	0.064	105.3
DWFC150-43	33	0.0451	0.219	0.745	0.070	0.565	0.109	0.705	0.070	0.089	146.3
DWFC150-54	50	0.0566	0.269	0.914	0.084	0.561	0.134	0.705	0.084	0.107	267.2

- Notes:
1. Properties based on the 2007 NASPEC
 2. Design thickness used for determination of properties. Minimum delivered thickness must be no less than 95% of design thickness.
 3. For deflection calculations, use effective Ixx. Effective Ixx based on Procedure 1 of NASPEC
 4. Effective properties are given as the minimum value for positive or negative bending

DRYWALL FURRING CHANNEL (DWFC) ALLOWABLE CEILING SPANS - L/240

Section	Fy (ksi)	Spans	4 psf Spacing (in) oc			Uniform Load 6 psf Spacing (in) oc			13 psf Spacing (in) oc		
			12	16	24	12	16	24	12	16	24
			DWFC088-18	33	Single	5'-2"	4'-9"	4'-1"	4'-6"	4'-1"	3'-7"
		Multiple	6'-5"	5'-10"	5'-1"	5'-7"	5'-1"	4'-2"	4'-0"	3'-6"	2'-9"
DWFC088-30	33	Single	6'-5"	5'-7"	4'-11"	5'-5"	4'-11"	4'-3"	4'-2"	3'-9"	3'-4"
		Multiple	6'-2"	6'-11"	6'-1"	6'-8"	6'-1"	5'-3"	5'-2"	4'-8"	3'-11"
DWFC088-43	33	Single	7'-7"	6'-3"	5'-5"	6'-0"	5'-5"	4'-9"	4'-7"	4'-2"	3'-8"
		Multiple	6'-10"	7'-8"	6'-9"	7'-5"	6'-9"	5'-10"	5'-9"	5'-2"	4'-6"
DWFC088-54	50	Single	8'-6"	6'-7"	5'-9"	6'-4"	5'-9"	5'-0"	4'-11"	4'-5"	3'-11"
		Multiple	9'-0"	8'-2"	7'-2"	7'-10"	7'-2"	6'-3"	6'-1"	5'-6"	4'-10"
DWFC150-18	33	Single	7'-11"	7'-2"	6'-3"	6'-11"	6'-3"	5'-6"	5'-4"	4'-10"	4'-2"
		Multiple	9'-9"	8'-10"	7'-5"	8'-6"	7'-5"	5'-11"	5'-7"	4'-9"	3'-8"
DWFC150-30	33	Single	9'-5"	8'-6"	7'-5"	8'-2"	7'-5"	6'-6"	6'-4"	5'-9"	5'-0"
		Multiple	11'-7"	10'-6"	9'-2"	10'-2"	9'-2"	8'-0"	7'-10"	7'-0"	5'-8"
DWFC150-43	33	Single	10'-6"	9'-6"	8'-4"	9'-2"	8'-4"	7'-3"	7'-1"	6'-5"	5'-7"
		Multiple	12'-11"	11'-9"	10'-3"	11'-4"	10'-3"	9'-0"	8'-9"	7'-11"	6'-8"
DWFC150-54	50	Single	11'-2"	10'-1"	8'-10"	9'-9"	8'-10"	7'-9"	7'-6"	6'-10"	6'-0"
			13'-9"	12'-6"	10'-11"	12'-0"	10'-11"	9'-7"	9'-4"	8'-5"	7'-5"

DRYWALL FURRING CHANNEL (DWFC) ALLOWABLE CEILING SPANS - L/360

Section	Fy (ksi)	Spans	4 psf Spacing (in) oc			Uniform Load 6 psf Spacing (in) oc			13 psf Spacing (in) oc		
			12	16	24	12	16	24	12	16	24
			DWFC088-18	33	Single	4'-6"	4'-1"	3'-7"	4'-0"	3'-7"	3'-2"
		Multiple	5'-7"	5'-1"	4'-5"	4'-11"	4'-5"	3'-11"	3'-9"	3'-5"	2'-9"
DWFC088-30	33	Single	5'-5"	4'-11"	4'-3"	4'-8"	4'-3"	3'-9"	3'-8"	3'-4"	2'-11"
		Multiple	6'-8"	6'-1"	5'-3"	5'-10"	5'-3"	4'-7"	4'-6"	4'-1"	3'-7"
DWFC088-43	33	Single	6'-0"	5'-5"	4'-9"	5'-3"	4'-9"	4'-2"	4'-0"	3'-8"	3'-2"
		Multiple	7'-5"	6'-9"	5'-10"	6'-6"	5'-10"	5'-2"	5'-0"	4'-6"	4'-0"
DWFC088-54	50	Single	6'-4"	5'-9"	5'-0"	5'-7"	5'-0"	4'-5"	4'-3"	3'-11"	3'-5"
		Multiple	7'-10"	7'-2"	6'-3"	6'-10"	6'-3"	5'-5"	5'-4"	4'-10"	4'-2"
DWFC150-18	33	Single	6'-11"	6'-3"	5'-6"	6'-0"	5'-6"	4'-9"	4'-8"	4'-3"	3'-8"
		Multiple	8'-6"	7'-9"	6'-9"	7'-5"	6'-9"	5'-11"	5'-7"	4'-9"	3'-8"
DWFC150-30	33	Single	8'-2"	7'-5"	6'-6"	7'-2"	6'-6"	5'-8"	5'-6"	5'-0"	4'-5"
		Multiple	10'-2"	9'-2"	8'-0"	8'-10"	8'-0"	7'-0"	6'-10"	6'-3"	5'-5"
DWFC150-43	33	Single	9'-2"	8'-4"	7'-3"	8'-0"	7'-3"	6'-4"	6'-2"	5'-7"	4'-11"
		Multiple	11'-4"	10'-3"	9'-0"	9'-11"	9'-0"	7'-10"	7'-8"	6'-11"	6'-1"
DWFC150-54	50	Single	9'-9"	8'-10"	7'-9"	8'-6"	7'-9"	6'-9"	6'-7"	6'-0"	5'-3"
			12'-0"	10'-11"	9'-7"	10'-6"	9'-7"	8'-4"	8'-2"	7'-5"	6'-5"

- Notes:
1. Single spans taken as the minimum span based on moment, shear, web crippling or deflection
 2. Multiple spans indicate two or more equal, continuous spans with span length measured support to support.
 3. Multiple spans taken as the minimum span based on moment, shear, web crippling, deflection combined bending and shear or combined and web crippling
 4. Web crippling values based on 1" bearing at end and interior supports.

ACCESSORIES - (CRC) COLD-ROLLED CHANNEL

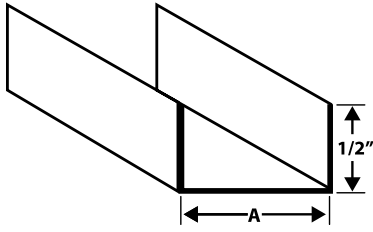

Product Data:

- Available in galvanized steel meeting ASTM A-1003 or hot-dipped galvanized steel meeting ASTM A-653, G60.
- Lengths: 16' stock length. (Other lengths available)

Uses:

- Bridging, (lateral support) in walls carrying axial and/or wind loads.
- Bracing studs at door bucks and furring for ceilings.
- Used in conjunction with metal lath and plaster in partitions, ceilings, column and beam enclosures, etc.

U-CHANNEL (CRC) SECTION PROPERTIES

Section	Design Thickness (in)	Gross						Effective Properties 33 ksi			
		Area (in ²)	Weight (lb/ft)	I _x (in ⁴)	R _x (in)	I _y (in ⁴)	R _y (in)	I _x (in ⁴)	S _x (in ³)	Ma (in-k)	Va (lb)
CRC-075	0.0566	0.087	0.30	0.007	0.288	0.002	0.155	0.007	0.019	0.45	315
CRC-150	0.0566	0.129	0.44	0.039	0.547	0.003	0.144	0.039	0.052	1.22	840
CRC-200	0.0566	0.157	0.54	0.079	0.079	0.003	0.136	0.079	0.079	1.87	1190
CRC-250	0.0566	0.186	0.63	0.139	0.866	0.003	0.128	0.139	0.111	2.64	1540

- Notes:
1. Minimum deliverable base metal thickness is 95% of design thickness.
 2. Inside bend radius taken as 3/32"
 3. Effective properties based on F_y = 33ksi
 4. For deflection calculations, use the effective moment of inertia

ALLOWABLE U-CHANNEL (CRC) CEILING SPANS - L/240

Section	Spans	4 psf					6 psf					13 psf					15 psf				
		Channel Spacing (in) o.c.					Channel Spacing (in) o.c.					Channel Spacing (in) o.c.					Channel Spacing (in) o.c.				
		24	36	48	60	72	24	36	48	60	72	24	36	48	60	72	24	36	48	60	72
CRC-075	Single	3'11"	3'5"	3'1"	2'10"	2'8"	3'5"	3'0"	2'8"	2'6"	2'4"	2'7"	2'4"	2'1"	1'11"	1'9"	2'6"	2'2"	2'0"	1'10"	1'8"
	Multiple	4'10"	4'2"	3'10"	3'7"	3'4"	4'2"	3'8"	3'4"	3'1"	2'10"	3'3"	2'9"	2'4"	2'1"	1'11"	3'1"	2'7"	2'2"	2'0"	1'9"
CRC-150	Single	5'6"	4'10"	4'5"	4'1"	3'10"	4'10"	4'3"	3'10"	3'7"	3'5"	3'9"	3'3"	3'0"	2'9"	2'7"	3'7"	3'2"	2'10"	2'7"	2'5"
	Multiple	7'1"	6'2"	5'8"	5'3"	4'11"	6'2"	5'5"	4'11"	4'7"	4'4"	4'10"	4'2"	3'9"	3'4"	3'0"	4'7"	4'0"	3'6"	3'1"	2'9"
CRC-200	Single	5'10"	5'1"	4'8"	4'4"	4'1"	5'1"	4'6"	4'1"	3'10"	3'7"	4'0"	3'6"	3'2"	3'0"	2'10"	3'10"	3'4"	3'1"	2'10"	2'8"
	Multiple	7'5"	6'6"	5'11"	5'6"	5'2"	6'6"	5'8"	5'2"	4'10"	4'7"	5'1"	4'5"	4'0"	3'9"	3'6"	4'10"	4'3"	3'10"	3'7"	3'2"
CRC-250	Single	6'1"	5'4"	4'10"	4'6"	4'3"	5'4"	4'8"	4'3"	4'0"	3'9"	4'2"	3'8"	3'4"	3'1"	2'11"	4'0"	3'6"	3'2"	3'0"	2'10"
		7'9"	6'9"	6'2"	5'9"	5'5"	6'9"	5'11"	5'5"	5'0"	4'9"	5'3"	4'7"	4'3"	3'11"	3'9"	5'0"	4'5"	4'0"	3'9"	3'7"

ALLOWABLE U-CHANNEL (CRC) CEILING SPANS - L/360

Section	Spans	4 psf					6 psf					13 psf					15 psf				
		Channel Spacing (in) o.c.					Channel Spacing (in) o.c.					Channel Spacing (in) o.c.					Channel Spacing (in) o.c.				
		24	36	48	60	72	24	36	48	60	72	24	36	48	60	72	24	36	48	60	72
CRC-075	Single	3'5"	3'0"	2'8"	2'6"	2'4"	3'0"	2'7"	2'4"	2'2"	2'1"	2'4"	2'0"	1'10"	1'8"	1'7"	2'2"	1'11"	1'9"	1'7"	1'6"
	Multiple	4'2"	3'8"	3'4"	3'1"	2'11"	3'8"	3'2"	2'11"	2'8"	2'7"	2'10"	2'6"	2'3"	2'1"	1'11"	2'8"	2'4"	2'2"	2'0"	1'9"
CRC-150	Single	5'6"	4'10"	4'5"	4'1"	3'10"	4'10"	4'3"	3'10"	3'7"	3'5"	3'9"	3'3"	3'0"	2'9"	2'7"	3'7"	3'2"	2'10"	2'7"	2'5"
	Multiple	7'1"	6'2"	5'8"	5'3"	4'11"	6'2"	5'5"	4'11"	4'7"	4'4"	4'10"	4'2"	3'9"	3'4"	3'0"	4'7"	4'0"	3'6"	3'1"	2'9"
CRC-200	Single	5'10"	5'1"	4'8"	4'4"	4'1"	5'1"	4'6"	4'1"	3'10"	3'7"	4'0"	3'6"	3'2"	3'0"	2'10"	3'10"	3'4"	3'1"	2'10"	2'8"
	Multiple	7'5"	6'6"	5'11"	5'6"	5'2"	6'6"	5'8"	5'2"	4'10"	4'7"	5'1"	4'5"	4'0"	3'9"	3'6"	4'10"	4'3"	3'10"	3'7"	3'2"
CRC-250	Single	6'1"	5'4"	4'10"	4'6"	4'3"	5'4"	4'8"	4'3"	4'0"	3'9"	4'2"	3'8"	3'4"	3'1"	2'11"	4'0"	3'6"	3'2"	3'0"	2'10"
		7'9"	6'9"	6'2"	5'9"	5'5"	6'9"	5'11"	5'5"	5'0"	4'9"	5'3"	4'7"	4'3"	3'11"	3'9"	5'0"	4'5"	4'0"	3'9"	3'7"

- Notes:
1. Multiple span indicates two or more equal spans with channel continuous over interior supports.
 2. End and interior bearing length = 0.75'. Web stiffeners are not required.
 3. Listed spans are based on unbraced compression flanges.
 4. Moment of inertia for deflection is calculated at the maximum service level stress for the span and load listed. Note that this value may be higher than the effective I_{xx} listed in section property tables.

(ZFC) Z-FURRING CHANNEL Product Data:

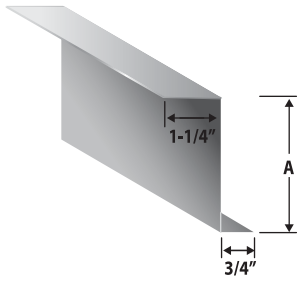

- Available in hot-dipped galvanized steel conforming to ASTM A-653 and C-645
- Gauges: Standard 25 gauge, (available in 20, 18, and 16 gauge upon request)
- Lengths: Standard 10'0" and 8'6" lengths, (other lengths available upon request)

Uses:

- Designed to accommodate the installation of rigid insulation board while providing an attachment for drywall or other facing materials to the interior side of masonry or monolithic concrete walls

Product	(A) in. Size	25 Ga. Wt./Ft.
Z-100	1.00	0.195
Z-150	1.50	0.225
Z-200	2.00	0.260

(RT) REVEAL TRIM

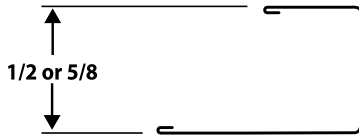

Product Data:

- An economical steel channel
- No joint cement required

Uses:

- Provides edge protection around doors and windows or any partition junction openings

Product	Size Depth	Length (ft.)	Pcs./Ctn.	Ft./Ctn.
RT-50, RT-62	1/2" & 5/8"	8', 10'	63, 50	504, 500

Custom lengths and UPS labeling available upon request

093 EXPANSION CONTROL JOINT

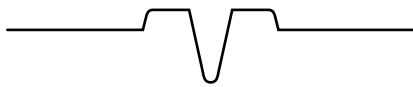

Product Data:

- Manufacturing from the highest quality pure zinc coil stock for superior corrosion resistance
- Fits standard 1/4" openings

Uses:

- Product is excellent for interior or exterior applications

Product	Length (ft.)	Pcs./Ctn.	Ft./Ctn.
093	10'	25	250

(CLT) CUSTOM LEG TRACK

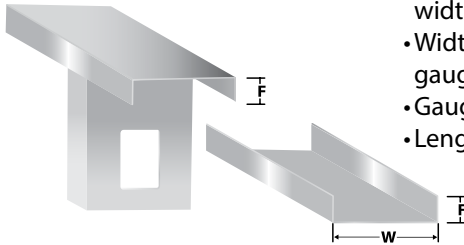

Product Data:

- Designation: CLT or VST width x gauge
- Widths: Multiple sizes and gauges available
- Gauge: Multiple sizes available
- Lengths: Standard 10'

Uses:

- CLT used for standard built construction with channel or bracing attached within 2' of track member to each stud
- For attachment at top of infill curtain wall systems to primary frame; allows for one half inch of live load deflection or settlement of the primary frame without transferring the load to the exterior wall while bracing the wall against lateral forces
- Variable width and height for track-in-track application such as panel construction

(WS) WEB STIFFENERS

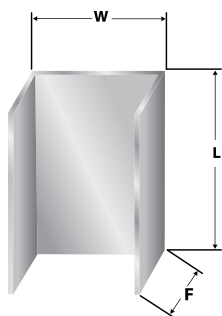

Product Data:

- Designation: WS W x F x gauge
- Length: 4, 6, 7-1/4, 8, 9-1/4, 10, 12 inch
- Galvanized finish
- For axial capacities contact Telling Industries Engineering

Uses:

- For web reinforcement of C shaped framing members
- Allow transfer of axial loads through joists at bearing conditions of platform frames

UTILITY ANGLE/ROLLED ANGLE (RA)

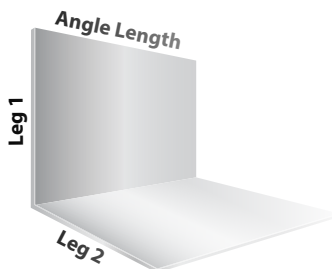

Product Data:

- Available in most sizes, lengths, and gauges
- 14ga standard right angle: 1.5" x 1.5" and 2.0" x 2.0"-16ga, 18ga standard right angle, 30mil, 20S 33mil: 1.5" x 1.5", 2.0" x 2.0", 3.0" x 3.0"
- 12ga, and any specialty angles > 3"x3" up to 8"x 8"

Uses:

- For miscellaneous attachments of intersection framing components
- For attachment of joist framing components to flush mounted headers
- For attachment of solid blocking sections to adjacent studs of joists
- For alternate screw attachment of CRC bridging to stud webs in lieu direct weld
- For 90 degree corner enclosures at lapped framing location; provides in-plane stability of framework

Note: 4 Screws min.

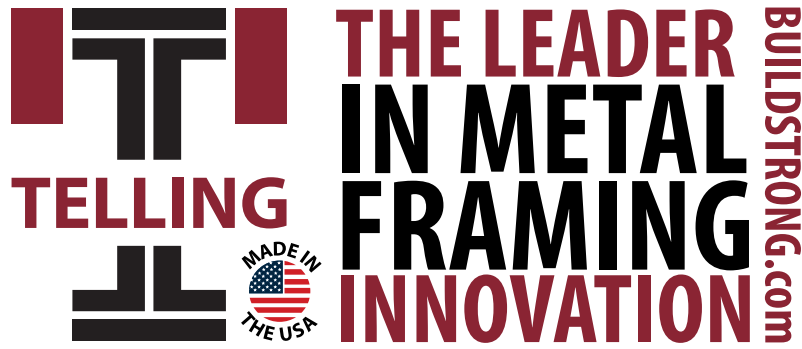

Technical information and CAD drawings available at
www.BuildStrong.com | **ARCAT**



- CORPORATE HEADQUARTERS:** 4420 Sherwin Road Willoughby, OH 44094
E-mail: sales.corp@tellingindustries.com | **Phone:** 440-974-3370 | **Toll Free:** 866- 372-6384 | **Fax:** 440-974-3408
- MIDWEST FACILITY:** 2105 Larrick Road Cambridge, OH 43725
E-mail: sales.corp@tellingindustries.com | **Phone:** 740-435-8900 | **Toll Free:** 866-357-8837 | **Fax:** 740-435-8915
- NORTHEAST FACILITY:** 1050 Kennedy Road Windsor, CT 06095
E-mail: sales.corp@tellingindustries.com | **Phone:** 860-731-7975 | **Toll Free:** 866- 372-6384 | **Fax:** 860-731-7976
- MIDSOUTH FACILITY:** 1400 Southwire Drive Osceola, AR 72370
E-mail: sales.corp@tellingindustries.com | **Phone:** 870-563-6065 | **Toll Free:** 888-711-3124
- SOUTHEAST FACILITY:** 1200 W Martin Luther King Blvd, Plant City, FL 33563
E-mail: sales.corp@tellingindustries.com | **Phone:** 440-974-3370 | **Toll Free:** 866- FRAME-TI (372-6384) | **Fax:** 440-974-3408

ENGINEERING AND DESIGN SERVICES (QUOTED) & TECHNICAL SERVICES (FREE)
technical@tellingindustries.com 1-866-372-6384
 440-478-8625 (direct)