

# THE LEADER IN METAL FRAMING INNOVATION

INNOVATIVE, RESPONSIVE SOLUTIONS FOR ALL YOUR METAL FRAMING NEEDS



## TELLING INDUSTRIES

[www.BuildStrong.com](http://www.BuildStrong.com) | 866-372-6384



# OVER 1,000,000+ UNIQUE PRODUCT SKU'S & 150+ UNIQUE ROLL FROM PROFILES

## Supreme EQ Stud & Track

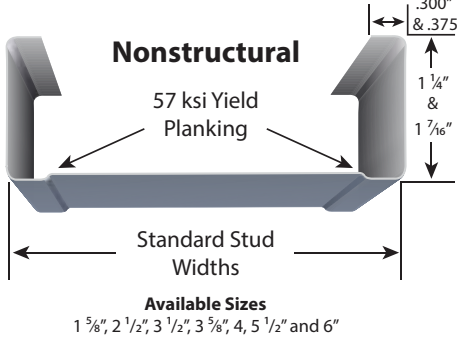

## Structural Studs

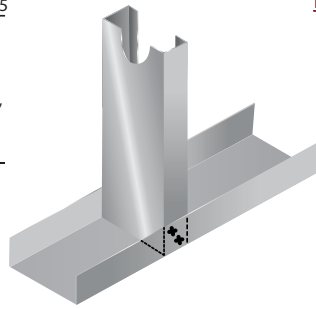

## Knee Wall Support Bracket Assembly



## (RC) Resilient Furring Channel

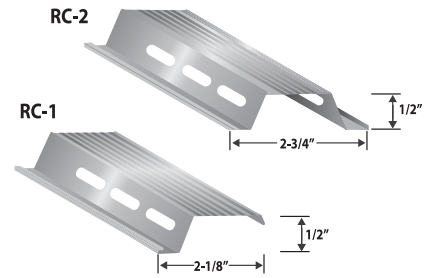

## (CA) Clip Angles | Utility Angle True-Bridge Clips

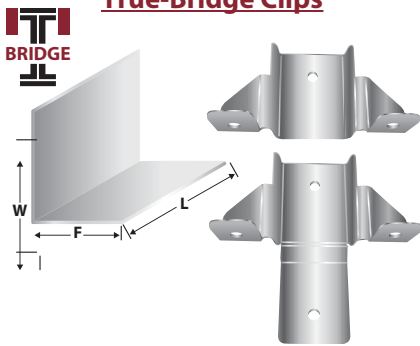

## (RA) Rolled Angles

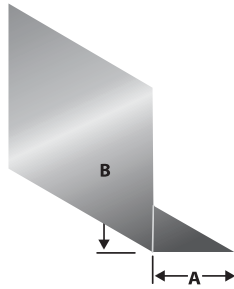

## T-Back Clip



## Titan Header



## T-Block

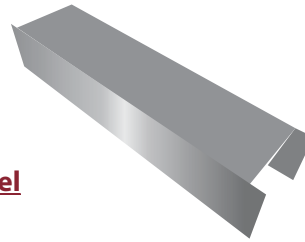

## (CRC) Cold-Rolled Channel

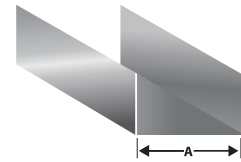

## (ZFC) Z-Furring Channel

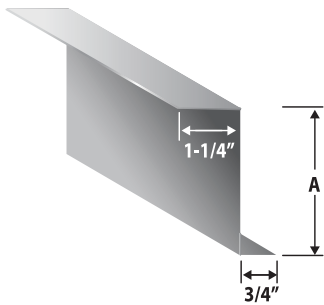

## (DWFC) Drywall Furring Channel Also Called Hat Channel

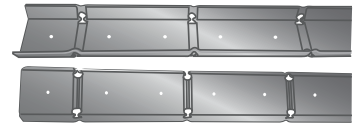
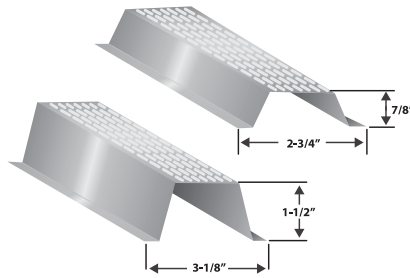

## (DCB) Corner Bead



## Area Separation Wall

### C-Track, Cap, Edge or End Closure

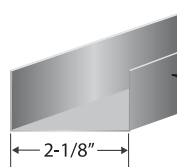

### H-Stud, 25-Gaug

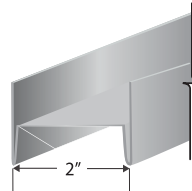

## Slotted Track

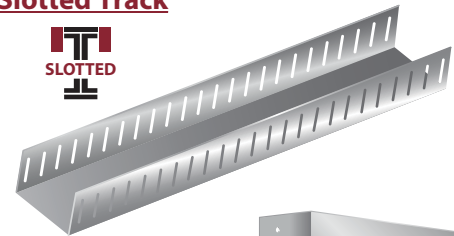

## TRC Rigid Clips

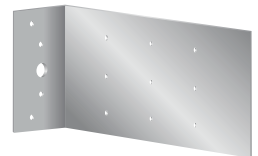

## Shaftwall Products

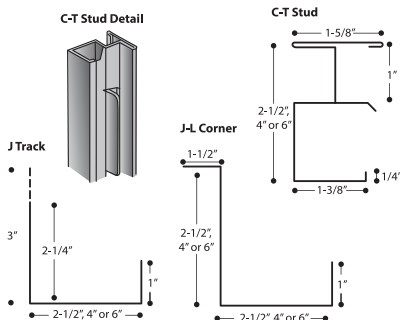

## (FS) Flat Strapping

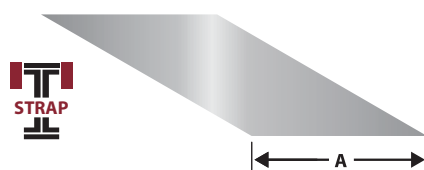

## VERSADRY DRYWALL TRACK



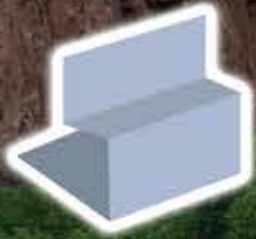

# VERSADRY DRYWALL TRACK

VersaDry protects walls from water damage with its 2" shelf that lifts drywall off the floor.

**KEEPS  
DRYWALL DRY**

**IMPROVES  
ACCOUSTICAL  
PERFORMANCE**

**ALLOWS STANDARD  
DRYWALL SIZES TO RISE  
2" ABOVE CEILINGS**

**HELPS REDUCE  
MOLD GROWTH**

**IMPROVES FIRE  
RESISTANCE**

**DESIGN YOUR BUILDING  
TO PERFORM!**



**NO  
CAULK NEEDED  
SAVES \$\$\$**



HOSPITALS



SCHOOLS



APARTMENTS



KITCHENS



POTENTIAL WET ENVIRONMENTS



HOSPITALITY



**INNOVATION, SERVICE, QUALITY**

[www.BuildStrong.com](http://www.BuildStrong.com) • 1-866-372-6384



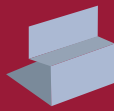

**VERSADRY**  
DRYWALL TRACK



**NON STRUCTURAL**

**VERSADRY TRACK PROTECTS DRYWALL FROM WATER DAMAGE**

**VERSADRY DRYWALL TRACK SYSTEM**

Patented system allows the installation of drywall to sit 2 inches off the floor on a steel shelf. This shelf mitigates the wicking of water both during construction and the life of the building.

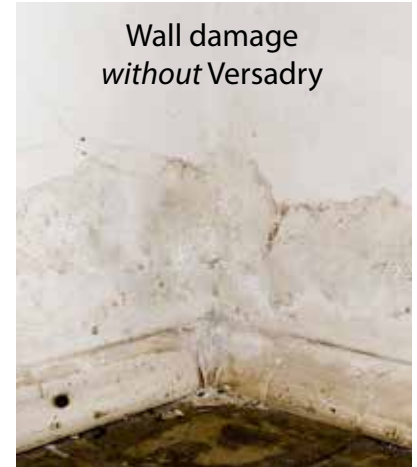
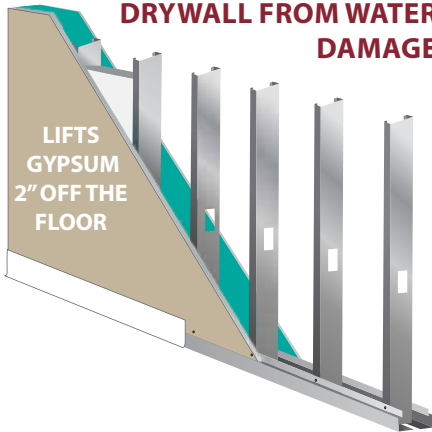

**VERSADRY TRACK: 2 PIECE DESIGN (Ideal for retrofits)**

Thickness Nomenclature	Non-Rate Length	1 Hour Rated	2 Hour Rated	Min Base Metal Thickness (in)	Design Thickness (in)	Min Yield Strength (ksi)	Standard Galvanization	Web Sizes (in)
VDT2-18	24'	10'	10'	0.0179"	0.0186"	33 ksi	G40	2 piece design. Any web size is possible
VDT2-30	12'	N/A	N/A	0.0296"	0.0312"			

**VERSADRY TRACK: 1 PIECE DESIGN (Ideal for new construction)**

Thickness Nomenclature	Non-Rate Length	1 Hour Rated + Clip	2 Hour Rated + Clip	Min Base Metal Thickness (in)	Design Thickness (in)	Min Yield Strength (ksi)	Standard Galvanization	Web Sizes (in)
VDT1-18	Max 24'	Max 24' Length (10' Recommended)		0.0179"	0.0186"	33 ksi	G40	3-5/8", 4", 5.5", 6"
VDT1-30				0.0296"	0.0312"			

**VERSADRY DIMENSIONS**

	Gypsum Ledge Height	Gypsum Ledge Width
Non-Rated	2.00"	0.688"
1 Hour Fire Rated	2.00"	0.688"
2 Hour Fire Rated	2.00"	1.295"

- KEEPS GYPSUM DRY
- IMPROVED FIRE RESISTANCE WITHOUT CAULK
- IMPROVED ACOUSTICAL PERFORMANCE
- PROTECTS WALLS FROM BASEBOARD DAMAGE
- HELPS REDUCE MOLD GROWTH
- ALLOWS

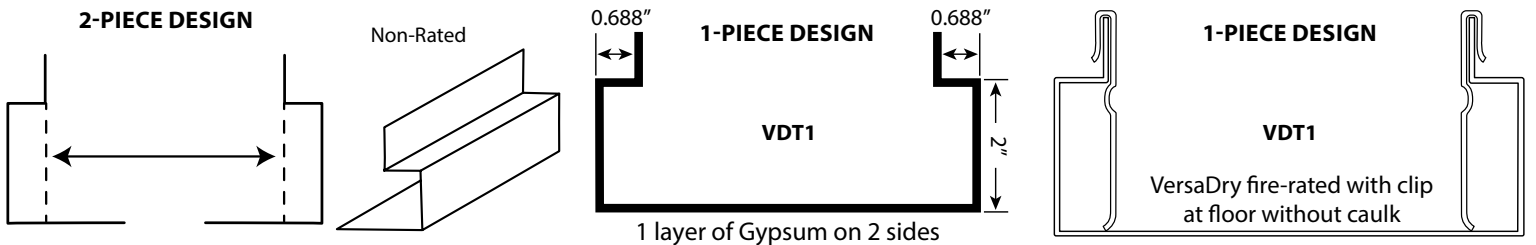

**VERSADRY TRACK CERTIFICATIONS:**

**FIRE RESISTANCE:** 3rd party tested to meet a 1 hour & 2 hour Fire Rating for UL Wall Design U423 per ASTM E119



- 1 hour Fire Rating for UL Wall Design U423 per ASTM E119 with 18mil VersaDry Track, 1 layer of 5/8" Type X Gypsum, & 20ga 3-5/8" studs spaced 16" OC.
- 2 hour Fire Rating for UL Wall Design U423 per ASTM E119 with 18mil VersaDry Track, 2 layers of 5/8" Type X Gypsum, & 20ga 3-5/8" studs spaced 16" OC.
- VersaDry 1 piece design with clip at floor & ceiling passed ASTM E119 1-hour and 2-hour fire and hose stream test without caulk at Intertek certified independent 3rd party test lab.

**ACOUSTICAL PERFORMANCE:** 3rd part tested per ASTM E90-09 and calculated per ASTM E413-16.

- STC = 45 for Non-Fire Rated 18mil VersaDry Track w/ 1 layer of 5/8" Type X Gypsum
- STC = 48 for Non-Fire Rated 18mil VersaDry Track w/ 1 layer of Impact Resistant Gypsum
- STC = 46 for 1 hour Fire Rated 18mil VersaDry Track w/ 1 layer of Impact Resistant Gypsum
- STC = 53 for 2 hour Fire Rated 18mil VersaDry Track w/ 2 layers of 5/8" Type X Gypsum



**INNOVATION, SERVICE, QUALITY**

www.BuildStrong.com • 1-866-372-6384





# KNEE WALL SUPPORT BRACKET ASSEMBLY



Patent Pending

**Knee Wall Support Bracket Assembly:** What is it? An engineered system comprised of a 1/2" steel base plate welded to a 14ga structural stud.

In the construction industry, a "knee wall" is a term used to describe a short wall that is typically half the height of a full-sized wall. Also known as a "pony wall" or "cripple wall," knee walls are used for various purposes in building design, including providing structural support, dividing spaces, and enhancing aesthetic appeal.

## TELLING'S KNEE WALL STUD & BASE PLATE:

- Knee Wall Stud & Base Plate are loaded perpendicular to the leg
- Knee Wall Stud is 300S162-68 14 ga. Competing products utilize 12ga material
- Base Plate is 8" x 3-3/8" and 1/2" thick with groove for Stud
- 1 Knee Wall Stud per Support Stud & Base Plate. Competitive products utilize 2 studs per support bracket
- Higher Allowable Loads than competing products

Knee Wall Assembly

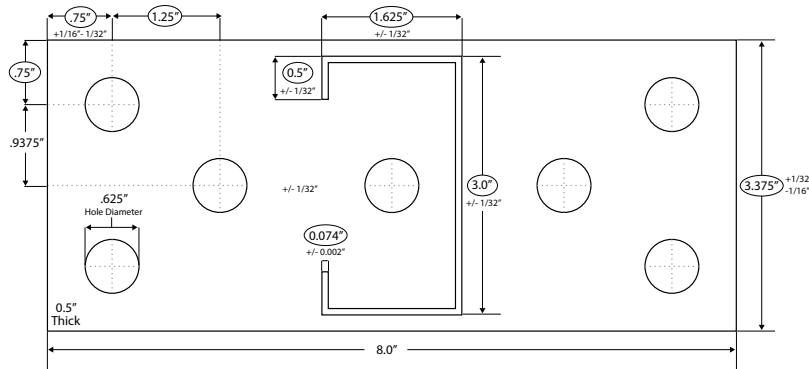
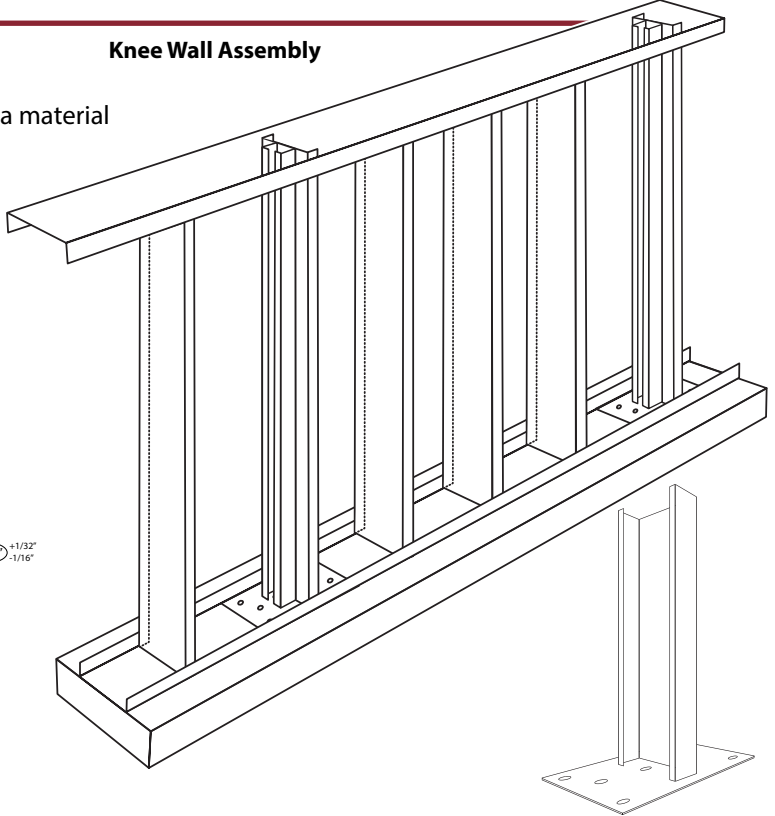

Base plate thickness = 1/2" (36ksi)  
 Bolt size = 1/2" Hole size = 5/8"  
 Knee wall stud = 300S162-68

Allowable Bending Capacity (kip-in)				<b>Knee Wall Support Stud:</b> 300S162-68 (50 ksi) <b>Anchor quantity:</b> 4 at each corner <b>Anchor Type:</b> Hilti Kwik-TZ2 <b>Anchor Size:</b> 1/2 inch <b>Concrete Thickness:</b> 5.5 inches <b>Concrete Strength (cracked)</b> 3000 psi <b>Embedment:</b> $l_{eff}$	Anchor Layout			
Height (in)	Pony Wall Section	Stud to Baseplate Weld	Anchor to concrete		[Anchor Diagram]			
24	14.04	12.66	12.57		[Anchor Diagram]			
36	13.69	12.66	12.57		[Anchor Diagram]			
48	12.50	12.66	12.57	[Anchor Diagram]				

Allowable Point Load Applied at the Top (lbf)								
Height (in)	Strength Limit State	Combined Strength and Deflection						
		L/90	L/120	L/180	L/240	L/360	L/480	L/600
24	524	524	524	524	524	524	430	344
36	349	349	349	349	349	255	191	153
48	260	260	260	260	215	143	108	86

Allowable Distributed Load Applied along the Wall (plf)								
Height (in)	Strength Limit State	Combined Strength and Deflection						
		L/90	L/120	L/180	L/240	L/360	L/480	L/600
24	524	524	524	524	524	524	524	459
36	233	233	233	233	233	227	170	136
48	130	130	130	130	130	96	72	57

Representative loads based on specific quantity, type of anchors and concrete thickness. For additional anchor type and concrete thickness refer to detailed knee-wall technical catalog.



## INNOVATION, SERVICE, QUALITY

www.BuildStrong.com • 1-866-372-6384





# TRC - TELLING RIGID CLIPS



CLIPS

Telling Industries manufactures an extensive line of Metal Framing Connectors and Clips. Standard gauges and sizes are complimented with specialized and custom fabricated Clips to meet all your Metal Framing needs and available in standard G60 and optional G90 coatings. All Telling products, including Metal Framing Connectors, are proudly made in the USA.

## TRC A Series Rigid Right Angle Clips

Predominately Used to Attach Metal Framing to Metal Framing

Section	Clip Thickness	Leg Length (in)	Clip Length (in)	BKT Quantity
TRC223	0.0538" (16ga)	2" x 2"	3.0"	150
	0.0677" (14ga)			
	0.0966" (12ga)			
TRC225	0.0538" (16ga)	2" x 2"	5.0"	120
	0.0677" (14ga)			
	0.0966" (12ga)			
TRC227	0.0538" (16ga)	2" x 2"	7.0"	100
	0.0677" (14ga)			
	0.0966" (12ga)			
TRC229	0.0538" (16ga)	2" x 2"	9.0"	75
	0.0677" (14ga)			
	0.0966" (12ga)			
TRC2211	0.0538" (16ga)	2" x 2"	11.0"	30
	0.0677" (14ga)			
	0.0966" (12ga)			

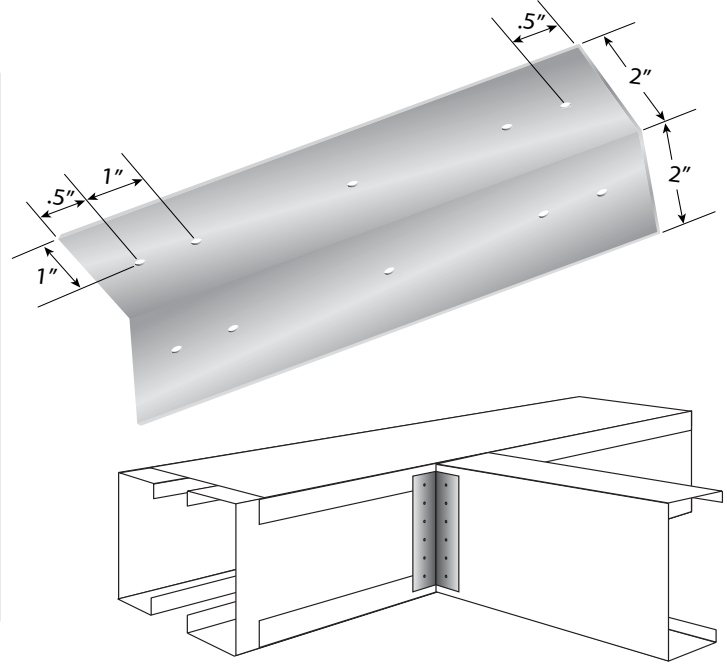

Clip allowable load data is available and 3rd party PE validated.

## TRC B Series Rigid Right Angle Clips

predominately used to attach Metal Framing to Metal Framing

Section	Clip Thickness	Leg Length (in)	Clip Length (in)	BKT Quantity
TRC133	0.0538" (16ga)	1.5" x 3"	3.0"	150
	0.0677" (14ga)			
	0.0966" (12ga)			
TRC143	0.0538" (16ga)	1.5" x 4"	3.5"	120
	0.0677" (14ga)			
	0.0966" (12ga)			
TRC145	0.0538" (16ga)	1.5" x 4"	5.5"	100
	0.0677" (14ga)			
	0.0966" (12ga)			
TRC147	0.0538" (16ga)	1.5" x 4"	7.5"	100
	0.0677" (14ga)			
	0.0966" (12ga)			
TRC149	0.0538" (16ga)	1.5" x 4"	9.5"	75
	0.0677" (14ga)			
	0.0966" (12ga)			
TRC1411	0.0538" (16ga)	1.5" x 4"	11.5"	30
	0.0677" (14ga)			
	0.0966" (12ga)			
TRC156	0.0538" (16ga)	1.5" x 5"	6.0"	50
	0.0677" (14ga)			
	0.0966" (12ga)			
TRC173	0.0538" (16ga)	1.5" x 7"	3.0"	50
	0.0677" (14ga)			
	0.0966" (12ga)			

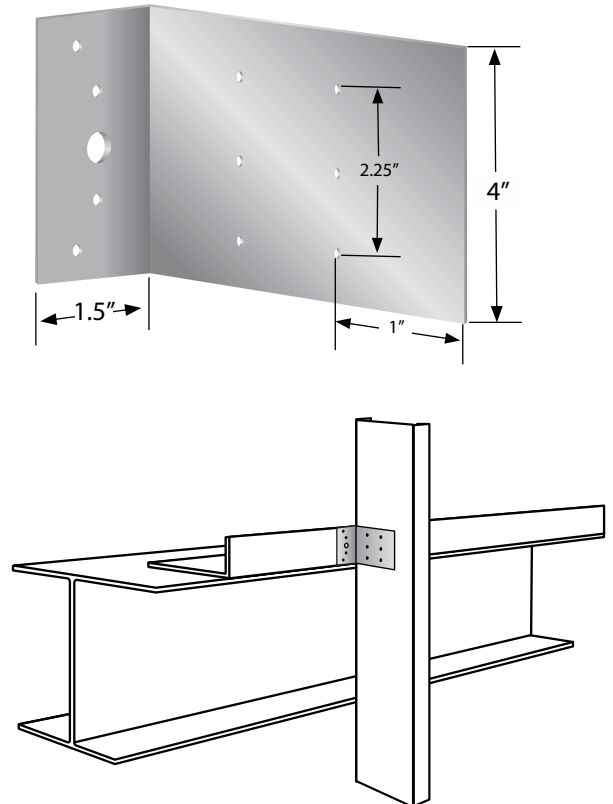

\*All Sales are subject to Telling's Terms & Conditions found at [www.buildstrong.com](http://www.buildstrong.com). Prices are subject to change without further notice. Please contact your Telling Sales Representative for further inquiries.

\*\*Prices Listed are for each G60 clip when sold in BUCKET quantities. Individual (EA) cost on the clips will be +5% from the bucket price.



# INNOVATION, SERVICE, QUALITY

[www.BuildStrong.com](http://www.BuildStrong.com) • 1-866-372-6384



# TELLING, THE CUSTOM CLIP EXPERT!

## NEED SOMETHING SPECIAL? WE CAN DO IT!



### We can drill and bend any darn thing!

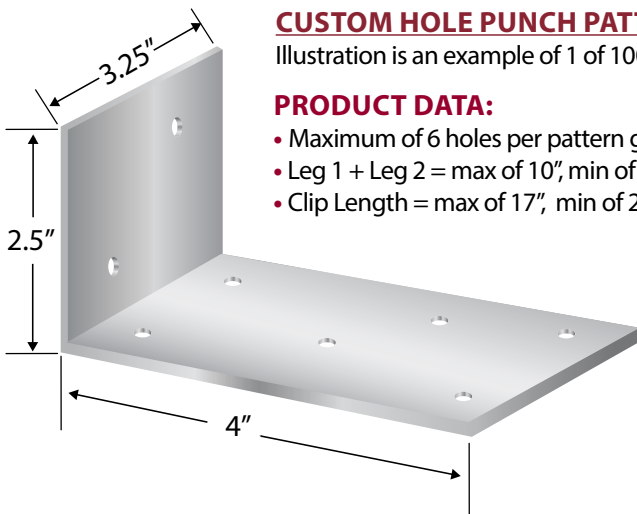

#### CUSTOM HOLE PUNCH PATTERNS

Illustration is an example of 1 of 1000's of possible custom hole patterns.

#### **PRODUCT DATA:**

- Maximum of 6 holes per pattern grouping
- Leg 1 + Leg 2 = max of 10", min of 1.5"
- Clip Length = max of 17", min of 2.0"

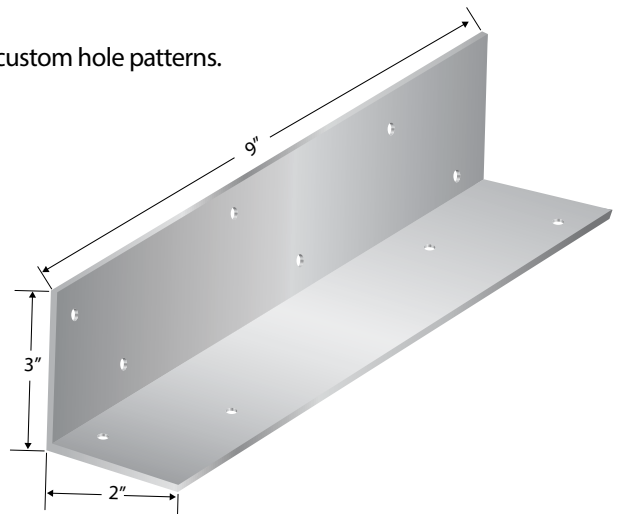

If your project needs connectors not shown in this catalog, please contact your inside sales rep or send an inquiry to [www.buildstrong.com](http://www.buildstrong.com).



## INNOVATION, SERVICE, QUALITY

[www.BuildStrong.com](http://www.BuildStrong.com) • 1-866-372-6384



### T-BACKING CLIP (TBKC) WALL SUPPORT CLIPS

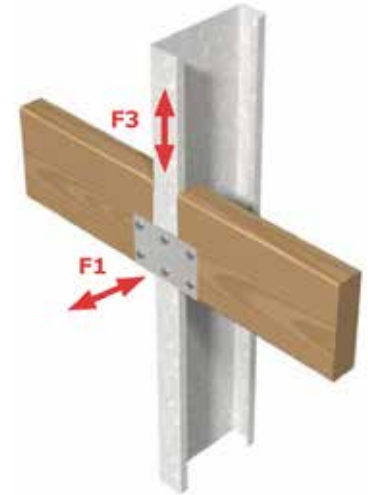
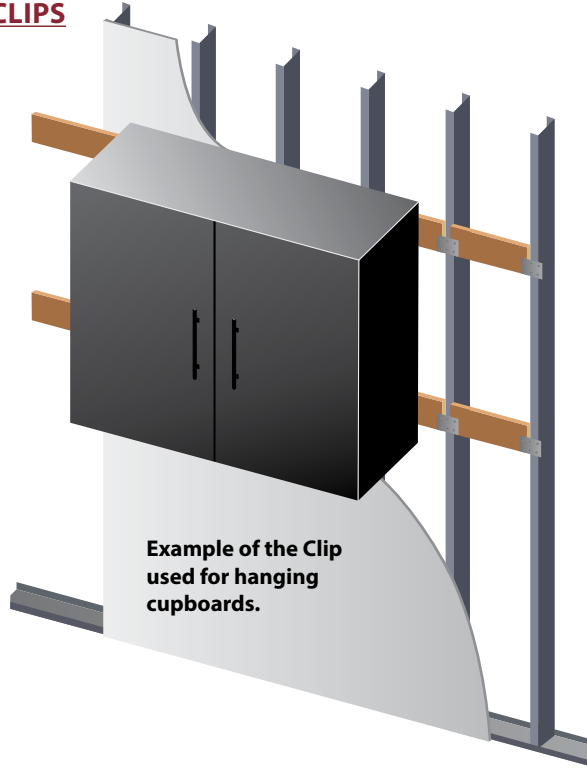
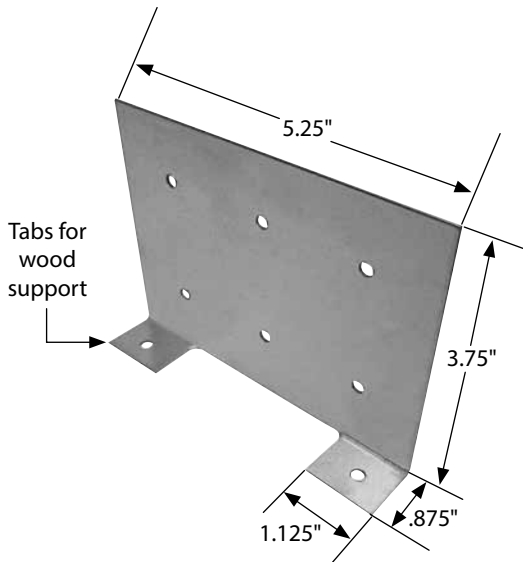

### ALLOWABLE LOADS

Part Number	Stud Properties			F1 Allowable Loads (Lbs)		F3 Allowable Loads (lbs)	
	Mil	Gauge	Fy (ksi)	2 #8 Screws	3 #8 Screws	2 #8 Screws	3 #8 Screws
TBKC	33	20 (S)	33	142	213	321	483

#### Notes:

1. The allowable loads are based on the steel properties of the members being connected, per AISI S100.
2. Allowable loads indicated on the table(s) are for force in single direction only. The designer shall use the combined forces check as required by AISI S100 if more than one force is applied to the connection.
3. The nominal strength of the screw must be at least 3.75 times the allowable loads.
4. Values include a 3.0 factor of safety.
5. Penetration of screws through joined materials should not be less than three exposed threads. Install and tighten screws in accordance with the screw manufacturer's recommendations.
6. Allowable loads have not been increased for wind, seismic activity, or other factors.



### CUSTOM PRESS BRAKE PARTS:

Telling welcomes challenging part geometries! We are happy to work with all designs and concepts to produce smaller volume customization on our unique and flexible equipment, including:

- Custom Track with the Legs longer than the web such as 3-5/8" web with 6" legs
- Custom Right Angle legs & lengths up to 12'
- Custom Brackets with lengths up to 12'





T-Bridge Clips are a highly engineered new product from Telling used with T-Brace **or traditional CRC mechanical bridging**.

Telling's T-Bridge clips were engineered with the installer in mind. The ergonomic design facilitates easy screw drive access and hands free assembly. The patented T-Bridge Clips are made of 18 gauge, premium steel and are available in two functional designs, terminating and joining.

## TYPES OF T-BRIDGE CLIPS:

### T-BRIDGE CLIP (TERMINATING)

- Used to join T-Brace to a Stud at a corner, doorway, or end of wall
- 1.75" X 3.2" X 1.25"

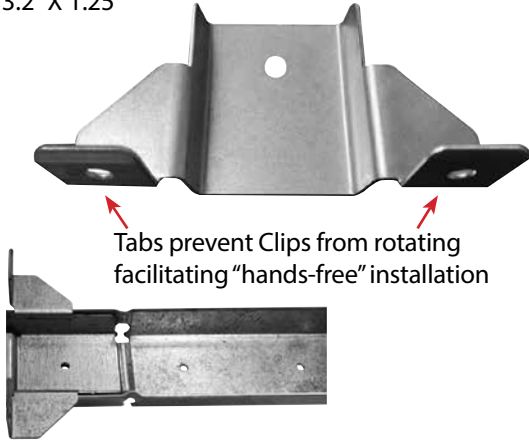

### T-BRIDGE CLIP (JOINING)

- Used to joint T-Brace to T-Brace or CRC to CRC for higher load applications
- 3.5" X 3.2" X 1.25"

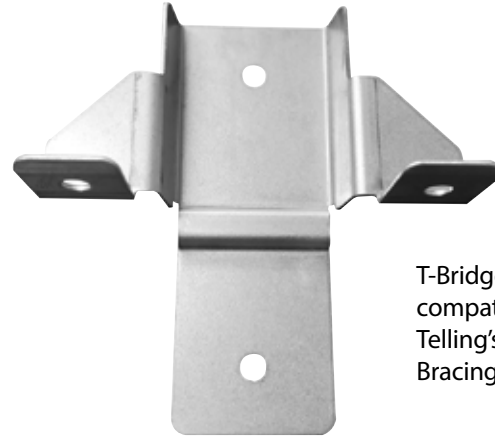

T-Bridge clips are compatible with Telling's Standard CRC Bracing & T-Brace.

SEE THE VIDEO



### FEATURES:

- Made of Galvanized Steel
- Highly Engineered for Ease of Installation
- Slides Easily into Place When Used in Conjunction with T-Brace

### BENEFITS:

- Reduces Installation Time
- 10% Savings on Material and Labor Costs
- No Clips or Welding Required
- Easy Installation Due to Patented Design

SECTION	QUANTITY
<b>TBCJ150-43</b>	200pcs/bkt
<b>TBCT150-43</b>	200pcs/bkt

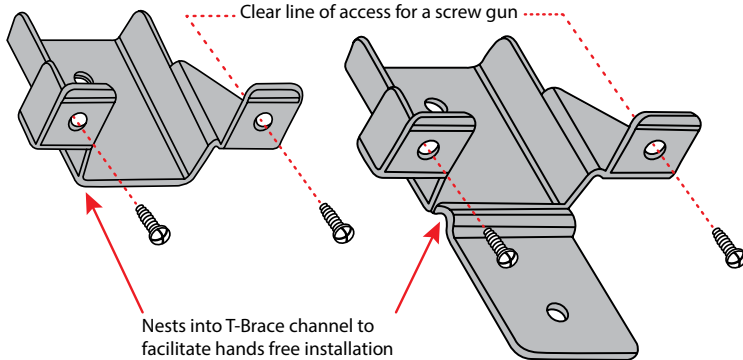

### USES:

- Used to join T-Brace to a stud at a corner, doorway, or end of wall
- 1 Screw to T-Brace and up to 2 Screws to Stud
- Clip is also compatible with standard CRC Bracing



#### Allowable Rotational Loads

CFS Member	Tested Ultimate Moment (in-lbs)	Allowable Load (in-lbs)	Stiffness (in-lbs/radian)
<b>362S162-68</b>	1168	546	4932
<b>362S162-97</b>	1648	770	6972
<b>600S162-68</b>	1261	589	4026
<b>600S162-97</b>	2011	939	7097

#### Allowable Lateral Loads

CFS Member	Tested Ultimate Load (lbs)	Allowable Load (in-lbs)	Stiffness (lbs/in) at 0.5 Pult
<b>362S162-68</b>	1268	592	1260
<b>362S162-97</b>	1535	717	1998
<b>600S162-68</b>	1312	613	1390
<b>600S162-97</b>	2299	1074	4575

#### Table Notes:

1. Tested results are the average loads utilizing 16ga T-Brace Bridging with 18ga T-Bridge Clips.
2. The Rotational Stiffness is calculated based on the average test deflection divided by the load.
3. The Lateral Stiffness is calculated based on the average test deflection divided by the load at 50% of the ultimate load.
4. Results are 3rd party PE certified

Blocking a metal stud wall refers to installing a short piece of stud horizontally between the vertical studs. The purpose of blocking is to provide an attachment support point for mounted construction features like shelving, frames, cabinets, railings or other fixed hardware.

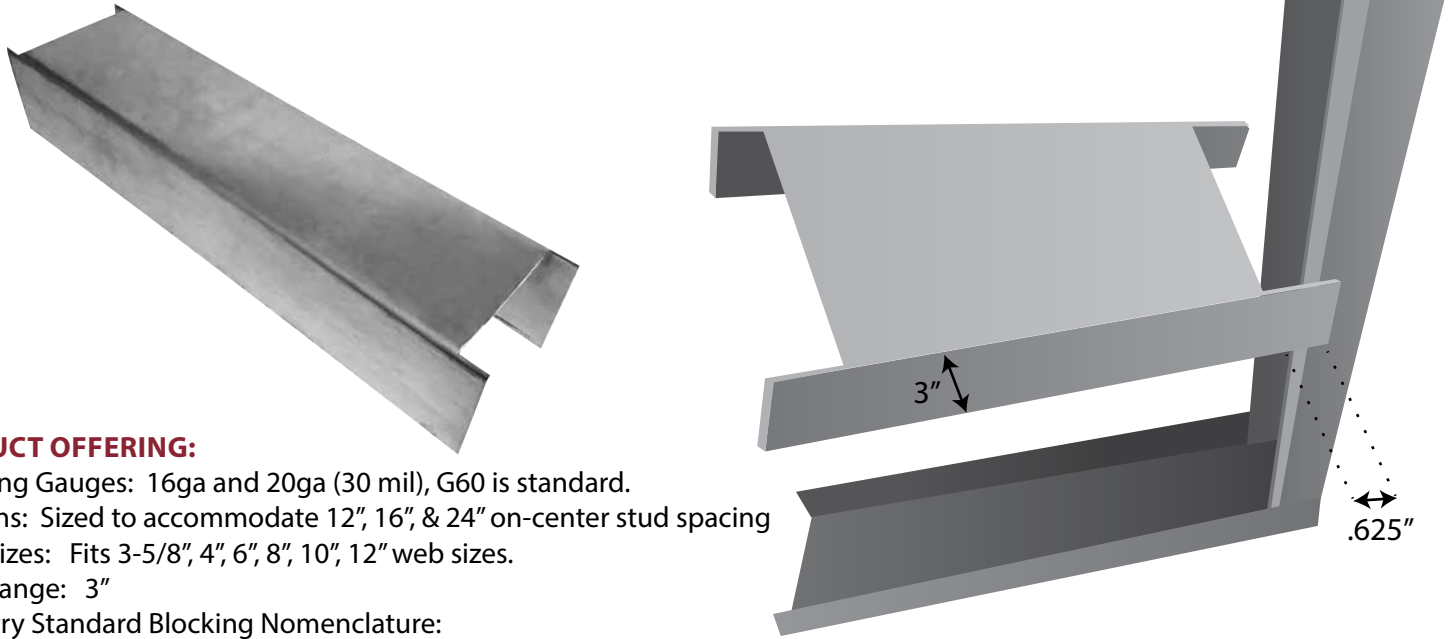

**PRODUCT OFFERING:**

- Blocking Gauges: 16ga and 20ga (30 mil), G60 is standard.
- Lengths: Sized to accommodate 12", 16", & 24" on-center stud spacing
- Web Sizes: Fits 3-5/8", 4", 6", 8", 10", 12" web sizes.
- Leg/Flange: 3"
- Industry Standard Blocking Nomenclature:  
TB362-300-S16-54, which is Track Blocking, 3-5/8" web, 3" flange, Stud spacing of 16" on center, 54 mils thick

T-Block Part No.	Gauge	Minimum Thickness (in)	Design Thickness (in)	Tensile Strength (KSI)	Coating	Web (in)	Flange (in)	Stud Spacing (O.C.)	Standard Packaging
TBLK362-300-S12-30	20	0.0296	0.0312	33	G40	3-5/8"	3"	12"	10pc Bundles
TBLK362-300-S16-30	20	0.0296	0.0312	33	G40	3-5/8"	3"	16"	
TBLK362-300-S24-30	20	0.0296	0.0312	33	G40	3-5/8"	3"	24"	
TBLK362-300-S12-54	16	0.0538	0.0566	50	G60	3-5/8"	3"	12"	
TBLK362-300-S16-54	16	0.0538	0.0566	50	G60	3-5/8"	3"	16"	
TBLK362-300-S24-54	16	0.0538	0.0566	50	G60	3-5/8"	3"	24"	
TBLK600-300-S12-30	20	0.0296	0.0312	33	G40	6"	3"	12"	
TBLK600-300-S16-30	20	0.0296	0.0312	33	G40	6"	3"	16"	
TBLK600-300-S24-30	20	0.0296	0.0312	33	G40	6"	3"	24"	
TBLK600-300-S12-54	16	0.0538	0.0566	50	G60	6"	3"	12"	
TBLK600-300-S16-54	16	0.0538	0.0566	50	G60	6"	3"	16"	
TBLK600-300-S24-54	16	0.0538	0.0566	50	G60	6"	3"	24"	

T-Block Item No.	Minimum Thickness (in)	Design Thickness (in)	Tensile Strength (KSI)	Web (in)	Flange (in)	Max Stud Spacing (O.C.)	Stud & Track	Allowable Load (lbf)
TBLK362-300-30	0.0296	0.0312	33	3-5/8"	3"	16"	20 ga (30 mil) Fy=33 ksi	Horizontal: 249 lbf Vertical: 339 lbs
TBLK362-300-54	0.0538	0.0566	50	3-5/8"	3"	16"	12 ga (97 mil) Fy=50 ksi	Horizontal: 647 lbf Vertical: 692 lbs
							16 ga (54 mil) Fy=50 ksi	Horizontal: 648 lbf Vertical: 926 lbs
							20 ga (30 mil) Fy=33 ksi	Horizontal: 288 lbf Vertical: 396 lbs

Blocking is connected to studs with (1) #10-16 screw at each flange.

Allowable Loads were determined based on the test results and 3rd party PE reliability analysis per AISI S100-16 Chapter K.



# T-BRACE BRIDGING



## INTRODUCING TRUE-BRACE, A NEW PRODUCT INNOVATION FROM TELLING INDUSTRIES

T-Brace is used as mechanical bridging for studs. Typically, U-Channel or CRC, is attached to studs via clips or a weld to eliminate stud rotation and bending under wind or axial loads. 1-1/2" True-Brace is passed through the stud knockout and snapped securely into place with Telling's patented technology saving valuable time and money.

T-Brace features an innovative, highly engineered design that securely locks the T-Brace into the stud slot hole without the need for clips or welding for most non-structural applications.

Patent 10,309,107 | 10,590,647

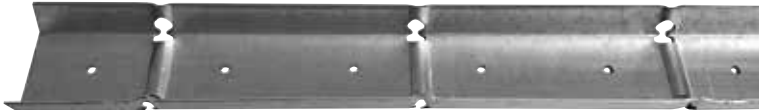

### FEATURES:

- Made of Galvanized Steel
- Highly Engineered for Secure Fit in Stud Knockout
- T-Brace Locks into the Stud without Clips or Welding
- Notches every 4" to accommodate 12", 16", 24" OC Stud Spacing

### BENEFITS:

- Reduces Installation Time
- 10% Savings on Material and Labor Costs
- No Clips or Welding Required
- Easy Installation due to patented design

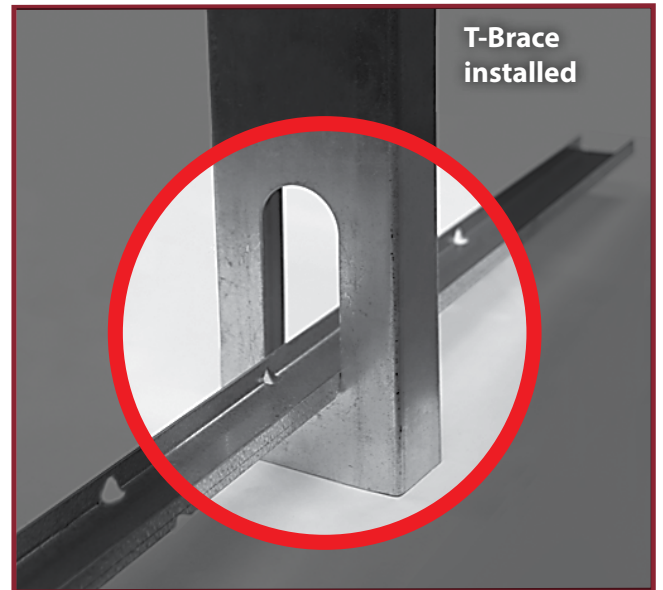

SEE THE VIDEO



T-Brace with self nesting geometry to fit one part inside of another and secured with a screw. T-Brace locking features spaced every 4" to accommodate 12", 16" and 24" on center stud spacing.

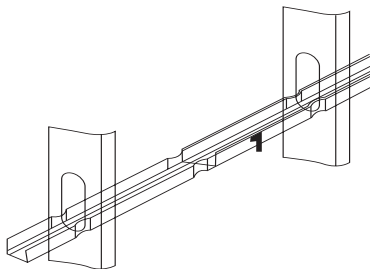

Note: T-Brace is designed to lock in to studs with oval punch-outs without clips. T-Brace requires a clip to work with rectangular punch-out studs.



# INNOVATION, SERVICE, QUALITY

[www.BuildStrong.com](http://www.BuildStrong.com) • 1-866-372-6384





# CORNER BEAD



**T-BEAD** Corner Bead is a new and improved, highly durable, galvanized bead. It provides a high-quality finish and solid protection at drywall corners. This traditional drywall finishing product can be nailed, stapled, screwed or clinched into place. Deep, knurled and perforated flanges are ideal for joint compound adhesion.

- Offers superior corrosion protection
- Strong metal reinforcement for drywall corners
- Engineered nose resists impact and forms a screed for finishing
- Ideal for humid, moisture-prone conditions and high-traffic areas

### FEATURES:

- Made of galvanized steel
- Optimized bend angle
- Reinforces drywall corners
- Prevents dents, scrapes and damage
- Deeper knurling for superior adhesion
- Staggered hole pattern for a smoother finish
- Engineered nose provides a straight, clean corner definition and guards against impact damage
- T-Bead's galvanized version meets ASTM C1047
- Joint cement adheres easily to knurled flanges and keys into perforations
- Creates a smooth, seamless surface along drywall corners and intersections
- New nose design requires less mud for a superior finish every time

### USES:

- Provides durable protection for drywall external corners

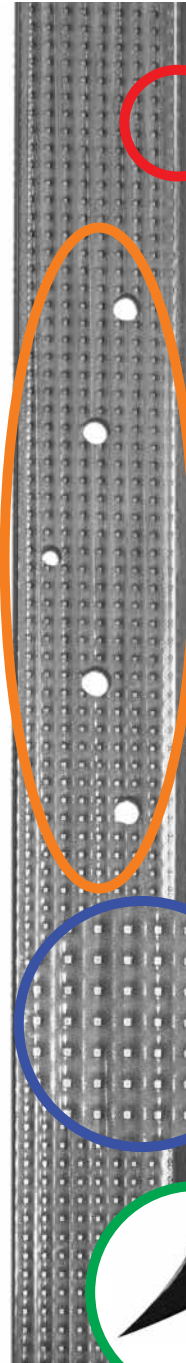

**New nose design requires less mud for a superior finish every time!**

**Revised hole pattern for a smoother finish**

**Deeper knurling for superior adhesion**

**Optimized bend angle**

Length	Pieces Per Carton	Cartons Per Pallet	Pieces Per Pallet	Lineal Feet Per Carton
8'	63	50	3150	503
9'	56	50	2800	503
10'	50	50	2500	500
12'	50	50	2500	600



## INNOVATION, SERVICE, QUALITY

[www.BuildStrong.com](http://www.BuildStrong.com) • 1-866-372-6384





# FLAT STRAP



### PRODUCT DATA:

- Designation: FS(Width)-Mil  
- Ex: FS200-30
- Stock widths: 2", 4", 6", 8" and 10"
- Custom Widths are available in increments of even inches
- Length: 10', 12', 14', 16', 18', 20', 22', & 24' (custom lengths available in 1' increments)  
- Note: 16' through 24' length will have additional packaging costs  
- 10 piece minimum order quantities must be strictly followed for 16' & longer lengths in order to package, ship, and handle safely

### GAUGES:

- 33KSI: 25, 22, 20, 20S & 18 gauge
- 50KSI: 20S, 22, 16, 14 & 12 gauge
- Cut off angle: 90°, 45°, 40°, 35°, 30°, 25°, 20°, 15°, 10°, 5°
- Available in smooth (2"-10") and knurled textures from (2" - 8").  
The knurled finish helps start a screw

### COATING:

- Drywall: Standard G-40 Hot Dipped Galvanized. Also Available in G-60 and G-90
- Structural: G-60 Hot Dipped Galvanized. Also Available in G-60 and G-90
- Meets applicable ASTM's for Structural and Drywall applications:  
- ASTM- A1003, A-653, A924, C-645, C754, C955, C1007

- Factory pre-cut angled ends in 5° increments
- Embossed knurled pattern to make it easier to start a screw
- Longer lengths available

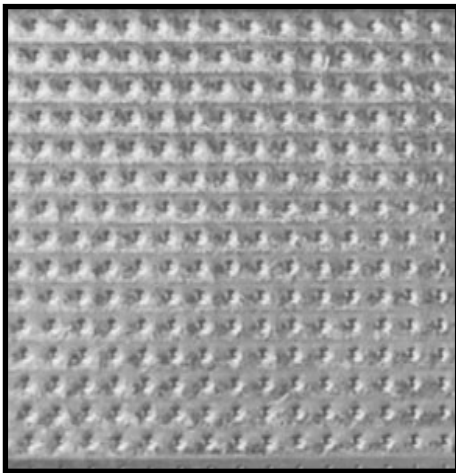
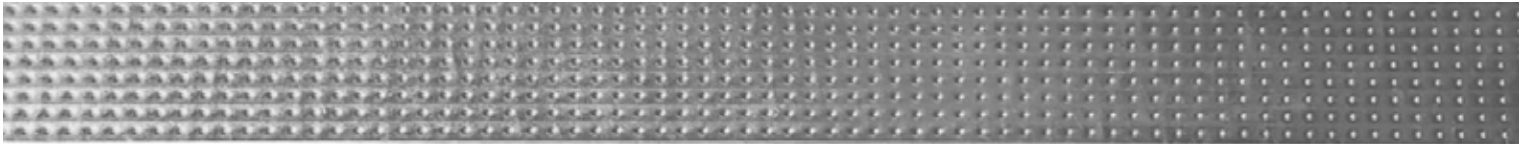

Knurled pattern for better screw starting.

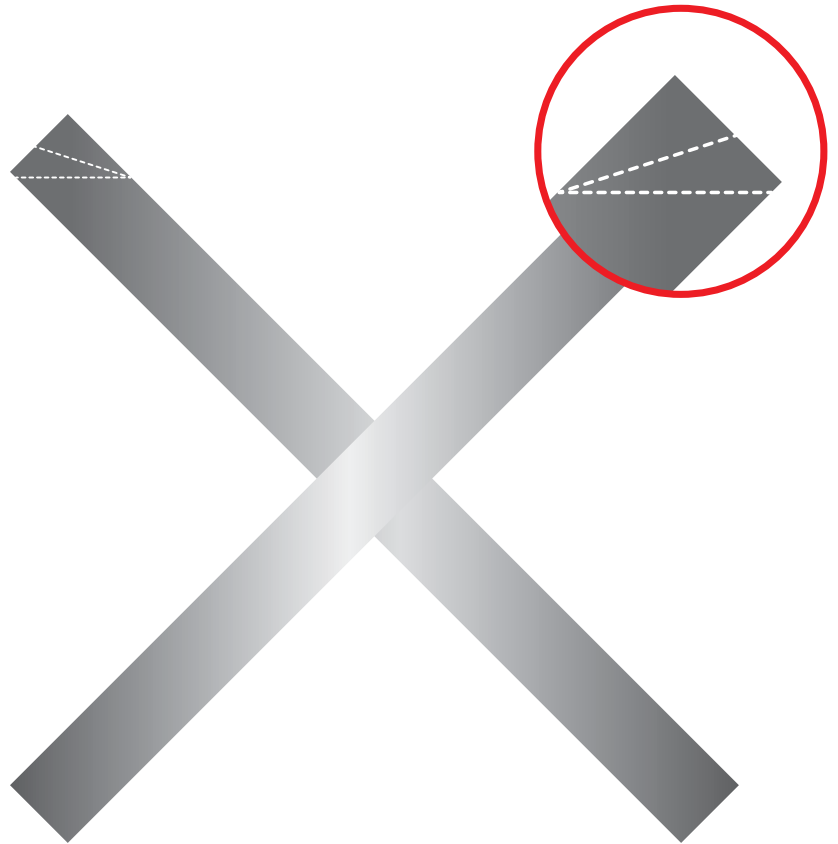

## INNOVATION, SERVICE, QUALITY

[www.BuildStrong.com](http://www.BuildStrong.com) • 1-866-372-6384





# SLOTTED TRACK



## WHAT IS TRUE-ACTION™ SLOTTED TRACK - HEAD OF WALL DEFLECTION SYSTEM?

True-Action™ Slotted Track is the industry preferred system for achieving head-of-wall deflection and fire resistance for interior and exterior walls. It meets movement and cycling requirements for ANSI/UL 2079 and is UL Classified for 1, 2, 3, and 4 hour fire-resistant ratings in head-of-wall fire-rated joint systems.

### BENEFITS:

- Fire-rated deflection system
- UL Classified in over 80 approved fire-rated systems
- Standard Slotted Track allows vertical movement
- Custom web, leg and lengths are available (Custom slot sizes are not available)
- Positive attachment provided for wall strength
- Absorbs head-of-wall and floor extension or compression movement
- Integrated with traditional wall systems
- Easy installation reduces labor costs



Telling Slotted Track is listed in many gypsum based UL Wall Designs utilizing 0.030" material or thicker for Studs with a web ranging from 2.5" to 8.0".



### 2.5" SLOTTED TRACK

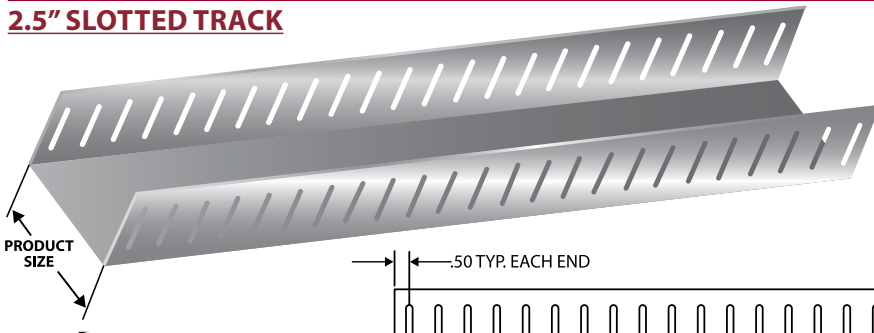

**30 EQD SLOTTED TRACK**  
Another Innovation  
From Telling Industries!

#### PRODUCT SIZES:

MAX WEB: 8"  
FLANGE: 2.5"

#### MATERIAL GAUGES:

.0235" MINIMUM  
.071" MAXIMUM

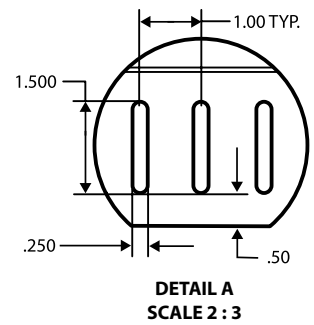
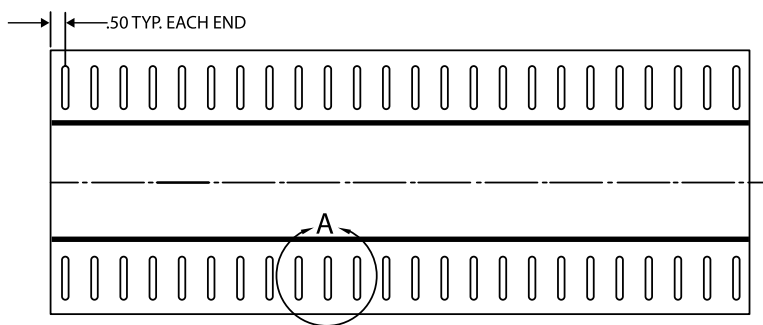

### 3" SLOTTED TRACK

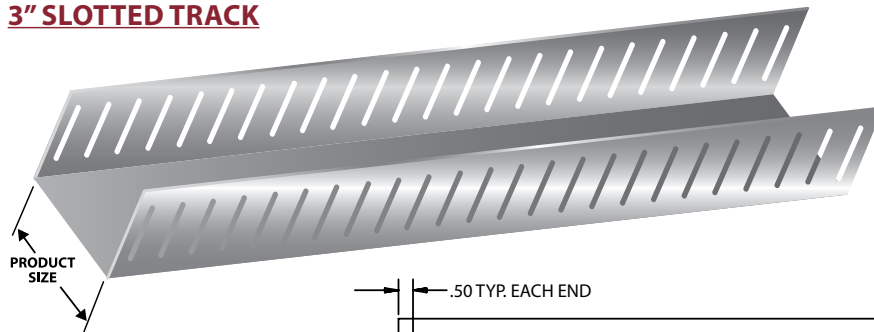

#### PRODUCT SIZES:

MAX WEB: 8"  
FLANGE: 3"

#### MATERIAL GAUGES:

.030" MINIMUM  
.054" MAXIMUM

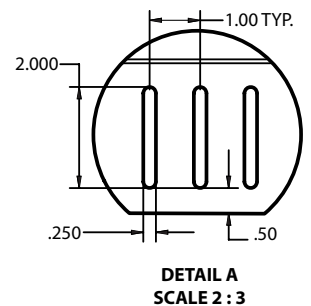
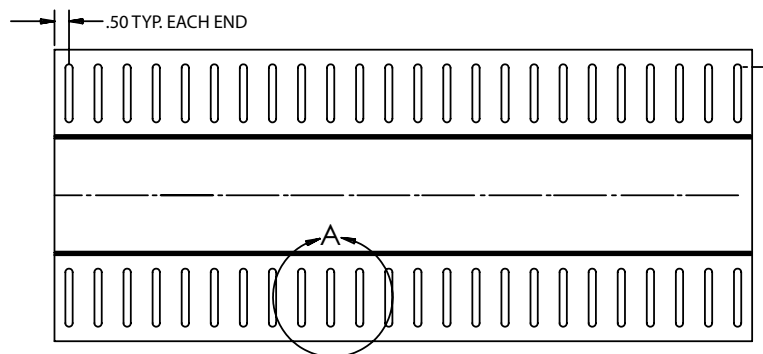

# INNOVATION, SERVICE, QUALITY

www.BuildStrong.com • 1-866-372-6384





# RESILIENT FURRING CHANNEL



CLIPS

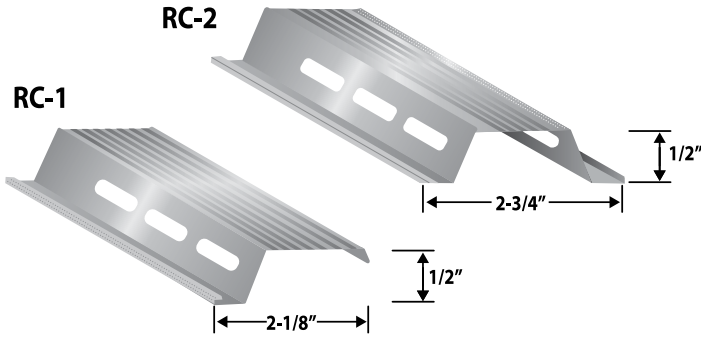

### PRODUCT DATA:

- RC-1: Single Leg
- RC-2: Double Leg
- Gauge: Standard 25 gauge conforming to ASTM A-653 and C-645
- Lengths: 12' 0" stock length
- RC-1: Screw attachment, one side only
- RC-2: Screw attachment, both sides

### USES:

- Used as cross furring members for resilient attachment of gypsum wallboard or lath on ceilings and partitions
- Decreased sound transmission through wall partitions and ceilings up to 13%

Product	Length	Wt./Ft.	Pcs./Ctn/	Ft./Ctn.
RC-1	12'	0.20	40	480
RC-2		0.24		

### SUPREME TESTED ASSEMBLIES

All acoustical data was independently tested by Riverbank Acoustical Laboratories. Riverbank Acoustical is a nationally recognized company accredited by the National Institute of Standards and Technology (NIST) through the National Voluntary Laboratory Accreditation Program (NVLAP).

RiverbankAcoustical

L A B O R A T O R I E S

### PARTITION SPECIFICATIONS

Partition Type	Side A	SideB	Gypsum Type	Insulation Type	Stud Spacing	STC Rating
1	1 layer	1 layer	5/8" Type X	-	24" oc	38
2	1 layer	1 layer	5/8" Type X	R-11 insulated	24" oc	47
3	1 layer	1 layer on RC-1	5/8" Type X	R-11 insulated	24" oc	52
4	2 layers	2 layers on RC-1	5/8" Type X	R-11 insulated	24" oc	61

### TYPICAL RC-1 INSTALLATION INSTRUCTIONS FOR WALLS

- Bottom RC-1 installed with mounting leg turned up, spaced 2" up from top track leg.
- Top RC-1 installed with mounting leg turned down, spaced 6" down from track leg.
- Middle RC-1 installed with mounting leg turned down, spaced 24" apart.
- Please reference Gypsum Association's GA-216 guidelines.

### TYPICAL RC-1 INSTALLATION INSTRUCTIONS FOR CEILINGS

- When RC-1 is installed on a ceiling, it should be installed perpendicular to the joists.
- RC-1 should be installed on ceilings with the open side facing the same direction across the entire ceiling.
- RC-1 on ceilings should be install with maximum of 6" spacing out from a wall.
- 16" OC joist spacing use 24" RC-1 spacing. 24" OC joist spacing use 16" RC-1 spacing.
- RC-1 can be overlapped at a support location with a minimum of 4" overlap.
- No more than two 5/8" gypsum boards should be fastened to an RC-1 channel with a maximum load of 5 lbs per SF.

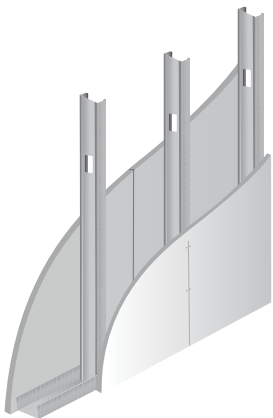

**Partition Type 1**  
38 STC  
3 5/8" Stud

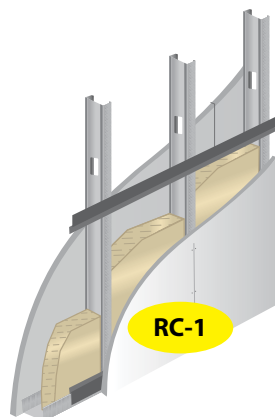

**Partition Type 3**  
52 STC  
3 5/8" Stud

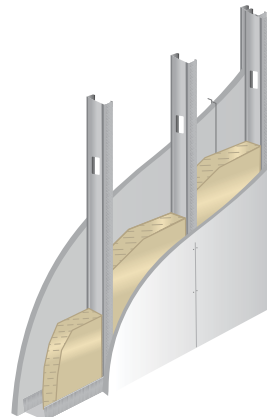

**Partition Type 2**  
47 STC  
3 5/8" Stud

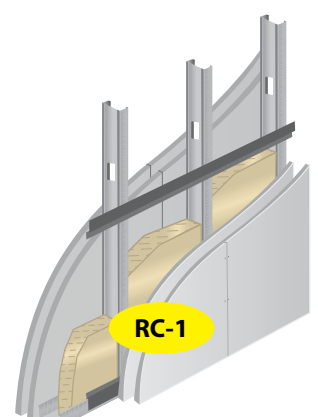

**Partition Type 4**  
61 STC  
3 5/8" Stud



INNOVATION, SERVICE, QUALITY

www.BuildStrong.com • 1-866-372-6384



## U-CHANNEL (CRC)

### PRODUCT DATA:

- Available in galvanized steel meeting ASTM A-1003 or hot-dipped galvanized steel meeting ASTM A-653, G60.
- Lengths: 16' stock length. (Other lengths available)

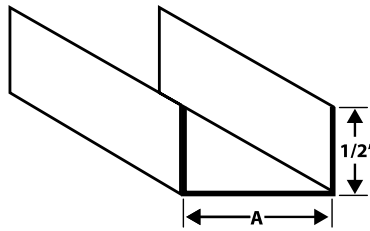

### USES:

- Bridging, (lateral support) in walls carrying axial and/or wind loads.
- Bracing studs at door bucks and furring for ceilings.
- Used in conjunction with metal lath and plaster in partitions, ceilings, column and beam enclosures, etc.

## U-CHANNEL (CRC) SECTION PROPERTIES

Section	Design Thickness (in)	Gross						Effective Properties 33 ksi			
		Area (in <sup>2</sup> )	Weight (lb/ft)	I <sub>x</sub> (in <sup>4</sup> )	R <sub>x</sub> (in)	I <sub>y</sub> (in <sup>4</sup> )	R <sub>y</sub> (in)	I <sub>x</sub> (in <sup>4</sup> )	S <sub>x</sub> (in <sup>3</sup> )	M <sub>a</sub> (in-k)	V <sub>a</sub> (lb)
CRC-075	0.0566	0.087	0.30	0.007	0.288	0.002	0.155	0.007	0.019	0.45	315
CRC-150	0.0566	0.129	0.44	0.039	0.547	0.003	0.144	0.039	0.052	1.22	840
CRC-200	0.0566	0.157	0.54	0.079	0.079	0.003	0.136	0.079	0.079	1.87	1190
CRC-250	0.0566	0.186	0.63	0.139	0.866	0.003	0.128	0.139	0.111	2.64	1540

- Notes:
1. Minimum deliverable base metal thickness is 95% of design thickness.
  2. Inside bend radius taken as 3/32"
  3. Effective properties based on F<sub>y</sub> = 33ksi
  4. For deflection calculations, use the effective moment of inertia

## DRYWALL FURRING CHANNEL

### PRODUCT DATA:

- Available in 7/8" and 1-1/2" sizes.
- Gauge: Standard 25 through 12 gauges.
- Lengths: 12' 0": stock length, (other lengths available).
- Consult Telling Industries' light gauges structural framing and accessories brochure for structural properties and span tables

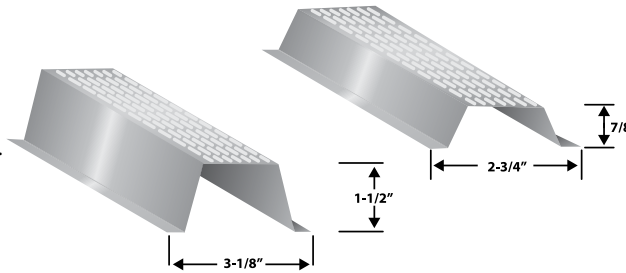

### USES:

- Conventional accessory components for use in furring out ceilings and masonry walls. Knurled face prevents screw "ride" when attaching gypsum wallboard.
- 1-1/2" DWFC is economical with respect to furring walls with electrical boxes, (no need to set into concrete).

## (ZFC) Z-FURRING CHANNEL

### PRODUCT DATA:

- Available in hot-dipped galvanized steel conforming to ASTM A-653 and C-645
- Gauges: Standard 25 gauge, (available in 20, 18, and 16 gauge upon request)
- Lengths: Standard 10' and 8'6" lengths, (other lengths available upon request)

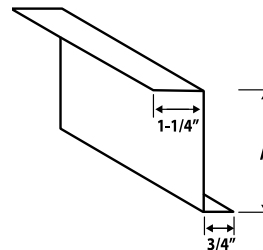

Product	(A) in. Size	25 Ga. Wt./Ft.
Z-100	1.00	0.195
Z-150	1.50	0.225
Z-200	2.00	0.260

## (CLT) CUSTOM LEG TRACK

### PRODUCT DATA:

- Designation: CLT or VST width x gauge
- Widths: Multiple sizes and gauges available
- Gauge: Multiple sizes available
- Lengths: Standard 10'

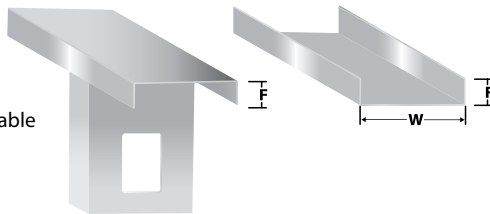

### USES:

- CLT used for standard built construction with channel or bracing attached within 2' of track member to each stud
- For attachment at top of infill curtain wall systems to primary frame; allows for one half inch of live load deflection or settlement of the primary frame without transferring the load to the exterior wall while bracing the wall against lateral forces
- Variable width and height for track-in-track application such as panel construction

## (WS) WEB STIFFENERS

### PRODUCT DATA:

- Designation: WS W x F x gauge
- Length: 4, 6, 7-1/4, 8, 9-1/4, 10, 12 inch
- Galvanized finish
- For axial capacities contact Telling Industries Engineering

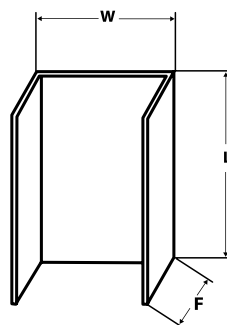

### USES:

- For web reinforcement of C shaped framing members
- Allow transfer of axial loads through joists at bearing conditions of platform frames



**AREA SEPARATION WALL** assemblies are designed for use in multi-family, multi-story townhouses as a firewall with a total height up to 50 feet. Because it is constructed using gypsum board, the assembly is easy to erect and secure, meets all building code requirements, and provides economical fire protection and sound control. Telling's Area Separation Wall utilizes H studs as referenced in UL wall assemblies U336, U347, U366, & U375.

### Aluminum Angle Clip

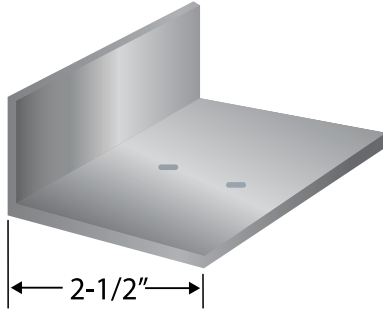

### C-Track, Cap, Edge or End Closure

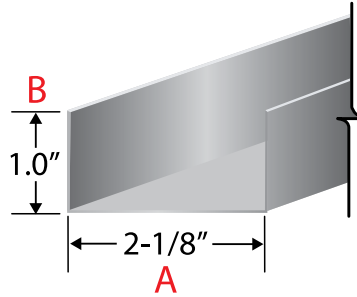

### H-Stud, 25-Gauge

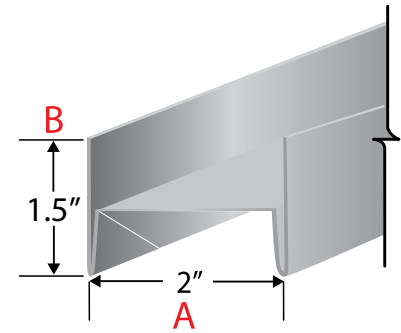

### C TRACK PRODUCT OFFERING

Section	Web (A) inches	Leg (B) inches	Coatings
213ASW-AST100-18	2.125"	1.0"	G40 standard. G60 & G90 with upcharge

### TRACK SECTIONAL PROPERTIES

Section	Design Thickness (in)	Min Base Steel Thickness (in)	Fy Yield Stress (ksi)	Weight (lb/ft)	Cross Sectional Area (in <sup>2</sup> )	Moment of Inertia about X-X axis I <sub>xx</sub> (in <sup>4</sup> )	Radius of Gyration R <sub>x</sub> (in)	Moment of Inertia about Y-Y axis I <sub>yy</sub> (in <sup>4</sup> )	Radius of Gyration R <sub>y</sub> (in)
213ASW-AST100-18	0.0188"	0.0179"	33	0.26	0.075	0.054	0.847	0.008	0.319

### H STUD PRODUCT OFFERING

Section	Web (A) inches	Flange (B) inches	Coatings
200ASW-HS200	2.0"	2.25"	G40 standard. G60 & G90 with upcharge

### H STUD SECTIONAL PROPERTIES

Section	Design Thickness (in)	Min Base Steel Thickness (in)	Fy Yield Stress (ksi)	Weight (lb/ft)	Cross Sectional Area (in <sup>2</sup> )	Moment of Inertia about X-X axis I <sub>xx</sub> (in <sup>4</sup> )	Radius of Gyration R <sub>x</sub> (in)	Moment of Inertia about Y-Y axis I <sub>yy</sub> (in <sup>4</sup> )	Radius of Gyration R <sub>y</sub> (in)
200ASW-HS200	0.0188"	0.0179"	33	0.70	0.205	0.185	0.952	0.118	0.760

### C TRACK

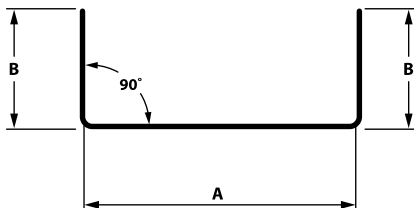

### H STUD

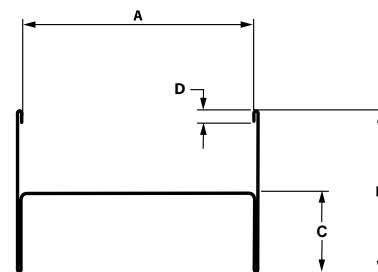

For more information, please contact Telling Industries Technical Services at 1-866-372-6384.

## LIGHT GAUGE METAL FRAMING ACCESSORIES: SHAFTWALL SYSTEM: CT STUD & J TRACK

Shaftwall Systems are used to aid in the construction of elevator shafts, mechanical shafts, stairwells, air return shafts and horizontal membranes. The system is designed to use with 1" gypsum board. Telling's Shaftwall is available in 2 1/2", 4", or 6" sizes. Shaftwall is available in 18, 33 and 40 mil thicknesses. Shaftwall design utilizes CT (also called CH) studs as referenced in the UL wall assembly U415.

### CT STUD PRODUCT OFFERING

Section	Web (in)	Min Thickness (in)	Design Thickness (in)	Fy (ksi)
CT-18	2.5", 4.0", 6.0"	0.0179	0.0188	33
CT-33	2.5", 4.0", 6.0"	0.0329	0.0346	33
CT-40	2.5", 4.0", 6.0"	0.0380	0.0400	33

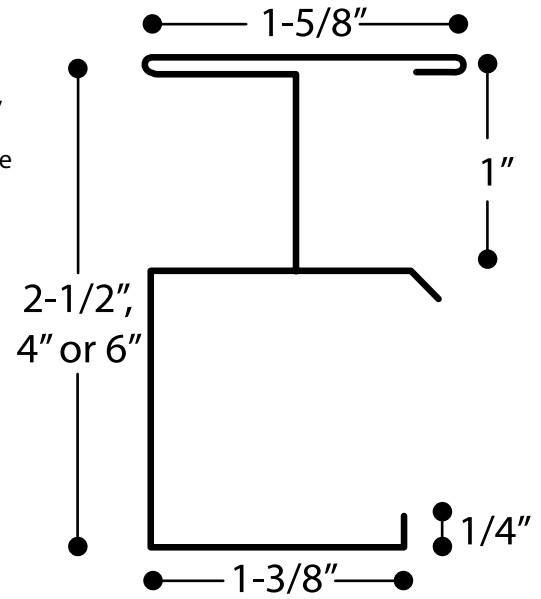

### CT STUD SECTION PROPERTIES

Section	Min Thickness (in)	Design Thickness (in)	Fy (ksi)	Weight (lb/ft)	Area (in <sup>2</sup> )	Ixx (in <sup>4</sup> )	Sx(C) (in <sup>3</sup> )	Sx(T) (in <sup>3</sup> )
250CT-18	0.0179"	0.0188"	33	0.47	0.118	0.132	0.095	0.118
400CT-18	0.0179"	0.0188"	33	0.58	0.015	0.374	0.171	0.207
600CT-18	0.0179"	0.0188"	33	0.72	0.181	0.957	0.299	0.347
250CT-33	0.0329"	0.0346"	33	0.82	0.218	0.242	0.175	0.217
400CT-33	0.0329"	0.0346"	33	1.02	0.267	0.687	0.341	0.380
600CT-33	0.0329"	0.0346"	33	1.26	0.333	1.759	0.543	0.637
250CT-40	0.0380"	0.0400"	33	0.99	0.291	0.273	0.253	0.192
400CT-40	0.0380"	0.0400"	33	1.19	0.351	0.811	0.476	0.353
600CT-40	0.0380"	0.0400"	33	1.47	0.431	2.142	0.827	0.628

### CT STUD & J TRACK LIMITING WALL HEIGHTS

Limiting Wall Heights for CT Studs & J Track Shaftwall 1-Hour Fire Rated Assemblies

Section	Design Thickness (in)	5 psf				7.5 psf				10 psf			
		L/120	L/180	L/240	L/360	L/120	L/180	L/240	L/360	L/120	L/180	L/240	L/360
250CT-18	0.0188"	11'-7" f	11'-4"	10'-6"	9'-0"	9'-5" f	9'-5" f	8'-11"		8'-2" f	8'-2" f	7'-10"	
400CT-18	0.0188"	14'-6" f	14'-6" f	13'-9"	12'-1"	11'-10" f	11'-10" f	11'-10" f	10'-5"	9'-3" s	9'-3" s	9'-3" s	9'-3" s
600CT-18	0.0188"	16'-11" f	16'-11" f	16'-11" f	16'-3"	13'-10" f	13'-10" f	13'-10" f	13'-10" f	12'-0" f	12'-0" f	12'-0" f	12'-0" f
250CT-33	0.0346"	15'-9"	13'-9"	12'-6"	10'-11"	13'-9"	12'-0"	10'-11"	9'-6"	12'-6"	10'-11"		8'-7"
400CT-33	0.0346"	21'-7"	18'-10"	17'-2"	15'-0"	18'-9" f	16'-6"	15'-0"	13'-1"	16'-2" f	15'-0"	13'-7"	11'-10"
600CT-33	0.0346"	27'-10" f	25'-3"	22'-11"	20'-1"	22'-9" f	22'-1"	20'-1"	17'-6"	19'-5" f	19'-5" f	18'-3"	15'-11"
250CT-40	0.0400"	16'-11"	14'-9"	13'-5"	11'-9"	14'-9"	12'-11"	11'-9"	10'-2"	13'-5"	11'-9"	10'-7"	9'-2"
400CT-40	0.0400"	23'-4"	20'-4"	18'-6"	16'-2"	20'-4"	17'-9"	16'-2"	14'-1"	18'-6"	16'-2"	14'-8"	12'-10"
600CT-40	0.0400"	30'-11"	27'-1"	24'-8"	21'-7"	27'-1"	23'-9"	21'-7"	18'-11"	24'-7" f	21'-7"	19'-8"	17'-3"

**NOTES:**

1. Allowable composite limiting heights are calculated using ICC-ES-AC86-2012
2. "f" indicates flexural stress controls the allowable wall height
3. "s" indicates the end reaction controls the allowable wall height
4. Wall Construction was: Type X 5/8" thick Gypsum board, & #6 screws
5. Stud Spacing was 24" on center
6. 600CT-33 and 600CT-40 assemblies require a 6 in screw spacing for the gypsum board along the top & bottom track.



# TITAN HEADER SYSTEM



## ONE PIECE HEADER FRAMING SYSTEM

The Titan one piece wide flange header and jamb offers a better solution for framing multiple openings than the conventional lay-in or boxed headers.

### SYSTEM ADVANTAGES:

- No more built-up jambs and headers
- Saves over 50% in installation and material over conventional framing
- Substantial reduction in number of screws and labor
- Header quickly attaches to jamb with fully tested, pre-drilled Titan Header Clip

SEE THE VIDEO



### MATERIAL

#### SPECIFICATIONS:

ASTM 1003, Grade 50

#### PRODUCT AVAILABILITY:

Titan Header & Jamb

- **Web:** 3-5/8", 4", 6", & 8"
- **Flanges:** 2-1/2" & 3"
- **Lip/Return:** 7/8"
- **Thickness:**
  - 54 mils (16ga) 50KSI
  - 68 mils (14ga) 50KSI
  - 97 mils (12ga) 50KSI

#### TITAN HEADER CLIP

- **Length:** 3-5/8", 6" & 8" x 1-1/2"
- **Web:** 2.5", 3.0"
- **Thickness:** 68 mils (14ga) 50KSI

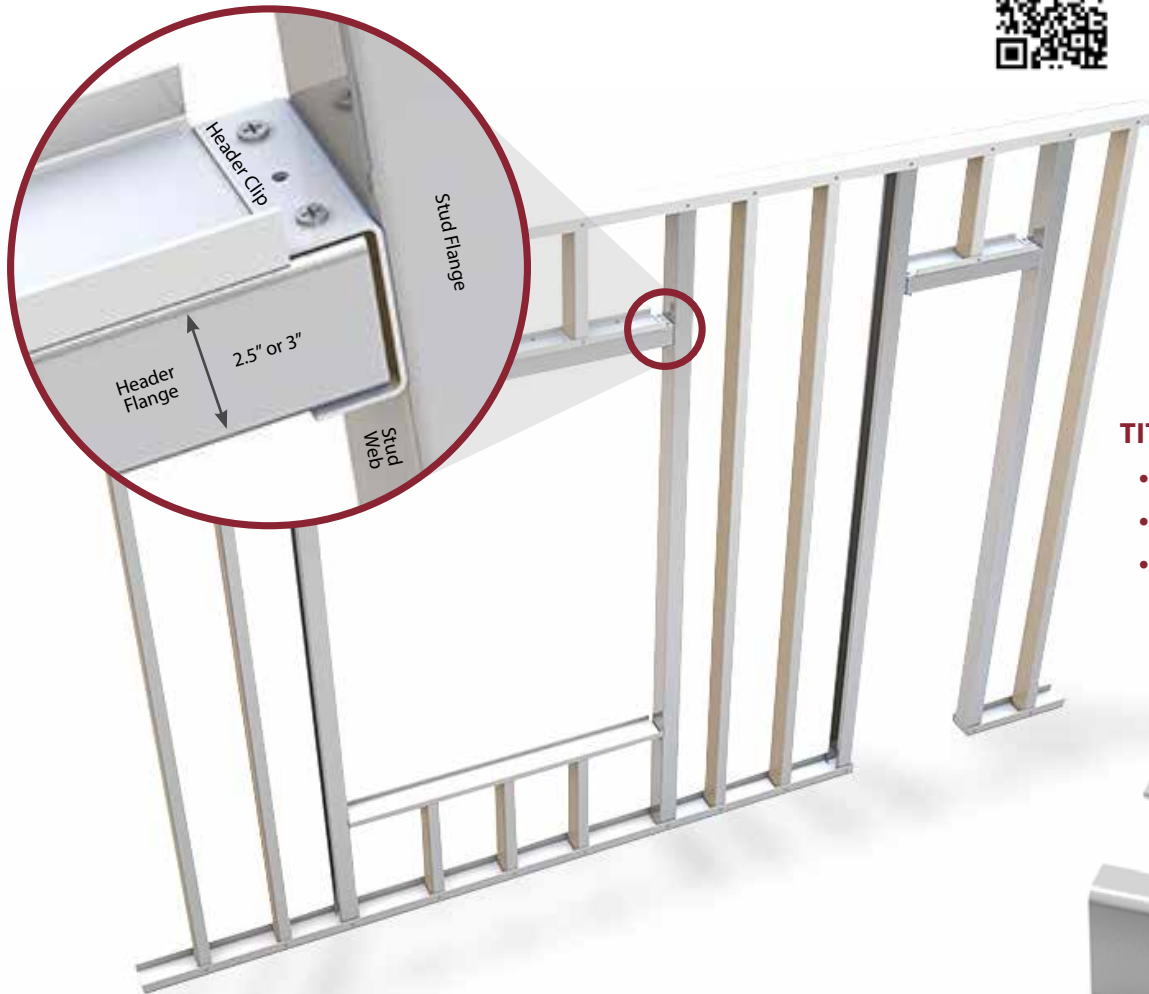

Header Size		Titan Header Clip Allowable Load Capacity		
Web Depth (in)	Flange Width (in)	Vertical Load (lbs)	Horizontal Load (lbs)	
3-5/8	2-1/2	4	1140	1520
		6	1140	1740
		8	1140	1930
		4	1140	1520
3-5/8	3	6	1140	1740
		8	1140	1930
		4	1140	1520
		6	1140	1740

1. Attach THC (clip) with (4) #10-16 screws to Titan Jamb and Titan Header respectively.
2. Listed values are based on 54 mil (16 gauge), 50 ksi Titan Header and Jamb.
3. For combined vertical and horizontal, use linear interaction equation.
4. Tabulated values are based on testing in accordance with the requirements of ICC-ES AC261.
5. Allowable loads are calculated with Safety factor,  $\Omega$ , of 2.711 for vertical and 2.606 for horizontal.
6. Safety factors are calculated in accordance with the provisions of Section F1 of AISI S100 with the statistical parameters given in AC261.



## INNOVATION, SERVICE, QUALITY

www.BuildStrong.com • 1-866-372-6384





# T-RULE TECHNOLOGY



US PATENT 11,002,011

### MARKET NEED:

- Some metal framing must be custom cut to length at the job site.
- The inaccuracy of stretching a tape measure across a metal framing component, marking it, then field cutting or track and stud layout can lead to undesirable length variation and increased install time.
- If the length variation is too excessive, the field cut metal framing components may need to be scrapped and new pieces re-cut, resulting in higher material costs.

### SOLUTION:

- Telling has a patent pending invention to add ruler marking to metal framing stud & track to simplify field cutting and wall layouts.
- The ruler markings will be permanently applied via etching/embossing.

### PRODUCT INFO:

- Readily available on 30mil & 33mil traditional drywall studs at no upcharge.
- The marking will be in 1/4", 1/2" & 1" increments.
- Available upon request for 18ga & 16ga studs for a modest upcharge.
- Standard: 2ft of etched ruler marking.
- Upon request: etch entire length of stud for a modest upcharge.
- Track is coming soon!

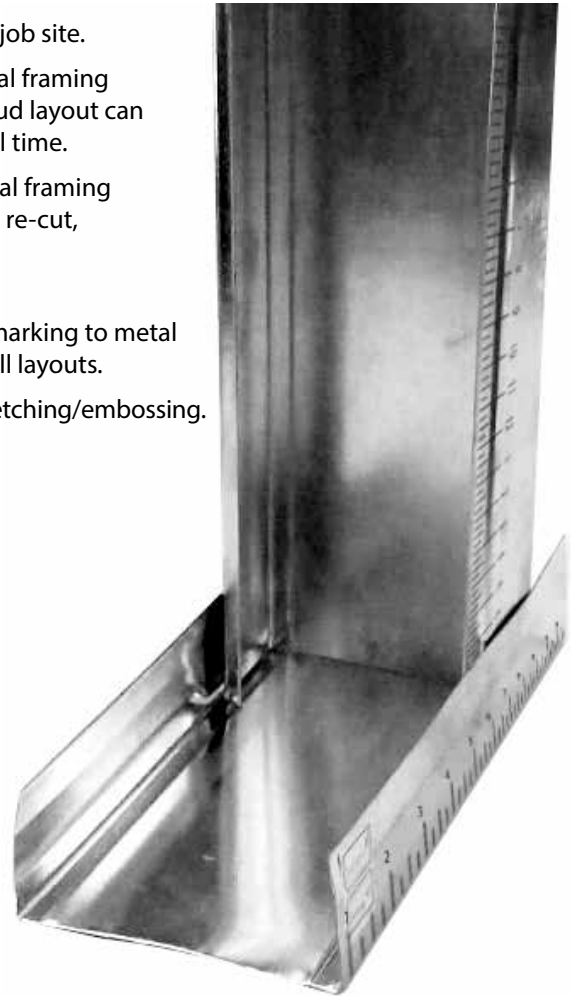
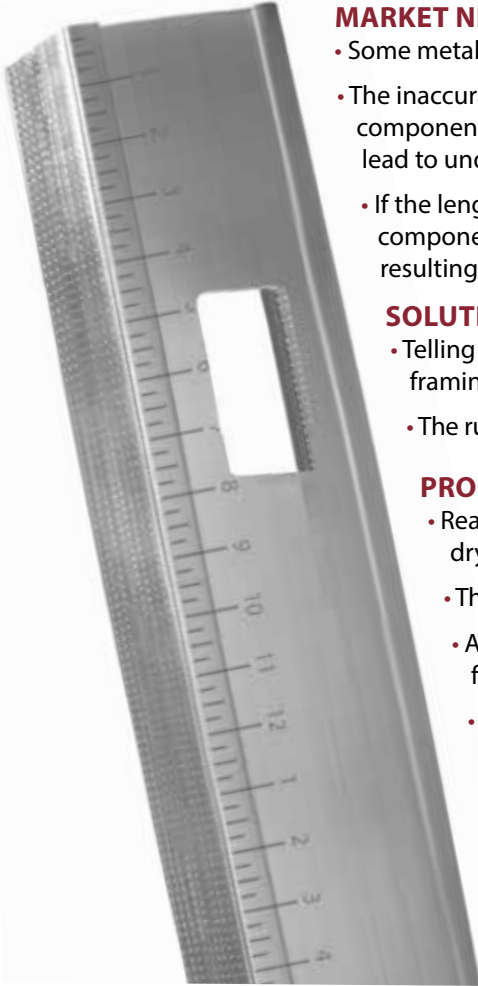

**NO MORE MEASURING TAPE! TRUE-RULE TECHNOLOGY MAKES CUTTING STUD AND TRACK A BREEZE!**



SEE THE VIDEO



## INNOVATION, SERVICE, QUALITY

www.BuildStrong.com • 1-866-372-6384





# TRADITIONAL FRAMING



Telling offers a full product line of traditional full gauge metal framing for interior non-load bearing drywall applications. Our patent True-Rule technology can be applied to most Traditional Stud options.

Telling's Traditional Metal Framing is listed in the International Code Compliance Evaluation Service Report (ICC-ESR 2281) verifying load bearing light gauge steel framing products are code compliant. This report and 3rd party quality audit validation provides evidence that both our products, and our quality processes meet or exceed International Building Code standards. Telling's Traditional Metal Framing complies with AISI S100, ASTM A653, ASTM A1003, ASTM C645, ASTM C754. FBC Florida Building Code 2023 compliant per ICC ESR 2281.

## TRADITIONAL INTERIOR FRAMING PROPERTIES & DATA

Thickness Nomenclature	Min Base Metal Thickness (in)	Design Thickness (in)	Min Yield Strength (ksi)	Standard Galvanization	Web Sizes (in)	Stud Flange / Leg Sizes (in)	Track Flange / Leg Sizes (in)	Design Inside Corner Radii (in)
18 mil	0.0179"	0.0188"	33 ksi	G40	1-5/8", 2.5", 3.5", 3-5/8", 4"	1-1/4"	1-1/4", 1.5"	0.0843"
27 mil	0.0269"	0.0283"	33 ksi	G40	1-5/8", 2.5", 3.5", 3-5/8", 4", 5.5", 6"	1-1/4"	1-1/4", 1.5"	0.0796"
30 mil	0.0296"	0.0312"	33 ksi	G40	1-5/8", 2.5", 3.5", 3-5/8", 4", 5.5", 6"	1-1/4"	1-1/4", 1.5"	0.0781"
33 mil	0.0329"	0.0346"	33 ksi	G40	1-5/8", 2.5", 3.5", 3-5/8", 4", 5.5", 6", 7-1/4", 8"	1-1/4", 1-3/8", 1-5/8", 2"	1-1/4", 1.5", 2"	0.0764"

Return lip is 0.1875" for all traditional interior framing studs.

G60 & G90 available for an upcharge.

Drywall max Web 6"  
33mil structural max web is 8".

Drywall max Leg 1-1/4".  
33mil structural max Leg is 2".  
1-5/8" web has max 2" leg on press brake.

Drywall max Leg 1-1/4".  
33mil Structural max Leg is 2"  
1.5" is Press Brake only.

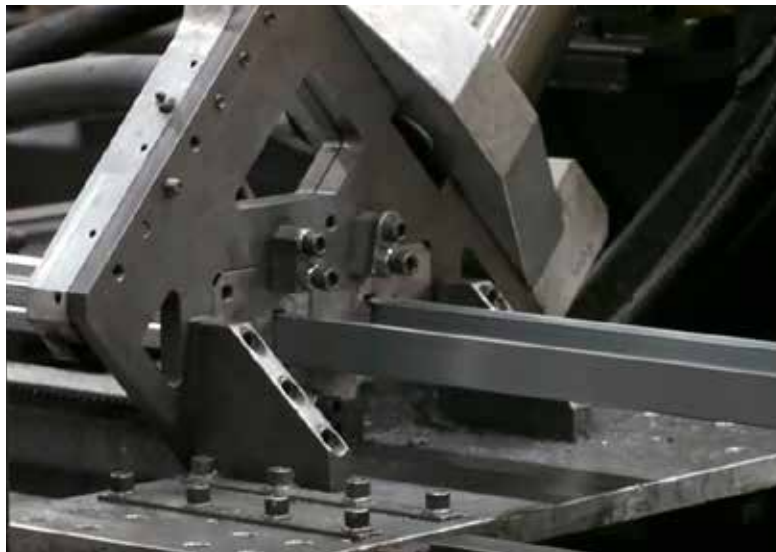

Steel Framing Alliance™



# INNOVATION, SERVICE, QUALITY

www.BuildStrong.com • 1-866-372-6384





# STRUCTURAL FRAMING



Telling offers a full product line of Structural Metal Framing for load bearing applications. Telling's Structural Metal Framing is listed in the International Code Compliance Evaluation Service Report (ICC-ESR 2281) verifying load bearing light gauge steel framing products are code compliant. This report and 3rd party quality audit validation provides evidence that both our products, and our quality processes meet or exceed International Building Code standards. Telling's Structural Metal Framing complies with AISI S100, ASTM A653, ASTM A1003, ASTM C645, ASTM C754, ASTM C1007. FBC Florida Building Code 2023 compliant per ICC ESR 2281.

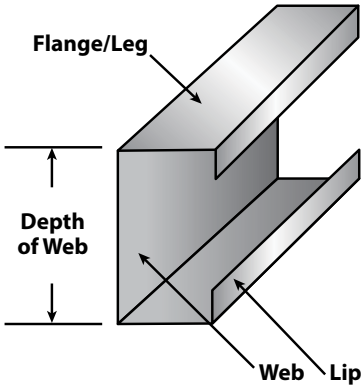

## INTERNATIONAL CODE COUNCIL

### INTERNATIONAL BUILDING CODE COMPLIANT

- ICC ESR 2281
  - ICC-ES Certified
  - Internationally recognized
- Verified by ICC Certified Inspectors at all facilities
  - Cambridge, Ohio
  - Osceola, Arkansas
  - Windsor, Connecticut

## ASTM INTERNATIONAL

### TELLING MEETS OR EXCEEDS ALL APPLICABLE STRUCTURAL FRAMING STANDARDS.

- A 1003** - Standard Specifications for Steel Sheet, Carbon, Metallic and Nonmetallic - Coated for Cold-Formed Framing Members
- A 653** - Standard Specifications for Steel Sheet, Zinc-Coated (Galvanized) or Zing-Iron Alloy - Coated (Galvannealed) by the Hot-Dip Process
- C 645** - Standard Specifications for Nonstructural Steel Framing Members
- C 754** - Standard Specifications for Installation of Steel Framing Members to Receive Screw - Attached Gypsum Panel Products
- C 955** - Standard Specifications for Load-Bearing (Transverse and Axial) Steel Studs, Runners, (Tracks), and Bracing or Bridging for Screw Application of Gypsum Panel Products and Metal Plaster Bases
- C 1007** - Standard Specification for Installation of Load Bearing (Transverse and Axial) Steel Studs and Related Accessories

## THICKNESS - STEEL COMPONENTS

Mill Thickness (mils)	Design Thickness (in)	Reference Only Gauge Number	Color Coding
33	0.0346	20 - Structural	White
43	0.0451	18	Yellow
54	0.0566	16	Green
68	0.0713	14	Orange
97	0.1017	12	Red
118	.1242	10	Blue

Section	Flange Width	Design Stiffening Lip Length (in)
S137	1-3/8"	0.375
S162	1-5/8"	0.5
S200	2"	0.625
S250	2-1/2"	0.625
S300	3"	0.75
S350	3-1/2"	1.0

Minimum Thickness represents 95% of the design thickness and is the minimum acceptable thickness delivered to the job site based on Section A2.4 of AISI S100-07.



Steel Framing Alliance™



# INNOVATION, SERVICE, QUALITY

www.BuildStrong.com • 1-866-372-6384



## SUPREME STUD AND TRACK CERTIFICATION

Supreme products have an industry standard, four-part identification code that identifies the web depth, flange width, style, and mil thickness. For example: 362SFS125-D20 = 3-5/8" web Supreme Framing Stud 1-1/4" leg at 20eq thickness.

The Supreme Framing System offers all the benefits of traditional flat steel studs and track. It consists of high strength metal framing with a design that achieves equal or better performance by using superior 57 ksi yield strength and thinner steel.

All inspections and testing for the Supreme Steel Framing System Association (SSFSA) are provided by a third-party certification agency where products are required to be audited to ensure consistent quality and compliance to ASTM C645, C955, IBC Codes, and AISI S100-07 standards.

## SUPREME HOLE GEOMETRY

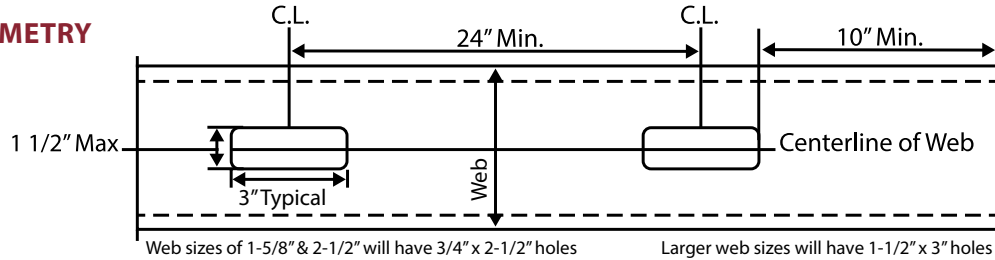

Additional Supreme Framing System information available at [www.SSFSA.com](http://www.SSFSA.com)

## SUPREME STUD PROFILES

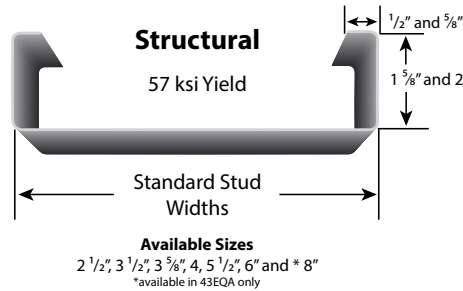
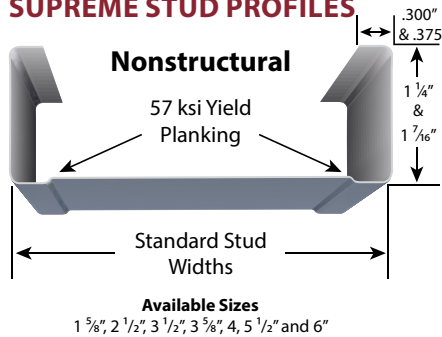

## SUPREME STUD STIFFENING LIP LENGTH

Nomenclature	Flange/Leg (in)	Stiffening Lip Length (in)
SFS125-D25	1-1/4"	0.300"
SFS125-D20	1-1/4"	0.375"
SFS144	1-7/16"	0.375"
SFS162	1-5/8"	0.500"
SFS200	2"	0.625"

Supreme Stud Stiffening Lip Length remains constant with various web sizes

## SUPREME STUD

Thickness Nomenclature	Min Base Metal Thickness (in)	Design Thickness (in)	Min Yield Strength (ksi)	Standard Galvanization	Web Sizes (in)	Stud Flange / Leg Sizes (in)	Track Flange / Leg Sizes (in)	Design Inside Corner Radii (in)
D25	0.0147"	0.0155"	50 or 57 ksi	G40	1-5/8", 2.5", 3.5", 3-5/8", 4", 5.5", 6"	1-1/4"	1-1/4" and 1-1/2"*	0.0860"
D20	0.0179"	0.0188"	57 ksi	G40	1-5/8", 2.5", 3.5", 3-5/8", 4", 5.5", 6"	1-1/4" and 1-7/16"	1-1/4" and 1-1/2"*, 2"*	0.0844"
30EQD	0.0223"	0.0235"	57 ksi	G40	1-5/8", 2.5", 3.5", 3-5/8", 4", 5.5", 6"	1-1/4" and 1-7/16"	1-1/4", 1-1/2" and 2"*	0.0820"

D = Drywall / Non Structural, S = Structural

Higher galvanization available

\* = Track height to weight ratio exceeds AISI S100 guidelines

## SUPREME DEEP LEG TRACK

Thickness Nomenclature	Min Base Metal Thickness (in)	Design Thickness (in)	Min Yield Strength (ksi)	Standard Galvanization	Track Web Sizes (in)	Track Flange / Leg Sizes (in)	Gap (in)
D20	0.0179"	0.0188"	57 ksi	G40	2.5", 3.5", 3-5/8", 4", 5.5", 6"	2", 2.5", 3"	2" leg = 1/2" gap 2.5" leg = 3/4" gap 3.0" leg = 1.0" gap
30EQD	0.0223"	0.0235"	57 ksi	G40	2.5", 3.5", 3-5/8", 4", 5.5", 6"	2", 2.5", 3"	

D = Drywall / Non Structural, S = Structural





**THE LEADER  
IN METAL  
FRAMING  
INNOVATION** BUILDSTRONG.COM

Technical information and CAD drawings available at  
[www.BuildStrong.com](http://www.BuildStrong.com) | **ARCAT**



**CORPORATE HEADQUARTERS:** 4420 Sherwin Road Willoughby, OH 44094

**E-mail:** [sales.corp@tellingindustries.com](mailto:sales.corp@tellingindustries.com) | **Phone:** 440-974-3370 | **Toll Free:** 866- 372-6384 | **Fax:** 440-974-3408

**MIDWEST FACILITY:** 2105 Larrick Road Cambridge, OH 43725

**E-mail:** [sales.corp@tellingindustries.com](mailto:sales.corp@tellingindustries.com) | **Phone:** 740-435-8900 | **Toll Free:** 866-357-8837 | **Fax:** 740-435-8915

**NORTHEAST FACILITY:** 1050 Kennedy Road Windsor, CT 06095

**E-mail:** [sales.corp@tellingindustries.com](mailto:sales.corp@tellingindustries.com) | **Phone:** 860-731-7975 | **Toll Free:** 866- 372-6384 | **Fax:** 860-731-7976

**MIDSOUTH FACILITY:** 1400 Southwire Drive Osceola, AR 72370

**E-mail:** [sales.corp@tellingindustries.com](mailto:sales.corp@tellingindustries.com) | **Phone:** 870-563-6065 | **Toll Free:** 888-711-3124

**SOUTHEAST FACILITY:** 1200 W Martin Luther King Blvd, Plant City, FL 33563

**E-mail:** [sales.corp@tellingindustries.com](mailto:sales.corp@tellingindustries.com) | **Phone:** 440-974-3370 | **Toll Free:** 866- FRAME-TI (372-6384) | **Fax:** 440-974-3408

**ENGINEERING AND DESIGN SERVICES (QUOTED) & TECHNICAL SERVICES (FREE)**

[technical@tellingindustries.com](mailto:technical@tellingindustries.com)

1-866-372-6384  
440-478-8625 (direct)

Updated 12-3-24