

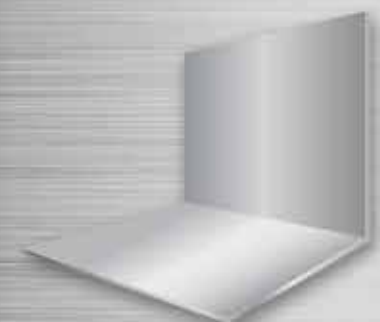

PREMIUM CLIPS



THE LEADER
IN METAL
FRAMING
INNOVATION



BUILDSTRONG.COM

TABLE OF CONTENTS

Introduction: Types of Clips	2
TRC A Series - Rigid Clips.....	3-4
TRC B Series - Rigid Clips	5-6
TRC A Series Line Drawings	7
TRC B Series Line Drawings.....	8
Custom Rigid Clips	9
T-Bridge - Bridge Clips.....	10
KB-Kwik-Back - Wall Support Clips.....	11
Titan Header Specialty Clips.....	12
Slide Clip - Verticlip SL - Exterior Head of Wall.....	13
Slide Clip - Verticlip SLD - Interior Head of Wall	14
Slide Clip - Verticlip SLB - Bypass Slab	15
Slide Clip - Verticlip SLS - Structure.....	16

TYPES OF CLIPS

Telling Industries manufactures an extensive line of Metal Framing Connectors and Clips. Standard gauges and sizes are complimented with specialized and custom fabricated Clips to meet all your Metal Framing needs. If your project needs connectors not shown in this catalog, please contact your inside sales rep or send an inquiry to www.buildstrong.com. All Telling products, including Metal Framing Connectors, are proudly made in the USA.

Bridge Clips: Attaches bridging such as True-Brace or CRC to each other and/or studs.



Rigid Clips: attaches stud/track to additional metal framing or structural components.

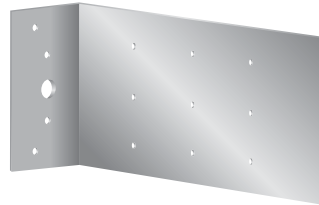

Custom Rigid Clips: for miscellaneous attachments of intersection framing components.

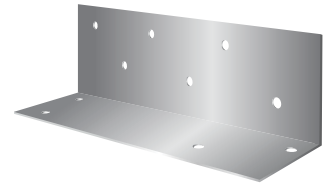
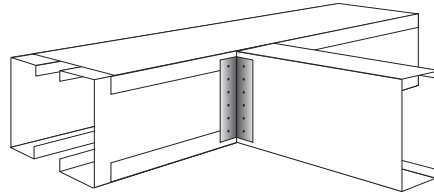

Backing Clips: clips that allows wood or metal to be affixed between studs as backing support for additional wall mounted fixtures such as cabinets & handrails.

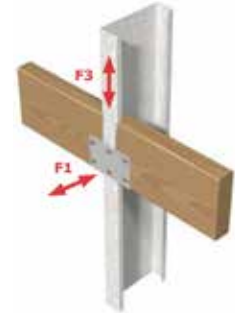

Specialty Clips: Titan Header Clips - used with the Titan Header Assembly to reduce door and window jamb construction build up.



Slide / Drift Clips: slotted with shoulder nut to allow for deflection.



TRC A Series Rigid Right Angle Clips

Predominately Used to Attach Metal Framing to Metal Framing

Section	Clip Thickness	Leg Length (in)	Clip Length (in)	BKT Quantity
TRC223	0.0538" (16ga)	2" x 2"	3.0"	150
	0.0677" (14ga)			
	0.0966" (12ga)			
TRC225	0.0538" (16ga)	2" x 2"	5.0"	120
	0.0677" (14ga)			
	0.0966" (12ga)			
TRC227	0.0538" (16ga)	2" x 2"	7.0"	100
	0.0677" (14ga)			
	0.0966" (12ga)			
TRC229	0.0538" (16ga)	2" x 2"	9.0"	75
	0.0677" (14ga)			
	0.0966" (12ga)			
TRC2211	0.0538" (16ga)	2" x 2"	11.0"	30
	0.0677" (14ga)			
	0.0966" (12ga)			

Stud Web Size

TRC223	3.5", 3-5/8, 4"
TRC225	5.5", 6"
TRC227	8"
TRC229	10"
TRC2211	12"

One 2" leg attaches to one Metal Framing component. Another 2" leg attached to another Metal Framing component. The Clip Length is design to fit inside or outside the web.

Stud Web Size

TRC133	3.5", 3-5/8, 4"
TRC143	3.5", 3-5/8, 4"
TRC145	5.5", 6"
TRC147	8"
TRC149	10"
TRC156	5.5", 6"
TRC1411	12"
TRC173	8", 10", 12"

- The 1.5" short leg attaches to structural components such as red iron or masonry.
- Long leg attaches to metal framing stud or track.
- The 4" width is standard for all TRC Series 1 clips.

TRC B Series Rigid Right Angle Clips

predominately used to attach Metal Framing to Metal Framing

Section	Clip Thickness	Leg Length (in)	Clip Length (in)	BKT Quantity
TRC133	0.0538" (16ga)	1.5" x 3"	3.0"	150
	0.0677" (14ga)			
	0.0966" (12ga)			
TRC143	0.0538" (16ga)	1.5" x 4"	3.5"	120
	0.0677" (14ga)			
	0.0966" (12ga)			
TRC145	0.0538" (16ga)	1.5" x 4"	5.5"	100
	0.0677" (14ga)			
	0.0966" (12ga)			
TRC147	0.0538" (16ga)	1.5" x 4"	7.5"	100
	0.0677" (14ga)			
	0.0966" (12ga)			
TRC149	0.0538" (16ga)	1.5" x 4"	9.5"	75
	0.0677" (14ga)			
	0.0966" (12ga)			
TRC1411	0.0538" (16ga)	1.5" x 4"	11.5"	30
	0.0677" (14ga)			
	0.0966" (12ga)			
TRC156	0.0538" (16ga)	1.5" x 5"	6.0"	50
	0.0677" (14ga)			
	0.0966" (12ga)			
TRC173	0.0538" (16ga)	1.5" x 7"	3.0"	50
	0.0677" (14ga)			
	0.0966" (12ga)			

*All Sales are subject to Telling's Terms & Conditions found at www.buildstrong.com. Please contact your Telling Sales Representative for further inquires.

Telling's line of Premium Rigid Clips Series firmly attach metal framing to metal framing components. These rigid clips are available in 3 gauges; 12, 14 and 16 and come standard with G60 code compliant coating and an optional G90 coating upgrade. Available in a multitude of standard and custom sizes. These clips are made in Telling's manufacturing plants in the USA.

TR223

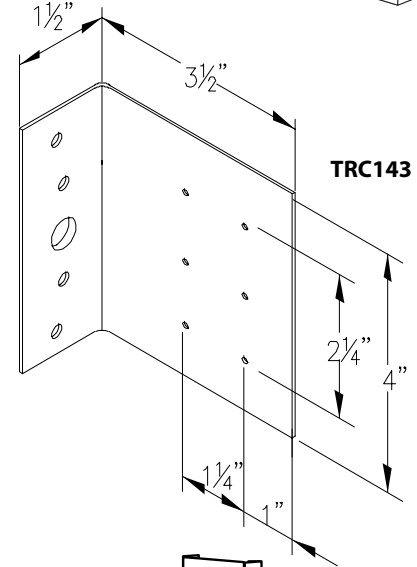
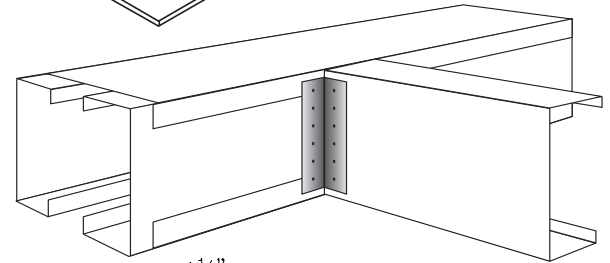
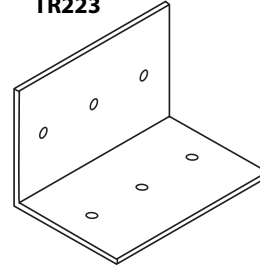

TRC143

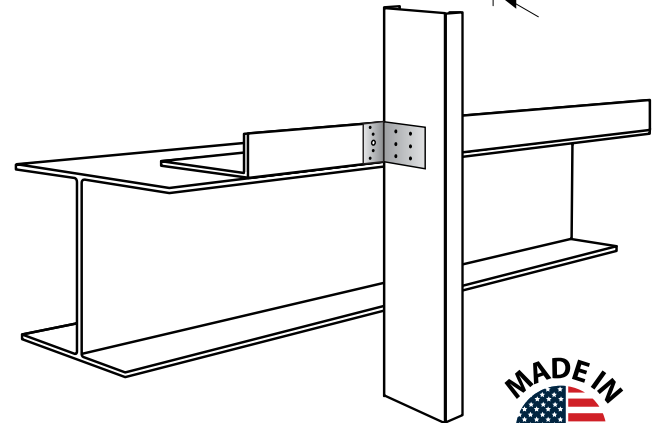

TELLING RIGID CLIP SHEAR CAPACITIES (LBS)

CLIP PART#	CLIP THK.	L(in)	"#10-16 SCREWS"	STUD		
				"33 mil (20 ga) (33ksi)"	"43 mil (18 ga) (33ksi)"	"54 mil (16 ga) (50ksi)"
				F1	F1	F1
TRC223	54	3	3	294	437	888
	68	3	3	294	437	888
	97	3	3	294	437	888
TRC225	54	5	3	424	631	1281
			5	624	929	1767
	68	5	3	424	631	1281
			5	624	929	1888
	97	5	3	424	631	1281
			5	624	929	1888
TRC227	54	7	3	474	705	1433
			7	989	1472	2475
	68	7	3	474	705	1433
			7	989	1472	2991
	97	7	3	474	705	1433
			7	989	1472	2991
TRC229	54	9	3	496	738	1500
			9	1359	2029	3183
	68	9	3	496	738	1500
			9	1359	2029	4010
	97	9	3	496	738	1500
			9	1359	2029	4122
TRC2211	54	11	3	507	755	1534
			11	1738	2587	3890
	68	11	3	507	755	1534
			11	1738	2587	4901
	97	11	3	507	755	1534
			11	1738	2587	5255

Table Notes:

1. The tabulated clip capacity values are based on the AISI Research Report PR18-4 "Load Bearing Clip Angle Design" phase II and accepted industry design standards.
2. The anchor strength to the support must be calculated separately, the minimum of the tabulated clip capacity and the anchor strength must be used. Anchor strength may be less than the tabulated clip capacity.
3. Appropriate interaction equation must be used for clips subjected to the combined shear tension and compression forces.

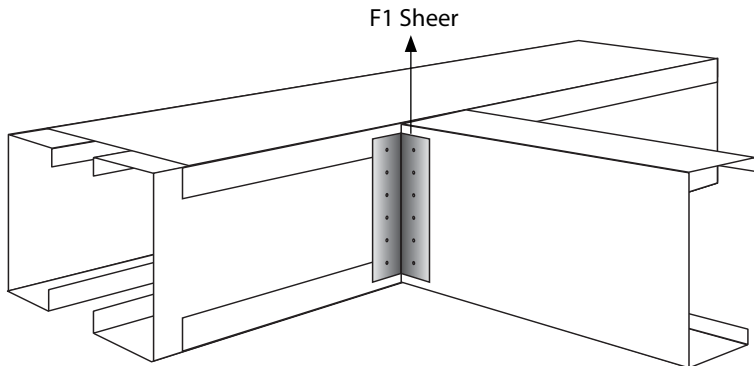

- Clip performance data lists allowable loads in the direction shown.
- ASTM A653 compliant

THIRD PARTY PE
CALCULATED AND
VALIDATED.



TELLING RIGID CLIP ALLOWABLE CAPACITIES (LBS)

PART#	CLIP THK.	Yield F(y)	Tensile	Length (in)	Buckling Lngth (A), in	#10-16 SCREWS	STUD								
							33 mil (20 ga)			43 mil (18 ga)			54 mil (16 ga)		
							F1	F2	F3	F1	F2	F3	F1	F2	F3
TRC133	54	50 ksi	65 ksi	3.0	1.0	4	242	137	702	360	137	702	732	137	702
	68	50 ksi	65 ksi	3.0	1.0	4	242	217	706	360	217	1007	732	217	1007
	97	50 ksi	65 ksi	3.0	1.0	4	242	443	706	360	443	1050	732	443	1753
TRC143	54	50 ksi	65 ksi	3.5	1.25	4	400	213	705	596	213	827	1100	213	827
					1.25	6	429	213	827	638	213	827	1100	213	827
	68	50 ksi	65 ksi	3.5	1.25	4	400	338	705	596	338	1052	1174	338	1185
					1.25	6	429	338	1060	638	338	1185	1174	338	1185
	97	50 ksi	65 ksi	3.5	1.25	4	400	689	705	596	689	1052	1211	689	2063
					1.25	6	429	689	1060	638	689	1578	1296	689	2063
TRC145	54	50 ksi	65 ksi	5.5	3.25	4	315	213	484	438	213	484	438	213	484
					2.0	6	481	213	635	713	213	635	713	213	635
	68	50 ksi	65 ksi	5.5	3.25	4	315	338	694	469	338	694	552	338	694
					2.0	6	481	338	911	716	338	911	898	338	911
	97	50 ksi	65 ksi	5.5	3.25	4	315	689	706	619	689	1052	788	689	1208
					2.0	6	481	689	1060	716	689	1578	992	689	1586
TRC147	54	50 ksi	65 ksi	7.5	5.25	4	258	213	370	271	213	370	271	213	370
					4.0	6	356	213	431	356	213	431	356	213	431
	68	50 ksi	65 ksi	7.5	5.25	4	258	338	530	342	338	530	342	338	530
					4.0	6	389	338	618	449	338	618	449	338	618
	97	50 ksi	65 ksi	7.5	5.25	4	258	689	706	385	689	923	488	689	923
					4.0	6	389	689	1060	579	689	1075	640	689	1075
TRC149	54	50 ksi	65 ksi	9.5	7.25	4	196	213	309	196	213	309	196	213	309
					6.0	6	237	213	343	237	213	343	237	213	343
	68	50 ksi	65 ksi	9.5	7.25	4	219	338	443	247	338	443	247	338	443
					6.0	6	299	338	492	299	338	492	299	338	492
	97	50 ksi	65 ksi	9.5	7.25	4	219	689	706	326	689	771	353	689	771
					6.0	6	325	689	857	427	689	857	427	689	857
TRC1411	54	50 ksi	65 ksi	11.5	9.25	4	154	213	269	154	213	269	154	213	269
					8.0	6	178	213	292	178	213	292	178	213	292
	68	50 ksi	65 ksi	11.5	9.25	4	189	338	386	194	338	386	194	338	386
					8.0	6	224	338	419	224	338	419	224	338	419
	97	50 ksi	65 ksi	11.5	9.25	4	189	689	672	277	689	672	277	689	672
					8.0	6	279	689	729	320	689	729	320	689	729
TRC156	54	50 ksi	65 ksi	5.0	3.0	4	298	228	633	443	228	633	594	228	633
					3.0	6	373	228	633	555	228	633	594	228	633
	68	50 ksi	65 ksi	5.0	1.0	9	596	228	1170	887	228	1170	1767	228	1170
					3.0	4	298	363	706	443	363	907	748	363	907
	97	50 ksi	65 ksi	5.0	3.0	6	373	363	907	555	363	907	748	363	907
					1.0	9	596	363	1590	887	363	1679	1800	363	1679
TRC173	54	50 ksi	65 ksi	3.0	1.0	4	612	320	706	912	320	1010	1850	320	1010
					1.0	6	733	320	1060	1091	320	1578	2215	320	1640
	68	50 ksi	65 ksi	3.0	1.0	4	612	508	706	912	507	1050	1850	507	1603
					1.0	6	733	508	1060	1091	508	1578	2215	508	2351
	97	50 ksi	65 ksi	3.0	1.0	4	612	706	706	912	1034	1050	1850	1034	2135
					1.0	6	733	1034	1060	1091	1034	1578	2215	1034	3203

Table Notes:

1. The tabulated clip capacity values are based on the AISI Research Report PR18-4 "Load Bearing Clip Angle Design" phase II and accepted industry design standards.
2. The anchor strength to the support must be calculated separately, the minimum of the tabulated clip capacity and the anchor strength must be used. Anchor strength may be less than the tabulated clip capacity.
3. Appropriate interaction equation must be used for clips subjected to the combined shear tension and compression forces.

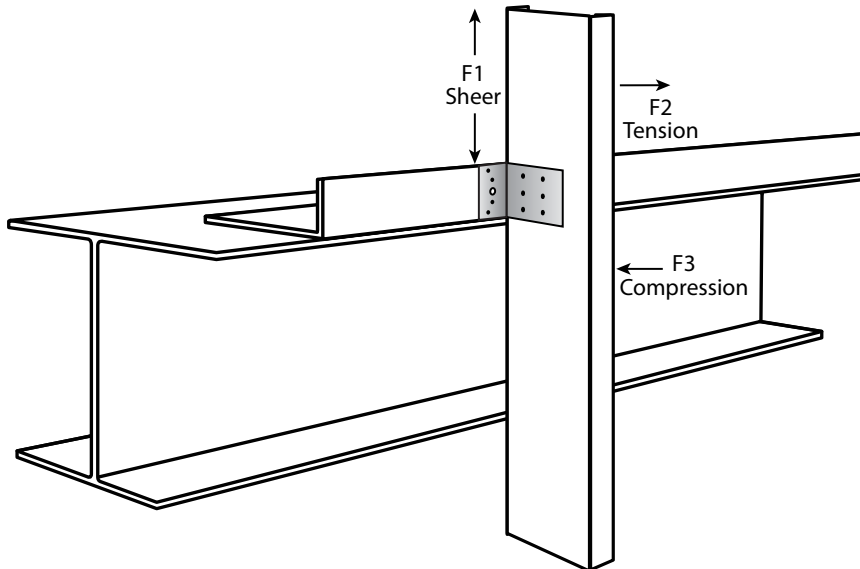

- Clip performance data lists allowable loads in 3 directions as shown.
- ASTM A653 compliant

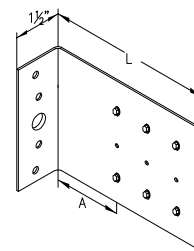

6 SCREW PATTERN

"A" - DIST. TO FIRST ROW OF SCREWS .

THIRD PARTY PE
CALCULATED AND
VALIDATED.



TRC A SERIES - CUSTOM RIGID CLIPS

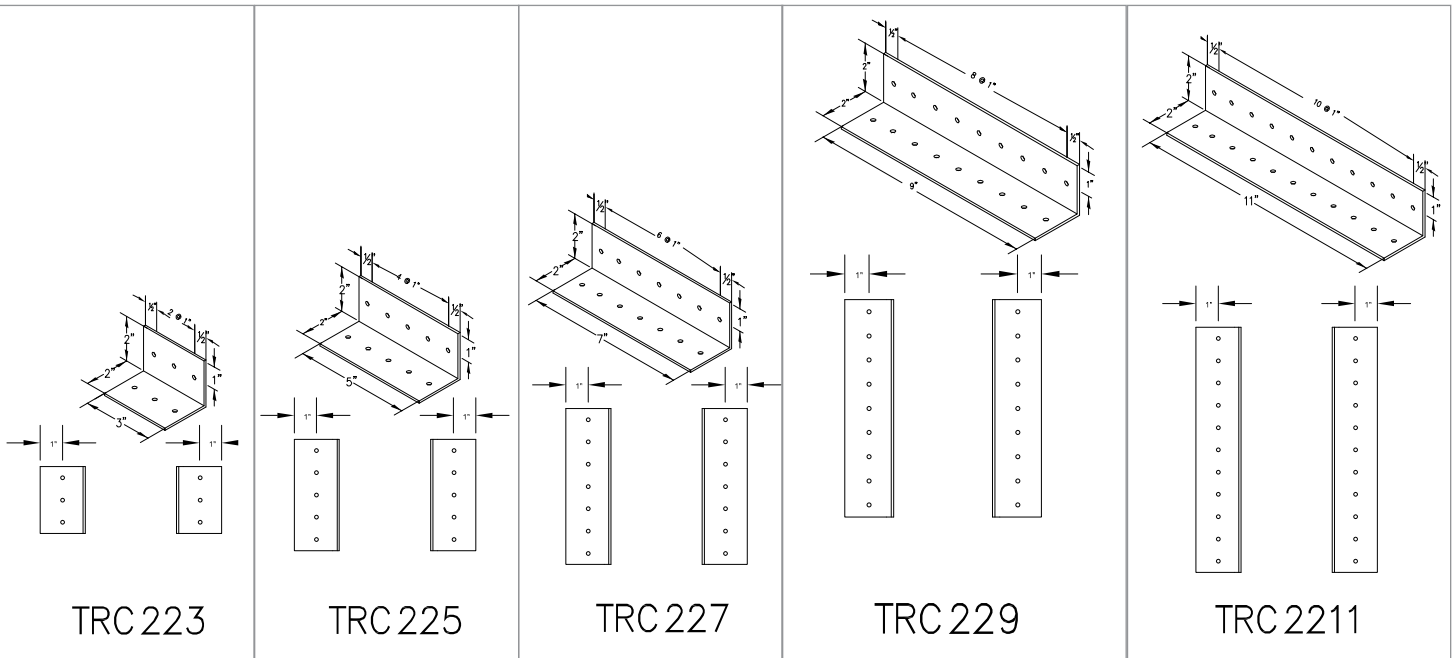
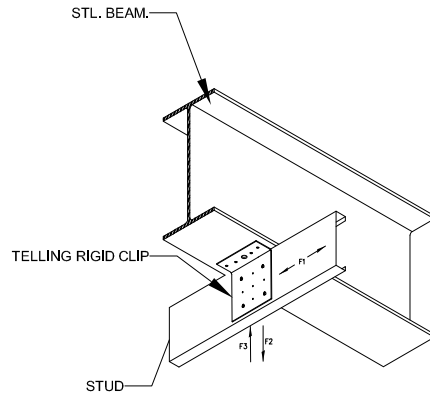
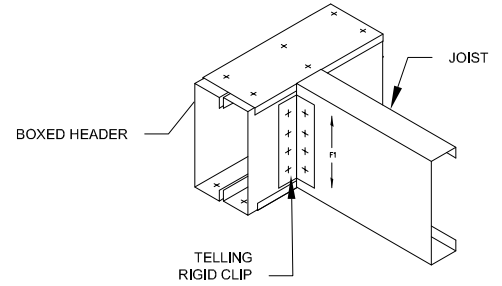
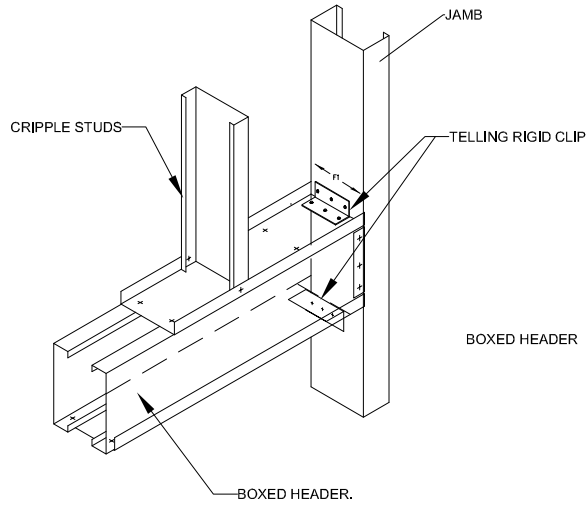
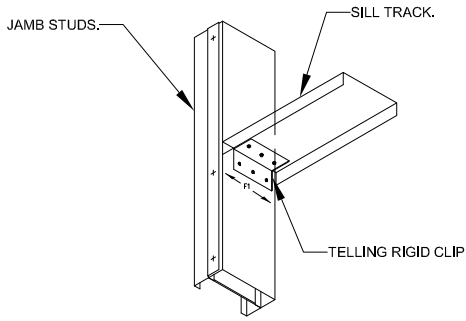

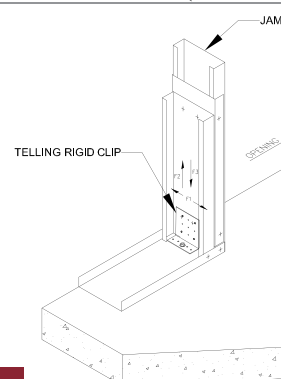
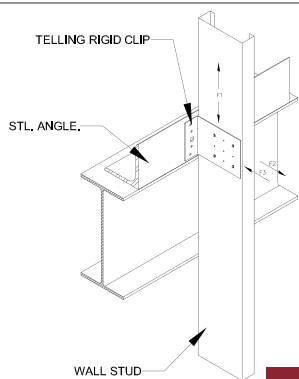
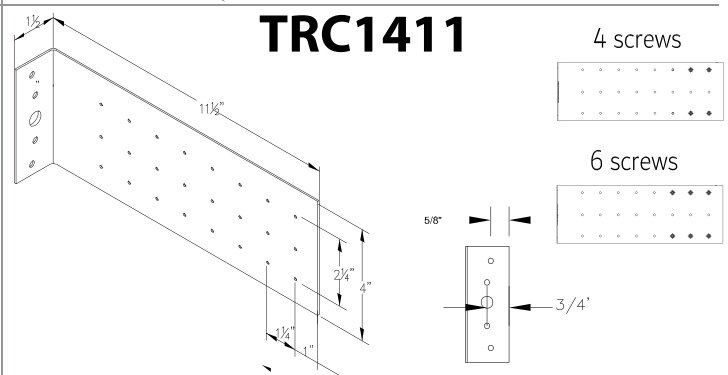
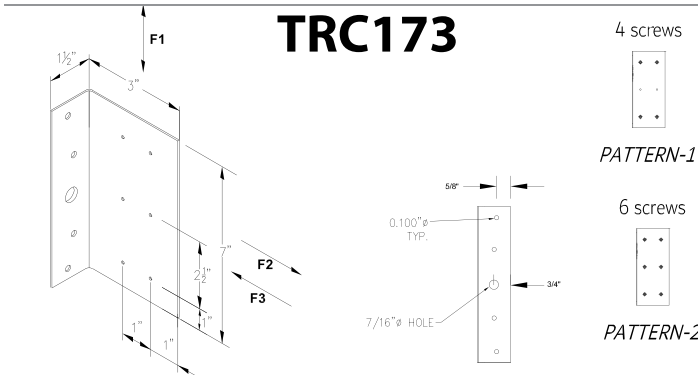
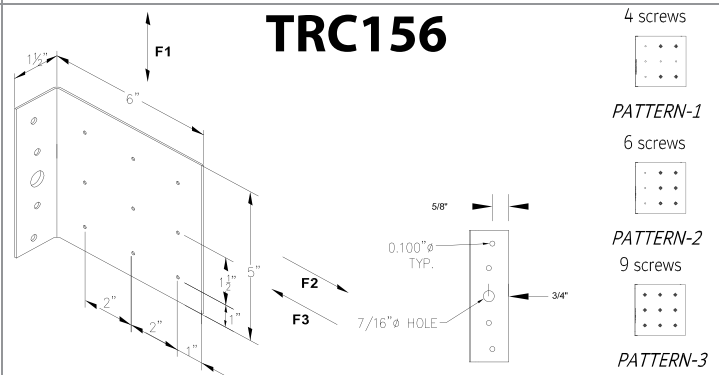
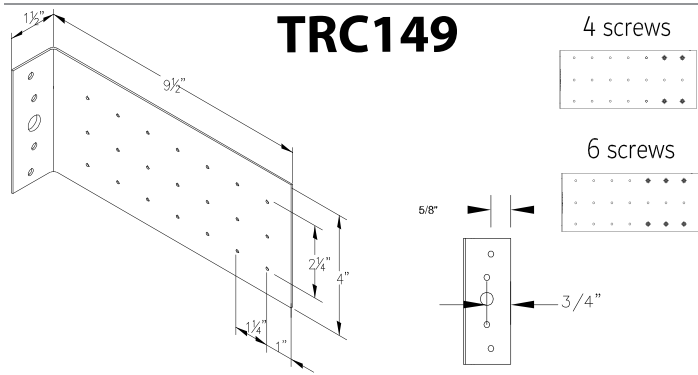
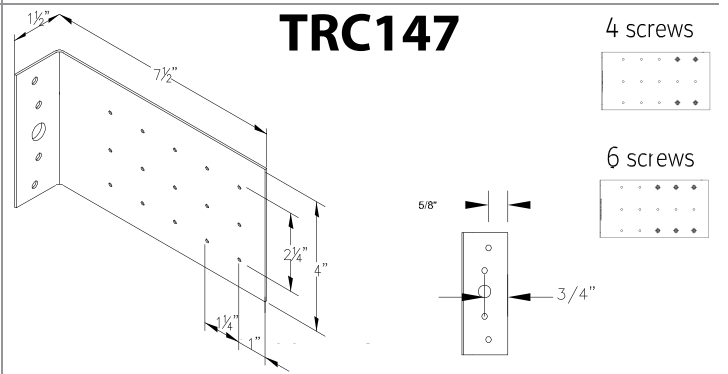
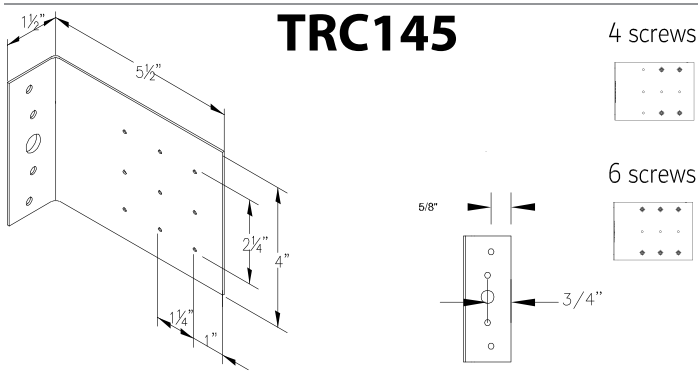
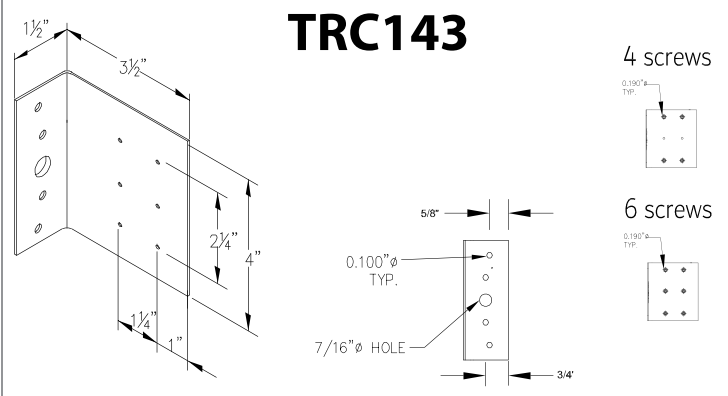
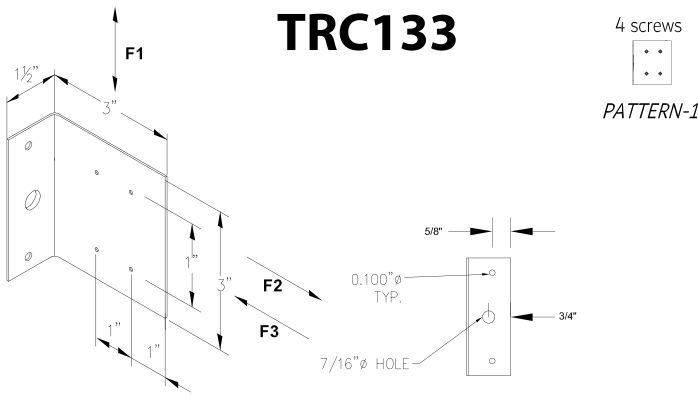

PRODUCT DATA:

- Available in most sizes, lengths, and gauges
- 14ga standard right angle: 1.5" x 1.5" and 2.0" x 2.0"--16ga, 18ga standard right angle, 30mil, 20S 33mil: 1.5" x 1.5", 2.0" x 2.0", 3.0" x 3.0"
- 12ga, and any specialty angles > 3"x3" up to 8"x 8"

USES:

- For miscellaneous attachments of intersection framing components
- For attachment of joist framing components to flush mounted headers
- For attachment of solid blocking sections to adjacent studs of joists
- For alternate screw attachment of CRC briding to stud webs in lieu direct weld
- For 90 degree corner enclosures at lapped framing location; provides in-plane stability of framework

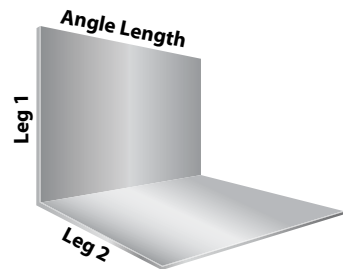

Note: 4 Screws min.

PRE-PUNCHED

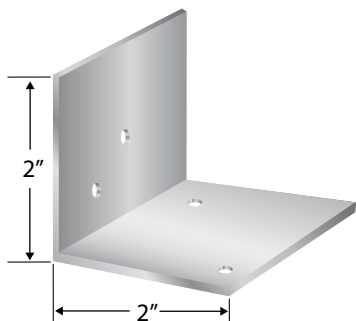
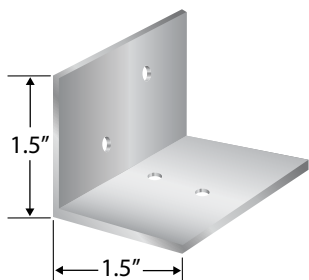

HOLE STANDARD OFFERING:

- Max of 6 hole grouping pattern, next pattern 1" apart.
 - 2 holes can be a max of 3" center line to center line side by side due to the width of the drill head attachment.
 - The 6 holes must be within a 10" length due to the length of the drill head attachment
- Slots: Please inquire
- Hole sizes: (#6, #8, #10, & #12 screw sizes)
 - Min hole size = 7/64" for a #6 screw
 - Must have 1/8" for #8 screw
 - Must have 5/32" hole for #10 screw
 - Must have 3/16" hole for #12 screw
 - Max hole size = 3/8"
- Dimensioned drawing or sketch of hole pattern & locations are required

RIGHT ANGLE/CLIP ANGLE CUSTOM HOLES:

Custom drilled holes are available in the following gauges & sizes for right angles:

- 14ga standard right angle: 1.5" x 1.5" and 2.0" x 2.0"
- 16ga, 18ga standard right angle, 30mil, 20S 33mil: 1.5" x 1.5", 2.0" x 2.0", 3.0" x 3.0"
- 12ga, and any specialty angles > 3"x3" up to 8"x 8"

CUSTOM HOLE PUNCH PATTERNS

Illustration is an example of 1 of 1000's of possible custom hole patterns.

PRODUCT DATA:

- Maximum of 6 holes per pattern grouping
- Leg 1 + Leg 2 = max of 10", min of 1.5"
- Clip Length = max of 17", min of 2.0"

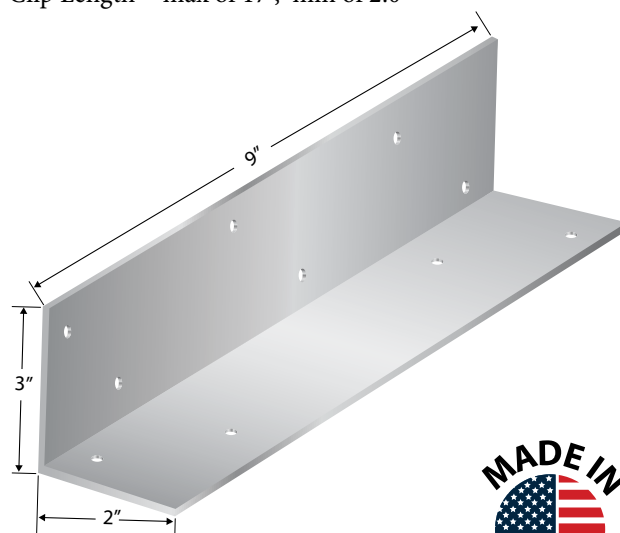
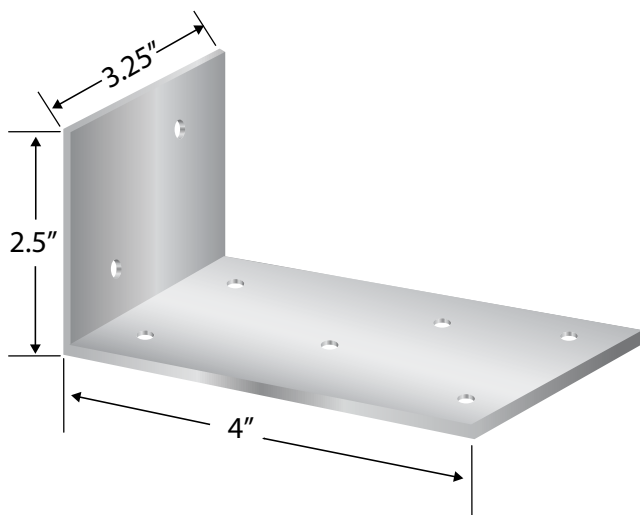



TRUE-BRIDGE CLIPS

US Patent # 10,508,446|10,563,401

True-Bridge Clips are a highly engineered new product from Telling used with True-Brace or traditional CRC mechanical bridging.

Telling's True-Bridge clips were engineered with the installer in mind. The ergonomic design facilitates easy screw drive access and hands free assembly.

The patented True-Bridge Clips are made of 18 gauge, premium steel and are available in two functional designs, terminating and joining.

TYPES OF TRUE-BRIDGE CLIPS:

TRUE-BRIDGE CLIP (TERMINATING)

- Used to join True-Brace to a Stud at a corner, doorway, or end of wall
- 1.75" X 3.2" X 1.25"

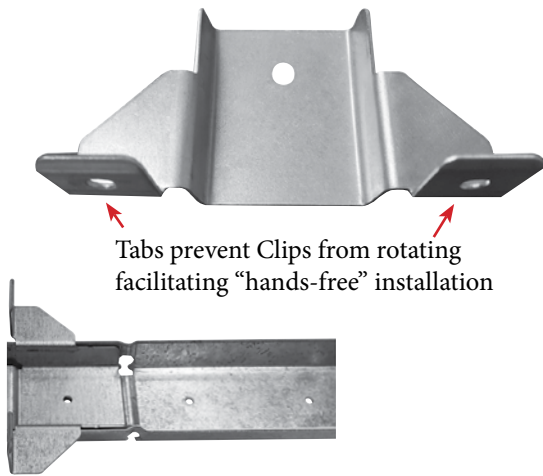

TRUE-BRIDGE CLIP (JOINING)

- Used to joint True-Brace to True-Brace or CRC to CRC for higher load applications
- 3.5" X 3.2" X 1.25"

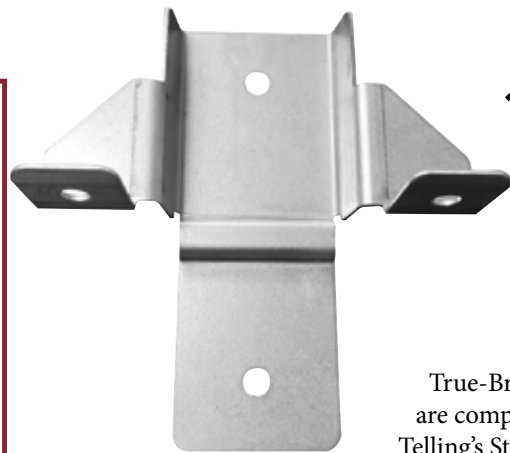

SEE THE VIDEO

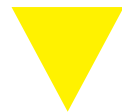

True-Bridge clips are compatible with Telling's Standard CRC Bracing & True-Brace.

FEATURES:

- Made of Galvanized Steel
- Highly Engineered for Ease of Installation
- Slides Easily into Place When Used in Conjunction with True-Brace

BENEFITS:

- Reduces Installation Time
- 10% Savings on Material and Labor Costs
- No Clips or Welding Required
- Easy Installation Due to Patented Design

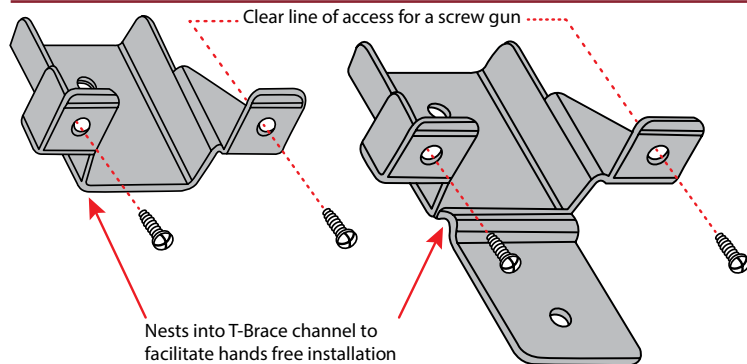

USES:

- Used to join True-Brace to a stud at a corner, doorway, or end of wall
- 1 Screw to True-Brace and up to 2 Screws to Stud
- Clip is also compatible with standard CRC Bracing



Allowable Rotational Loads

CFS Member	Tested Ultimate Moment (in-lbs)	Allowable Load (in-lbs)	Stiffness (in-lbs/radian)
362S162-68	1168	546	4932
362S162-97	1648	770	6972
600S162-68	1261	589	4026
600S162-97	2011	939	7097

Allowable Lateral Loads

CFS Member	Tested Ultimate Load (lbs)	Allowable Load (in-lbs)	Stiffness (lbs/in) at 0.5 Pult
362S162-68	1268	592	1260
362S162-97	1535	717	1998
600S162-68	1312	613	1390
600S162-97	2299	1074	4575

Table Notes:

1. Tested results are the average loads utilizing 16ga True-Brace Bridging with 18ga True-Bridge Clips.
2. The Rotational Stiffness is calculated based on the average test deflection divided by the load.
3. The Lateral Stiffness is calculated based on the average test deflection divided by the load at 50% of the ultimate load.
4. Results are 3rd party PE validated.

T-BACKING CLIP (TBKC) - WALL SUPPORT CLIP

PRODUCT APPLICATION

TBKC products are cost effective and labor saving solution to creating superior backing support for wall shelving, cabinetry, heavy wall hangings, and other equipment.

Installation is simplified by using 2 screws to attach the clip to the stud flange with 2 or 3 screws attached to the wood blocking. Designed to mate with all stud flanges up to 3". Metal tabs support 2" x 6" structure grade lumber (#1 or better) as required by codes or specifications.

FEATURE AND BENEFITS

- Loads based on #8 screws
- Pre-punched guide holes
- Bent tabs for consistent wood positioning

MATERIAL COMPOSITION

- Mill certified steel
- ASTM A653/A653M
- 33 mil
 - 33 ksi yield strength
 - G60 galvanized coating

QUANTITY / ORDER INFORMATION

Part Number	Flange Width	Qty/Bucket	Lbs/Bucket
TBKC-33	1-1/4" to 3"	200	50

ALLOWABLE LOADS

Part Number	Stud Properties			F1 Allowable Loads (Lbs)		F3 Allowable Loads (lbs)	
	Mil	Gauge	Fy (ksi)	2 #8 Screws	3 #8 Screws	2 #8 Screws	3 #8 Screws
TBKC-33	33	20 (S)	33	142	213	321	483

Notes:

1. The allowable loads are based on the steel properties of the members being connected, per AISI S100.
2. Allowable loads indicated on the table(s) are for force in single direction only. The designer shall use the combined forces check as required by AISI S100 if more than one force is applied to the connection.
3. The nominal strength of the screw must be at least 3.75 times the allowable loads.
4. Values include a 3.0 factor of safety.
5. Penetration of screws through joined materials should not be less than three exposed threads. Install and tighten screws in accordance with the screw manufacturer's recommendations.
6. Allowable loads have not been increased for wind, seismic activity, or other factors.

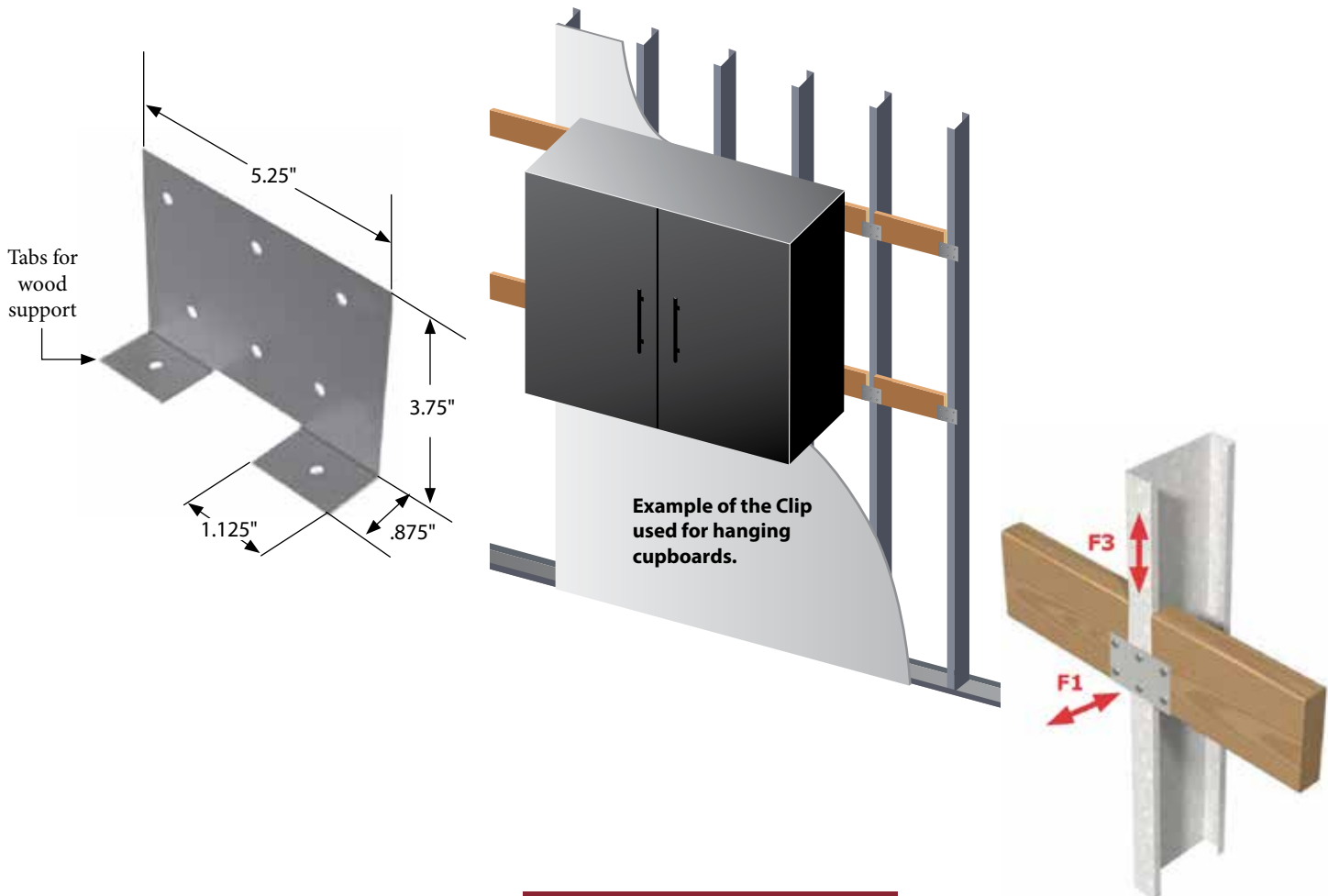

TITAN HEADER CLIPS

TITAN SYSTEM ADVANTAGES:

- No more built-up jambs and headers
- Saves over 50% in installation and material over convention framing
- Substantial reduction in number of screws needed over conventional framing
- Header quickly attaches to jamb with fully tested, pre-drilled Titan Header Clip

WATCH THE
INSTALLATION
VIDEO

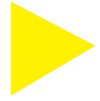

TITAN HEADER CLIP

- **Sizes:** 3-5/8", 6" & 8" x 2-1/4"
- **Thickness:** 68 mils (14ga) 50KSI



MATERIAL SPECIFICATIONS:

ASTM 1003, Grade 50

PRODUCT AVAILABILITY:

Titan Header & Jamb

- **Widths:** 3-5/8", 4", 6", & 8"
- **Flanges:** 2, 2-1/2" & 3"
- **Lip/Return:** 7/8"
- **Thickness:**
 - 54 mils (16ga) 50KSI
 - 68 mils (14ga) 50KSI
 - 97 mils (12ga) 50KSI

TITAN HEADER CLIP

- **Sizes:**
3-5/8", 6" & 8" x 2-1/4"
- **Thickness:**
68 mils (14ga) 50KSI



SLIDE CLIP - VERTICLIP® SL - EXTERIOR HEAD OF WALL

VertiClip® SL connects the exterior curtain wall studs at head of wall to the building frame while allowing for vertical deflection of the structure up to 1½” (¾” up and down). VertiClip’s unique design provides both an anti-friction and anti-seizure connection between the clip and the stud web surface thereby preventing a transfer of vertical forces into curtain wall framing, which is not engineered to support axial loads. Use of VertiClip SL over friction-fit track assemblies helps protect liability through the utilization of positive mechanical attachments to the web of the stud. Allowable loads are based on use of two #12 screws for attachment to stud (provided).

VALUE

- Load-rated positive mechanical attachment at each stud
- Eliminates friction-held assemblies
- Utilizes only certified, 50ksi steel
- Step Bushings pre-installed for accurate placement
- Load rated screws provided for each VertiClip
- Meets all building code criteria
- Adaptable for multiple configurations
- Top of wall bridging or strapping is eliminated
- Top track lightweight for easy handling (not a structural element, may be 20ga standard leg - Deep-Leg Track is not required)
- Utilize clips for wall layout
- Eliminates temporary screws

MATERIAL COMPOSITION

ASTM A1003/A1003M Structural Grade 50 (340) Type H, ST50H (ST340H): 50ksi (340MPa) minimum yield strength, 65ksi (450MPa) minimum tensile strength, 68mil minimum thickness (14 gauge, 0.0713” design thickness) with ASTM A653/A653M G90 (Z275) hot dipped galvanized coating.

The attachment of VertiClip to the primary structure may be made with a PAF, screw/bolt anchors or weld and is dependent upon the base material (steel or concrete) and the design configuration.



PART NUMBER	QTY/BOX	LBS/BOX	QTY/SKID	LBS/SKID
SL362/400	100	37	4,500	1,665
SL600	100	55	4,500	2,475

NOMENCLATURE

VertiClip SL is designated by type (SL), followed by stud depth in inches multiplied by 100

Example: 6” stud

Designate: VertiClip® SL600

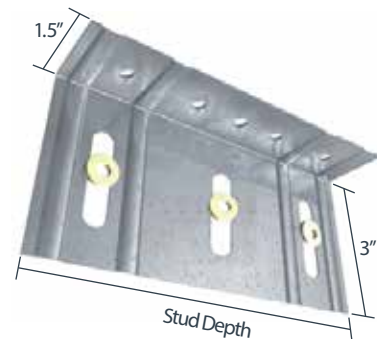

SLIDE CLIP - VERTICLIP® SLD - INTERIOR HEAD OF WALL

VertiClip® SLD connects metal studs at the head condition (top of wall) to the deck or primary frame while allowing for a total vertical deflection of up to 1½” (¾” up and ¾” down). VertiClip’s unique design provides both an anti-friction and anti-seizure connection between the clip and the stud web surface thereby preventing a transfer of vertical forces into drywall partition wall framing, which is not designed to support axial loads.

VALUE

- Load-rated positive mechanical attachment at each stud
- UL classified for all approved dynamic assemblies and finish combinations with 1½” deflection and 1-2 hour fire-ratings
- Meets all building code criteria
- Eliminates loose friction-held track assemblies
- Utilizes only certified, 50ksi steel
- Load rated screws provided for each VertiClip
- Step Bushings pre-installed for accurate placement
- Adaptable for multiple configurations
- Top of wall bridging or strapping is eliminated
- Top track lightweight for easy handling (not a structural element, may be 25ga [interior] or 20ga [exterior] standard leg - Deep-Leg Track is not required)
- Utilize clips for wall layout
- Eliminates temporary screws

MATERIAL COMPOSITION

ASTM A1003/A1003M Structural Grade 50 (340) Type H, ST50H (ST340H): 50ksi (340MPa) minimum yield strength, 65ksi (450MPa) minimum tensile strength, 33mil minimum thickness (20 gauge, 0.0346” design thickness) with ASTM A653/A653M G60 (Z180) hot dipped galvanized coating.

The attachment of VertiClip to the primary structure may be made with a PAF, screw/bolt anchors or weld and is dependent upon the base material (steel or concrete) and the design configuration.



PART NUMBER	QTY/BOX	LBS/BOX	QTY/SKID	LBS/SKID
SLD362/400	200	35	9,000	1,575
SLD600	100	28	4,500	1,260

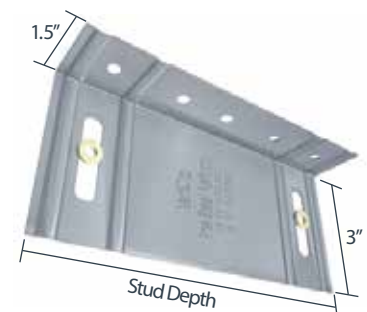

NOMENCLATURE

VertiClip is designated by type (SLD), followed by stud depth in inches multiplied by 100.

Example: 6” stud
Designate: VertiClip® SLD600



Tested per UL2079
WR Grace shaft wall
assembly HW-D-0401.



VertiClip® SLD600
ICC-ESR-2049
www.icc-es.org

SLIDE CLIP - VERTICLIP® SLB - BYPASS SLAB

VertiClip® SLB connects exterior curtain wall studs, bypassing the building structure, while allowing for vertical deflection of the structure up to 2" (1" up and 1" down). VertiClip's unique design provides both an anti-friction and anti-seizure connection between the clip and the stud web surface thereby preventing a transfer of vertical forces into curtain wall framing, which is not engineered to support axial loads. VertiClip SLB eliminates flange-loaded, friction-fit clips, which do not address web-crippling. Three #12 screws for attachment to stud through pre-installed bushings are provided.

VALUE

- Positive, mechanical attachment
- Only certified, 50ksi steel is used
- Step Bushings pre-installed for accurate placement
- Rated screws provided
- Load transferred from stud web
- Elimination of friction-held assemblies
- Meets all building code criteria
- Adaptable for multiple configurations
- Eliminates shims and scabs
- Aligns wall studs quickly and easily by accounting for construction tolerances
- Eliminates bridging or strapping within the bridging spacing from the connection
- Attaches to structure with PAF or welds

MATERIAL COMPOSITION

ASTM A1003/A1003M Structural Grade 50 (340) Type H, ST50H (ST340H): 50ksi (340MPa) minimum yield strength, 65ksi (450MPa) minimum tensile strength, 68mil minimum thickness (14 gauge, 0.0713" design thickness) with ASTM A653/A653M G90 (Z275) hot dipped galvanized coating.

The attachment of VertiClip to the primary structure may be made with a PAF, screw/bolt anchors or weld and is dependent upon the base material (steel or concrete) and the design configuration.

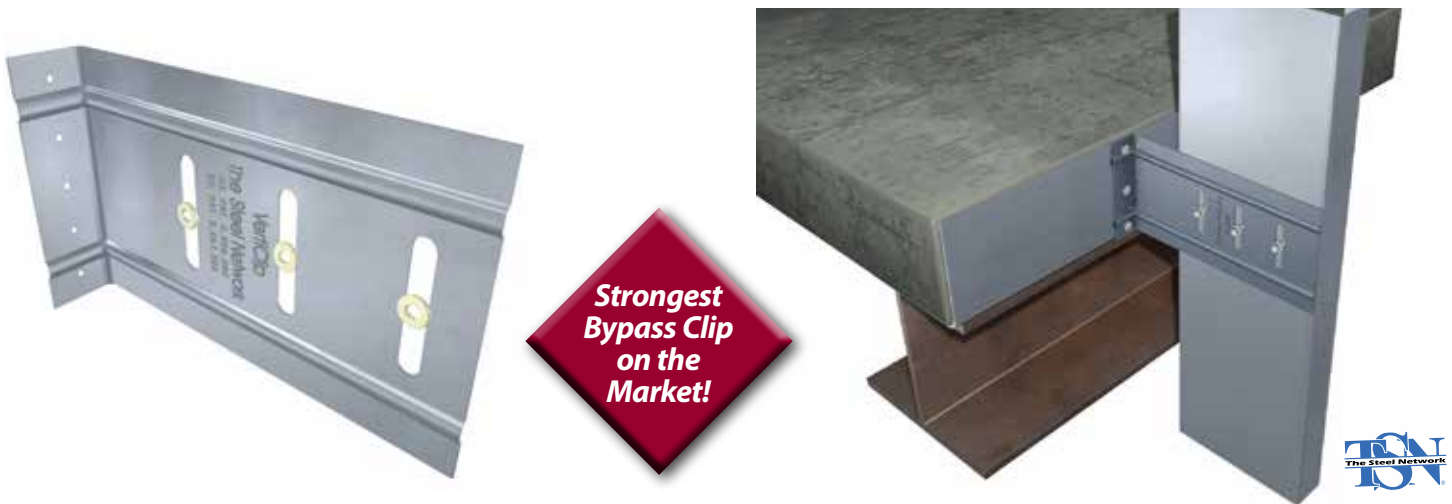

PART NUMBER	QTY/BOX	LBS/BOX	QTY/SKID	LBS/SKID
SLB600	50	38	2,250	1,710
SLB800	50	50	1,600	1,600

NOMENCLATURE

VertiClip SLB is designated by type (SLB), followed by stud depth in inches multiplied by 100.

Example: 6" stud

Designate: VertiClip® SLB600

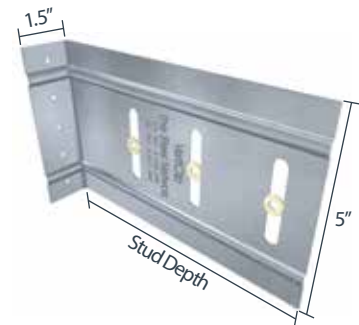

VertiClip® SLB600
ICC-ESR-2049
www.icc-es.org

SLIDE CLIP - VERTICLIP® SLS - STRUCTURE

The VertiClip® SLS slide clip connects exterior curtain wall studs, bypassing the building's structural frame, while allowing for a vertical deflection of the structure up to 1½" (¾" up and ¾" down). VertiClip's unique design provides both an anti-friction and anti-seizure connection between the clip and the stud web surface thereby preventing a transfer of vertical forces into curtain wall framing, which is not engineered to support axial loads. Allowable loads are based on use of two #12 screws for attachment to stud (provided).

VALUE

- Provides a positive, load-rated, mechanical attachment to web of stud
- Eliminates friction-based assemblies
- Utilizes only certified, 50ksi steel
- Eliminates untested "scabs" or shims
- Load rated screws provided
- Step Bushings pre-installed for accurate placement
- Meets all building code criteria
- Adaptable for multiple configurations
- Align wall studs quickly and easily by accounting for construction tolerances
- Lightweight assembly
- Eliminates bridging or strapping within the bridging spacing from the connection

MATERIAL COMPOSITION

ASTM A1003/A1003M Structural Grade 50 (340) Type H, ST50H (ST340H): 50ksi (340 MPa) minimum yield strength, 65ksi (450 MPa) minimum tensile strength, 68mil minimum thickness (14 gauge, 0.0713" design thickness) with ASTM A653/A653M G90 (Z275) hot dipped galvanized coating.

The attachment of VertiClip to the primary structure may be made with PAFs, screw/bolt anchors or weld and is dependent upon the base material (steel or concrete) and the design configuration.



PART NUMBER	QTY/BOX	LBS/BOX	QTY/SKID	LBS/SKID
SLS600-12	50	60	2,250	2,700

NOMENCLATURE

VertiClip SLS is designated by stud depth and clip length required. Clip length includes a minimum of 3" for steel (5.5" for concrete) of clip material for attachment to structure added to stud depth, plus the distance of the stud from the structure.

Example: 6" stud, 3" tolerance, 3" to structure
Designate: VertiClip® SLS600-12



VertiClip® SLS600-12
ICC-ESR-2049
www.icc-es.org

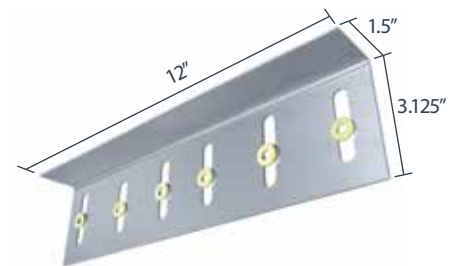

KNEE WALL SUPPORT BRACKET

An engineered system comprised of a 1/2" steel base plate welded to a 14ga structural stud

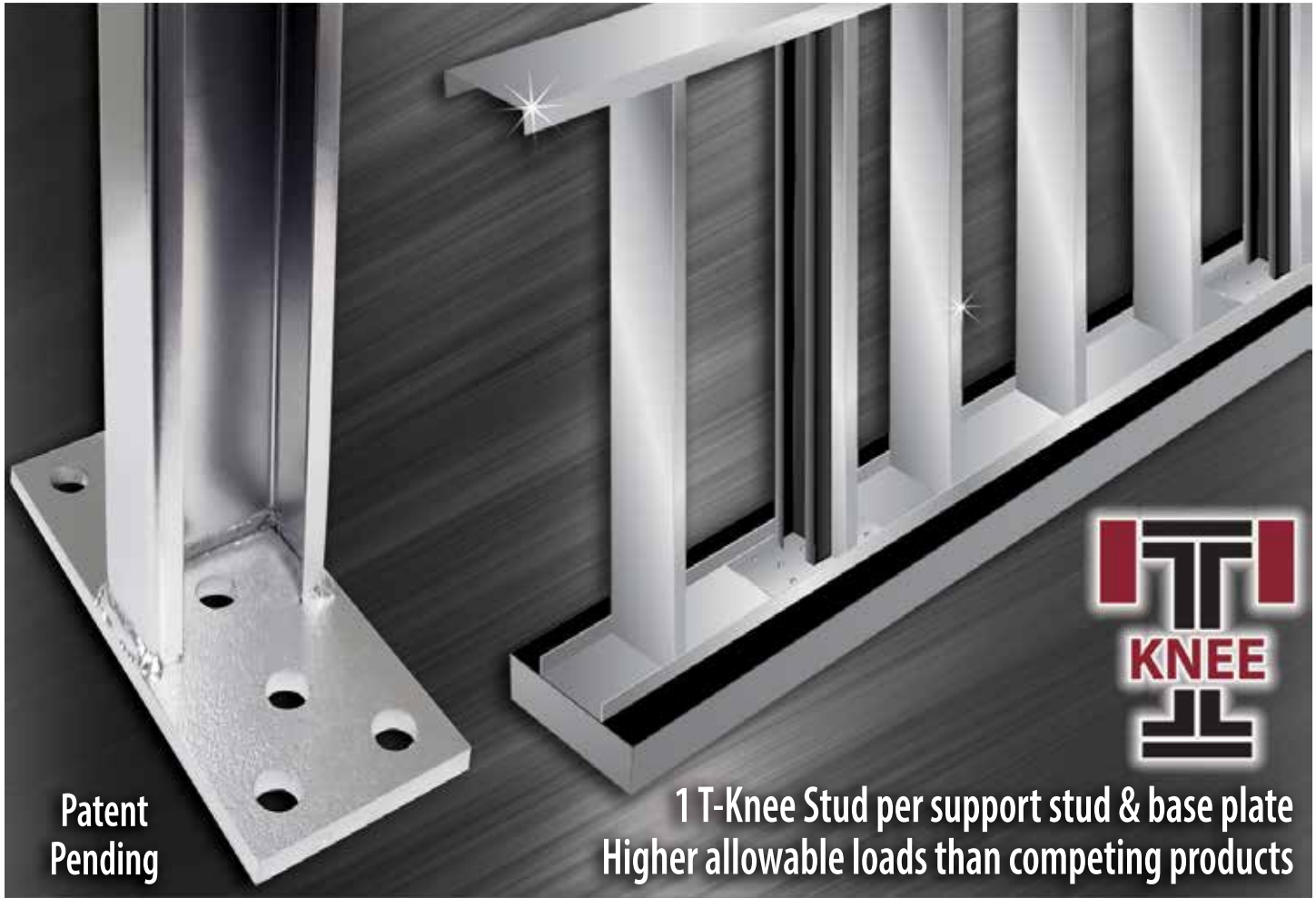

Patent Pending

1 T-Knee Stud per support stud & base plate
Higher allowable loads than competing products



**THE LEADER
IN METAL
FRAMING
INNOVATION**

BUILDSTRONG.com



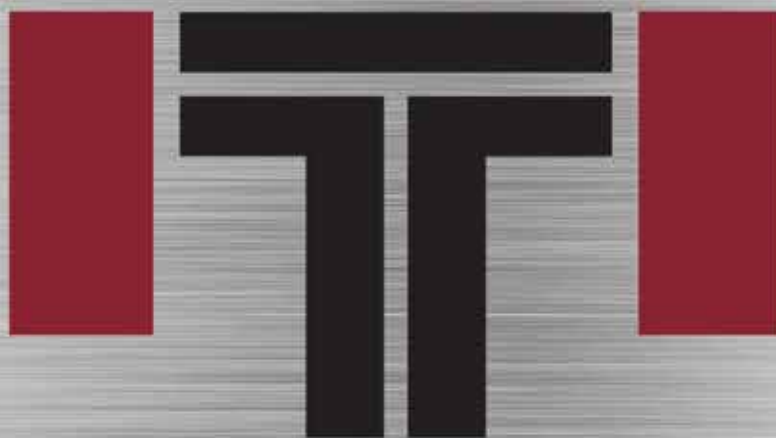

TELLING



MIDWEST FACILITY

2105 Larrick Road
Cambridge, OH 43725

Phone:

740-435-8900

Toll Free:

866-35STUDS (357-8837)

Fax:

740-435-8915

E-mail:

sales.oh@tellingindustries.com

CORPORATE HEADQUARTERS

4420 Sherwin Road
Willoughby, OH 44094

Phone:

440-974-3370

Toll Free:

866-FRAME-TI(372-6384)

Fax:

440-974-3408

E-mail:

sales.corp@tellingindustries.com

MIDSOUTH FACILITY

1400 Southwire Drive
Osceola, AR 72370

Phone:

870-563-6065

Toll Free:

888-711-3124

Fax:

870-563-2471

E-mail:

sales.ar@tellingindustries.com

NORTHEAST FACILITY

1050 Kennedy Road
Windsor, CT 06095

Toll Free:

866-372-6384

Fax:

440-974-3408

E-mail:

sales.corp@tellingindustries.com

**Telling Partners With Multiple
3rd Party Engineering Firms
To Offer Independent
Industry Expert Design & Service.**

RAZ TECH, INC:

(Preferred engineering firm)

Web: www.raztechinc.com

Email: rzadeh@raztechinc.com

Phone: 404-665-7506

SOUTHERN FACILITY

1200 W Dr Martin Luther King Jr Blvd.
Plant City, FL 33563

Toll Free:

866-372-6384

Fax:

440-974-3408

E-mail:

sales.corp@tellingindustries.com